

# **WATO EX-35Vet Anesthesia Machine**

## **Operator's Manual**





© 2019 Shenzhen Mindray Bio-Medical Electronics Co., Ltd. All rights Reserved.  
For this Operator's Manual, the issue date is August, 2019.

---

# Intellectual Property Statement

SHENZHEN MINDRAY BIO-MEDICAL ELECTRONICS CO., LTD. (hereinafter called Mindray) owns the intellectual property rights to this Mindray product and this manual. This manual may refer to information protected by copyright or patents and does not convey any license under the patent rights or copyright of Mindray, or of others.

Mindray intends to maintain the contents of this manual as confidential information. Disclosure of the information in this manual in any manner whatsoever without the written permission of Mindray is strictly forbidden. Release, amendment, reproduction, distribution, rental, adaptation, translation or any other derivative work of this manual in any manner whatsoever without the written permission of Mindray is strictly forbidden.

**mindray**, , **MINDRAY** and **WATO** are the trademarks, registered or otherwise, of Mindray in China and other countries. All other trademarks that appear in this manual are used only for informational or editorial purposes. They are the property of their respective owners.



---

# Responsibility on the Manufacturer Party

Contents of this manual are subject to change without prior notice.

All information contained in this manual is believed to be correct. Mindray shall not be liable for errors contained herein or for incidental or consequential damages in connection with the furnishing, performance, or use of this manual.

Mindray is responsible for the effects on safety, reliability and performance of this product, only if:

- all installation operations, expansions, changes, modifications and repairs of this product are conducted by Mindray authorized personnel;
- the electrical installation of the relevant room complies with the applicable national and local requirements;and
- the product is used in accordance with the instructions for use.

---

## **WARNING**

- **It is important for the hospital or organization that employs this equipment to carry out a reasonable service/maintenance plan. Neglect of this may result in machine breakdown or personal injury.**
- 

## **NOTE**

- **This equipment must be operated by skilled/trained clinical professionals.**
-

---

# Warranty

THIS WARRANTY IS EXCLUSIVE AND IS IN LIEU OF ALL OTHER WARRANTIES, EXPRESSED OR IMPLIED, INCLUDING WARRANTIES OF MERCHANTABILITY OR FITNESS FOR ANY PARTICULAR PURPOSE.

## Exemptions

Mindray's obligation or liability under this warranty does not include any transportation or other charges or liability for direct, indirect or consequential damages or delay resulting from the improper use or application of the product or the use of parts or accessories not approved by Mindray or repairs by people other than Mindray authorized personnel.

This warranty shall not extend to:

- Malfunction or damage caused by improper use or man-made failure.
- Malfunction or damage caused by unstable or out-of-range power input.
- Malfunction or damage caused by force majeure such as fire and earthquake.
- Malfunction or damage caused by improper operation or repair by unqualified or unauthorized service people.
- Malfunction of the instrument or part whose serial number is not legible enough.
- Others not caused by instrument or part itself.

---

# Customer Service Department

Manufacturer: Shenzhen Mindray Bio-Medical Electronics Co., Ltd.  
Address: Mindray Building, Keji 12th Road South, High-tech industrial park, Nanshan, Shenzhen 518057, P.R.China  
Website: [www.mindray.com](http://www.mindray.com)  
E-mail Address: [service@mindray.com](mailto:service@mindray.com)  
Tel: +86 755 81888998  
Fax: +86 755 26582680

EC-Representative: Shanghai International Holding Corp. GmbH (Europe)  
Address: Eiffestraße 80, 20537 Hamburg, GERMANY  
Tel: 0049-40-2513175  
Fax: 0049-40-255726

---

# Preface

## Manual Purpose

This manual contains the instructions necessary to operate the product safely and in accordance with its function and intended use. Observance of this manual is a prerequisite for proper product performance and correct operation and ensures animal and operator safety.

This manual is based on the maximum configuration and therefore some contents may not apply to your product. If you have any question, please contact us.

This manual is an integral part of the product. It should always be kept close to the equipment so that it can be obtained conveniently when needed.

## Intended Audience

This manual is geared for clinical professionals or veterinarian who are expected to have a working knowledge of medical procedures, practices and terminology as required for monitoring of critically ill animals.

## Illustrations

All illustrations in this manual serve as examples only. They may not necessarily reflect the setup or data displayed on your anesthesia machine.

## Conventions

- *Italic* text is used in this manual to quote the referenced chapters or sections.
- [ ] is used to enclose screen texts.
- → is used to indicate operational procedures.

## Password

A password is required to access different modes within the anesthesia machine.

- Manage Configuration: 1234

# Contents

<b>1 Safety</b> .....	<b>1-1</b>
1.1 Safety Information .....	1-1
1.1.1 Dangers .....	1-2
1.1.2 Warnings.....	1-2
1.1.3 Cautions .....	1-7
1.1.4 Notes .....	1-9
1.2 Equipment Symbols .....	1-11
<b>2 The Basics</b> .....	<b>2-1</b>
2.1 System Description .....	2-1
2.1.1 Intended Use.....	2-1
2.1.2 Contraindications .....	2-1
2.1.3 Components .....	2-2
2.2 Equipment Appearance .....	2-3
2.2.1 Front View.....	2-3
2.2.2 Rear View.....	2-9
2.2.3 Pendant-mounted Anesthesia Machine .....	2-15
2.3 Batteries .....	2-16
<b>3 System Controls and Basic Settings</b> .....	<b>3-1</b>
3.1 Display Screen .....	3-1
3.1.1 Waveform Tab .....	3-3
3.1.2 Spirometry Tab.....	3-4
3.1.3 Ventilation Mode Tab .....	3-5
3.1.4 Measured Values Area.....	3-5
3.1.5 Elapsed Timer.....	3-5
3.1.6 Date and Time .....	3-6
3.2 Display Control .....	3-7
3.2.1 Standby Key .....	3-8
3.2.2 Menu Key.....	3-8
3.2.3 Alarm Key.....	3-19
3.2.4 Audio Pause Key .....	3-19
<b>4 Operations and Ventilation Setup</b> .....	<b>4-1</b>
4.1 Turn on the System .....	4-1
4.2 Turn off the System.....	4-3
4.3 Animal Setup.....	4-3
4.3.1 Enter Standby Mode.....	4-3
4.3.2 Exit Standby Mode.....	4-4
4.4 Input Fresh Gas .....	4-5
4.4.1 Set O <sub>2</sub> , N <sub>2</sub> O and Air Inputs .....	4-5

---

4.4.2 Set Anesthetic Agent .....	4-6
4.5 Set Ventilation Mode .....	4-7
4.5.1 Monitored Parameters .....	4-7
4.5.2 Set Manual Ventilation Mode .....	4-8
4.5.3 Settings before Starting Mechanical Ventilation Mode .....	4-9
4.5.4 Volume Control Ventilation (VCV) .....	4-10
4.5.5 Pressure Control Ventilation .....	4-13
4.5.6 Synchronized Intermittent Mandatory Ventilation (SIMV) .....	4-15
4.5.7 Pressure Support Ventilation .....	4-19
4.5.8 Auxiliary Common Gas Outlet (ACGO) .....	4-22
4.5.9 Monitor .....	4-22
4.5.10 Bypass .....	4-23
4.6 Start Mechanical Ventilation .....	4-23
4.7 Stop Mechanical Ventilation .....	4-24
<b>5 Parameter Monitoring .....</b>	<b>5-1</b>
5.1 General Description .....	5-1
5.2 Pressure Monitoring .....	5-1
5.2.1 Display Pressure Parameters .....	5-1
5.2.2 Display Paw Waveform .....	5-2
5.2.3 Auto-zero the Pressure Sensors .....	5-2
5.3 Volume Monitoring .....	5-3
5.3.1 Display Volume Parameters .....	5-3
5.3.2 Display Volume Waveform .....	5-3
5.4 CO <sub>2</sub> Concentration Monitoring .....	5-3
5.4.1 Display Gas Parameter .....	5-4
5.4.2 Display Gas Waveform .....	5-4
5.5 Waveform Autoscaling .....	5-5
5.6 Inspired O <sub>2</sub> (FiO <sub>2</sub> ) .....	5-6
5.7 Spirometry .....	5-6
<b>6 Preoperative Test .....</b>	<b>6-1</b>
6.1 Preoperative Test Schedules .....	6-1
6.2 Inspect the System .....	6-2
6.3 System Self- Test .....	6-3
6.4 Leak and Compliance Tests .....	6-4
6.4.1 Automatic Circuit Leak and Compliance Test .....	6-4
6.4.2 Manual Circuit Leak Test .....	6-5
6.5 Power Failure Alarm Test .....	6-6
6.6 Pipeline Tests .....	6-6
6.6.1 O <sub>2</sub> Pipeline Test .....	6-7
6.6.2 N <sub>2</sub> O Pipeline Test .....	6-7
6.6.3 Air Pipeline Test .....	6-8
6.7 Basic Ventilation Test .....	6-8

---

---

6.8 Cylinder Tests.....	6-9
6.8.1 Check the Cylinder Pressure .....	6-9
6.8.2 O <sub>2</sub> Cylinder High Pressure Leak Test.....	6-9
6.8.3 N <sub>2</sub> O Cylinder High Pressure Leak Test.....	6-9
6.8.4 Air Cylinder High Pressure Leak Test.....	6-10
6.9 Backup Oxygen Supply Tests.....	6-10
6.10 Flow Control System Tests .....	6-11
6.10.1 Without O <sub>2</sub> Concentration Monitoring .....	6-11
6.10.2 With O <sub>2</sub> Concentration Monitoring .....	6-13
6.11 Vaporizer Test.....	6-14
6.11.1 Vaporizer Back Pressure Test .....	6-14
6.11.2 Vaporizer Leak Test.....	6-15
6.12 Breathing System Tests .....	6-16
6.12.1 Bellows Test .....	6-16
6.12.2 APL Valve Test.....	6-17
6.13 Alarm Tests.....	6-18
6.13.1 Prepare for Alarm Tests .....	6-18
6.13.2 Test the O <sub>2</sub> Concentration Monitoring and Alarms .....	6-19
6.13.3 Test the Low Minute Volume (MV) Alarm .....	6-20
6.13.4 Test the Apnea Alarm .....	6-20
6.13.5 Test the Continuous Airway Pressure Alarm.....	6-21
6.13.6 Test the High Paw Alarm.....	6-21
6.13.7 Test the Low Paw Alarm .....	6-21
6.13.8 Test the CO <sub>2</sub> Module Alarm .....	6-22
6.13.9 Test the AG Module Alarm .....	6-22
6.14 Preoperative Preparations.....	6-22
6.15 Inspect the AGSS .....	6-23
6.16 Inspect the Negative Pressure Suction Device .....	6-24
<b>7 User Maintenance.....</b>	<b>7-1</b>
7.1 Maintenance Schedule .....	7-1
7.2 Breathing System Maintenance.....	7-2
7.3 Flow Sensor Calibration.....	7-3
7.4 O <sub>2</sub> Sensor Calibration.....	7-5
7.4.1 Calibrate the O <sub>2</sub> Sensor .....	7-6
7.4.2 Troubleshooting Information.....	7-8
7.5 Water Build-up in the Flow Sensor .....	7-9
7.5.1 Prevent Water Build-up .....	7-9
7.5.2 Clear Water Build-up.....	7-9
7.6 AGSS Transfer Tube Maintenance.....	7-10
7.7 Electrical Safety Inspection.....	7-10
7.7.1 Auxiliary Electrical Outlet Test.....	7-10
7.7.2 Electrical Safety Inspection Test .....	7-10

---

---

<b>8 CO<sub>2</sub> Monitoring</b> .....	<b>8-1</b>
8.1 Introduction.....	8-1
8.2 Identify CO <sub>2</sub> Module.....	8-2
8.3 Use a Sidestream CO <sub>2</sub> Module.....	8-3
8.3.1 Prepare to Measure CO <sub>2</sub> .....	8-4
8.3.2 Make CO <sub>2</sub> Settings.....	8-5
8.3.3 Measurement Limitations.....	8-7
8.3.4 Troubleshooting.....	8-8
8.3.5 Scavenge the Sample Gas.....	8-8
8.3.6 Zero the Sensor.....	8-9
8.3.7 Calibrate the Sensor.....	8-9
8.4 Use a Microstream CO <sub>2</sub> Module.....	8-9
8.4.1 Prepare to Measure CO <sub>2</sub> .....	8-10
8.4.2 Make CO <sub>2</sub> Settings.....	8-10
8.4.3 Measurement Limitations.....	8-12
8.4.4 Scavenge the Sample Gas.....	8-13
8.4.5 Zero the Sensor.....	8-13
8.4.6 Calibrate the Sensor.....	8-14
8.4.7 Oridion Information.....	8-14
8.5 Use a Mainstream CO <sub>2</sub> Module.....	8-15
8.5.1 Prepare to Measure CO <sub>2</sub> .....	8-15
8.5.2 Make CO <sub>2</sub> Settings.....	8-16
8.5.3 Measurement Limitations.....	8-18
8.5.4 Zero the Sensor.....	8-19
8.5.5 Calibrate the Sensor.....	8-19
<b>9 AG and O<sub>2</sub> Concentration Monitoring</b> .....	<b>9-1</b>
9.1 Introduction.....	9-1
9.2 Identify AG Modules.....	9-2
9.3 Prepare to Measure AG.....	9-2
9.4 Make AG Settings.....	9-4
9.4.1 Set Flow Rate.....	9-4
9.4.2 Set Operating Mode.....	9-5
9.4.3 Set CO <sub>2</sub> Unit.....	9-5
9.4.4 Gas Scale.....	9-5
9.4.5 CO <sub>2</sub> Placement.....	9-6
9.5 Change Anesthetic Agent.....	9-6
9.6 Measurement Limitations.....	9-6
9.7 Troubleshooting.....	9-7
9.8 Scavenge the Sample Gas.....	9-7
9.9 Calibrate the AG Module.....	9-8
<b>10 Alarms</b> .....	<b>10-1</b>
10.1 Introduction.....	10-1

---



---

10.1.1	Types of Alarms and Messages .....	10-1
10.1.2	Alarm Indicators .....	10-2
10.2	Display Alarms .....	10-3
10.3	Displayed Order of Alarm Messages .....	10-4
10.4	Set Alarm Volume .....	10-4
10.5	Set Alarm Limits .....	10-5
10.5.1	Set Ventilator Alarm Limits.....	10-6
10.5.2	Set CO <sub>2</sub> Alarm Limits .....	10-6
10.5.3	Set AG Alarm Limits.....	10-6
10.5.4	Auto Alarm Limits.....	10-7
10.6	Alarm Audio Pause.....	10-8
10.6.1	Set Alarm Audio Pause.....	10-8
10.6.2	Cancel Alarm Audio Pause.....	10-8
10.7	When an Alarm Occurs .....	10-9
<b>11</b>	<b>Installations and Connections .....</b>	<b>11-1</b>
11.1	Install the Breathing System.....	11-1
11.1.1	Breathing System Compatible with Pre-Pak .....	11-2
11.1.2	Breathing System Not Compatible with Pre-Pak .....	11-20
11.2	Install the Vaporizer.....	11-38
11.2.1	Assemble the Vaporizer .....	11-38
11.2.2	Fill the Vaporizer .....	11-41
11.2.3	Drain the Vaporizer .....	11-45
11.3	Replace the Gas Cylinder .....	11-48
11.4	Install the Modules .....	11-50
11.4.1	Install the CO <sub>2</sub> Module.....	11-50
11.4.2	Install the AG Module .....	11-50
11.5	Pneumatic Connections .....	11-51
11.5.1	Connect the Pipeline Gas Supplies.....	11-52
11.5.2	Connect the Cylinder Gas Supply .....	11-52
11.5.3	Connect the Backup Oxygen Supply.....	11-53
11.6	Sample Gas Return Port and AGSS Outlet.....	11-53
11.7	AGSS Transfer and Receiving System .....	11-54
11.7.1	Components.....	11-54
11.7.2	Assemble the AGSS.....	11-55
11.7.3	Waste Gas Disposal System .....	11-57
11.8	Negative Pressure Suction Device .....	11-58
11.8.1	Structure and Components .....	11-58
11.8.2	Install the Negative Pressure Suction Device.....	11-59
11.8.3	Turn on/off the Negative Pressure Suction Device.....	11-61
<b>12</b>	<b>Cleaning and Disinfection.....</b>	<b>12-1</b>
12.1	Clean and Disinfect the Anesthesia Machine Housing.....	12-2
12.2	Disassemble the Breathing System Cleanable Parts .....	12-3

---

---

12.2.1 Breathing System Compatible with Pre-Pak .....	12-3
12.2.2 Breathing System Not Compatible with Pre-Pak .....	12-15
12.3 Clean & Disinfect and Re-install the Breathing System .....	12-31
12.3.1 Breathing System .....	12-33
12.3.2 Water Collection Cup .....	12-34
12.3.3 Inspiratory and Expiratory Check Valves Assembly .....	12-34
12.3.4 Flow Sensor.....	12-34
12.3.5 Bellows Assembly .....	12-35
12.3.6 Airway Pressure Gauge .....	12-36
12.3.7 Bag Arm .....	12-36
12.3.8 Breathing Tubes and Y-Piece .....	12-37
12.3.9 Manual Bag .....	12-37
12.3.10 O <sub>2</sub> Sensor.....	12-37
12.3.11 CO <sub>2</sub> Absorbent Canister .....	12-38
12.3.12 Breathing Mask .....	12-38
12.4 AGSS Transfer and Receiving System.....	12-38
12.5 Negative Pressure Suction Device .....	12-40
<b>13 Accessories .....</b>	<b>13-1</b>
<b>A Theory of Operation.....</b>	<b>A-1</b>
A.1 Pneumatic Circuit System .....	A-1
A.2 Electrical System Structure .....	A-7
<b>B Product Specifications.....</b>	<b>B-1</b>
B.1 Safety Specifications .....	B-2
B.2 Environmental Specifications.....	B-2
B.3 Power Requirements.....	B-3
B.4 Physical Specifications .....	B-4
B.5 Pneumatic Circuit System Specifications.....	B-6
B.6 Breathing System Specifications .....	B-7
B.7 Ventilator Specifications.....	B-9
B.8 Ventilator Accuracy .....	B-11
B.9 Anesthetic Vaporizer.....	B-13
B.10 Breathing System Temperature Controller .....	B-13
B.11 AGSS Transfer and Receiving System Specifications.....	B-14
B.12 Negative Pressure Suction Device Specifications .....	B-14
B.13 O <sub>2</sub> Sensor Specifications .....	B-15
B.14 CO <sub>2</sub> Module Specifications .....	B-18
B.15 AG Module Specifications .....	B-21
<b>C EMC .....</b>	<b>C-1</b>
<b>D Alarm and Prompt Messages.....</b>	<b>D-1</b>

---

---

D.1 Physiological Alarm Messages.....	D-1
D.2 Technical Alarm Messages .....	D-4
D.3 Prompt Messages .....	D-14
<b>E Symbols and Abbreviations .....</b>	<b>E-1</b>
E.1 Symbols .....	E-1
E.2 Units of Measure.....	E-1
E.3 Abbreviations.....	E-3
<b>F Factory Defaults.....</b>	<b>F-1</b>
F.1 Main Screen .....	F-1
F.2 Alarm Menu .....	F-1
F.3 Main Menu .....	F-3
F.4 Date/Time .....	F-6
F.5 Ventilation Modes .....	F-6
F.6 Ventilation Parameter Relationships.....	F-10

---

**FOR YOUR NOTES**

# 1 Safety

---

---

## 1.1 Safety Information

---

---

### DANGER

---

- Indicates an imminent hazard that, if not avoided, will result in death or serious injury.
- 
- 

### WARNING

---

- Indicates a potential hazard or unsafe practice that, if not avoided, could result in death or serious injury.
- 
- 

### CAUTION

---

- Indicates a potential hazard or unsafe practice that, if not avoided, could result in minor personal injury or product/property damage.
- 
- 

### NOTE

---

- Provides application tips or other useful information to ensure that you get the most from your product.
- 
-

---

## 1.1.1 Dangers

There are no dangers that refer to the product in general. Specific “Danger” statements may be given in the respective sections of this manual.

## 1.1.2 Warnings

---

### **WARNING**

---

- **Do not operate the Anesthesia System before reading this manual.**
  - **This machine must only be operated by trained, skilled medical staff.**
  - **Usage of accessories found with damaged package may cause biocontamination or failure. The operator should check accessory packaging for integrity before use.**
  - **To dispose of the packaging material, observe the applicable waste control regulations. And keep it out of children’s reach.**
  - **This equipment/system is intended for use by healthcare professionals only. This equipment/system may cause radio interference or may disrupt the operation of nearby equipment. It may be necessary to take mitigation measures, such as reorienting or relocating the device or shielding the location.**
  - **Before putting the system into operation, the operator must verify that the equipment, connecting cables and accessories are in correct working order and operating condition.**
  - **To avoid risk of electric shock, this equipment must only be connected to a supply mains with protective earth. If the installation does not provide for a protective earth conductor, disconnect it from the power line or operate from the equipment’s internal battery supply.**
  - **The mains plug is used to isolate the Anesthesia System circuits electrically from the mains supply. Do not position the Anesthesia System so that it is difficult to operate the plug.**
  - **Multiple AC power outlets are provided on the rear of the unit. These outlets are intended to supply power to additional equipment that form a part of the anesthesia system (i.e. vaporizers, gas analyzers, etc.). Do not connect other equipment to these outlets, as animal leakage current may be affected. Each outlet is rated 3 A; the total current that may be drawn through all outlets is 5 A on the System; do not attempt to exceed these load ratings. Do not connect additional Multiple Socket Outlets (i.e. Multiple outlet extension cords) (MSOs) or extension cords to these outlets. Do not put MSOs on the floor.**
  - **Connecting electrical equipment to MSOs effectively leads to creating an ME (medical electrical) system, and can result in a reduced level of safety.**
-

---

---

 **WARNING**

---

- **Connection of both medical and non-medical equipment to the MSO(s) may increase the leakage currents to values exceeding the allowable limits.**
- **In order to prevent electric shock, the machine (protection class I) may only be connected to a correctly grounded mains connection (i.e., socket outlet with grounding contact).**
- **Connect the Anesthesia System to an AC power source before the internal battery power source is depleted.**
- **All gas supplies should be of medical grade.**
- **Inspect all breathing system components carefully before each use. Ensure all components contain no any obstructions or debris that can cause a potential hazard to the animal.**
- **The use of anti-static or electrically conductive breathing tubes, when utilizing high frequency electric surgery equipment, may cause burns, and is therefore not recommended in any application of this machine.**
- **Ensure that an independent means of ventilation (e.g. a self-inflating manually powered resuscitator with mask) is available whenever this system is in use.**
- **To avoid the possibility of explosion, do not use the equipment in the presence of flammable anesthetic agents, vapors or liquids. Do not use flammable anesthetic agents such as ether and cyclopropane for this equipment. Use only non-flammable anesthetic agents that meet the requirements specified in ISO 80601-2-13. The Anesthesia System can be used with Halothane, Enflurane, Isoflurane and Sevoflurane. Only one anesthetic agent can be used at a time.**
- **Oxygen, when present in high concentrations, can significantly increase the chance of fire or an explosion. Oil and grease may spontaneously ignite and as such should not be used where oxygen enrichment may occur.**
- **Fresh gas flow must never be switched off before the vaporizer is switched off. The vaporizer must never be left switched on without a fresh-gas flow. Anesthetic agent vapor at a high concentration can get into the machine lines and ambient air, causing harm to people and materials.**
- **Malfunction of the central gas supply system may cause more than one or even all devices connected to it to stop their operations simultaneously.**
- **The anesthesia system will cease to deliver gas at pressures below the minimum specified gas pipeline supply pressure.**
- **Operation of this system below the minimum flow values may cause inaccurate results.**
- **A hazard may exist due to the use of improper connectors. Ensure all assemblies use the proper connectors.**

---

---

 **WARNING**

---

- **This machine should not be used adjacent to or stacked with other equipment. If adjacent or stacked use is necessary, this machine should be observed to verify normal operation in the configuration in which it will be used.**
  - **Leaks or internal venting of sampled gas may affect accuracy. Perform the proper preoperative tests to ensure that the device is performing properly. Leaky circuits can not be used.**
  - **When the ambient temperature is 40 degrees Celsius. The temperature on the surface of the breathing mask may be higher than 41 degrees Celsius, but does not exceed 43 degrees Celsius.**
  - **Do not rely exclusively on the audible alarm system for animal monitoring.**
  - **Adjustment of alarm volume to a low level may result in a hazard to the animal.**
  - **Alarm settings should be customized according to different animal situations. Constantly keeping the animal under close surveillance is the most reliable way for safe animal monitoring.**
  - **The physiological parameters and alarm messages displayed on the screen of the equipment are for the caregiver's reference only and cannot be directly used as the basis for clinical treatment.**
  - **The animal should be visually monitored by qualified personnel. In certain situations, life-threatening circumstances may occur that may not necessarily trigger an alarm.**
  - **Always set the alarm limits so that the alarm is triggered before a hazardous situation occurs. Incorrectly set alarm limits may result in operating personnel not being aware of drastic changes in the animal's condition.**
  - **Ensure that the current alarm presets are appropriate before use on each animal.**
  - **A hazard can exist if different alarm presets are used for the same or similar equipment in any single area.**
  - **If the Drive Gas Pressure Low alarm occurs when the gas supply pressure is greater than 200 kPa, contact your service personnel or Mindray.**
  - **Use extreme care while handling the absorbent as it contains a caustic irritant.**
  - **Review the performance specifications of the disposal system that the transfer and receiving systems are intended to be used with, to ensure compatibility.**
  - **Connection of the exhaust port to the hospital's waste gas scavenging system is strongly recommended to prevent exposure of hospital personnel to the exhaust gases.**
  - **Review the specifications of the AGSS transfer and receiving systems and the specifications of the System to ensure compatibility and to prevent a mismatched receiving system.**
-



---

---

 **WARNING**

---

- **Avoid connecting two or more hose assemblies in series as this may cause a loss of pressure and flow.**
- **Due to the size and weight of this machine, it should only be moved by qualified personnel.**
- **Overloading machine may cause tipping. Equipment attached to the side of the machine should fall within the rated weights to prevent tipping of the machine.**
- **Use extreme caution when moving or resting the unit on surfaces exceeding a 10 degree slope. Before moving, remove all equipment from the top shelf, all monitoring equipment mounted to the side of this machine, all brackets, cylinders, objects on the top self and worktable and in the drawers.**
- **Use care when moving this machine up or down inclines, around corners, and across thresholds. Do not attempt to roll this machine over hoses, cords, or other obstacles.**
- **If this machine is damaged in any way that compromises the safety of the animal or user, discontinue use and attach a visible tag that marks this machine as unusable. Call Mindray Technical Support.**
- **To avoid endangering a animal, do not perform testing or maintenance when the machine is in use.**
- **No modification of this equipment is allowed.**
- **Disconnect the power plug from the mains supply before removing the rear panels or servicing this unit.**
- **The machine may only be opened by authorized service personnel. All servicing and future upgrades must be carried out only by trained and authorized Mindray personnel.**
- **Do not touch the animal when connecting the peripheral equipment via the I/O signal ports or replacing the oxygen cell to prevent animal leakage current from exceeding the requirements specified by the standard.**
- **Low-pressure regulators and flowmeters are susceptible to high pressure, and may burst if improperly maintained or disassembled while under pressure. Changing connectors or disassembling should be performed only by qualified personnel.**
- **Do not disassemble the low-pressure regulator, flow-metering device, or connector while under pressure. The release of sudden pressure may cause injury.**
- **Avoid replacing a high-pressure flexible connection with one of lower nominal inlet pressure.**
- **Use care in lifting and manipulating vaporizers during the mounting process as their weight may be greater than expected, based on their sizes and shapes.**

---

---

 **WARNING**

---

- **Do not use talc, zinc stearate, calcium carbonate, corn starch, or similar material to prevent sticking of the bellows, as these materials may enter the animal's lungs or airway, causing irritation or injury.**
  - **Use of lubricants not recommended by Mindray may increase the danger of fire or explosion. Use lubricants as approved by Mindray.**
  - **Reusing breathing circuits or reusable accessories that are not disinfected may cause cross-contamination. Disinfect the breathing circuits and reusable accessories before use.**
  - **Do not clean the machine while it is powered on and/or plugged into an outlet.**
  - **Use a cleaning and disinfection schedule that conforms to your institution's disinfection and risk-management policies. Refer to the material safety data sheet as applicable. Refer to the operation and maintenance manuals of all disinfection equipment. Do not inhale fumes that may result from any disinfection process.**
  - **Single use respiratory hoses, face masks, sensors, soda lime, watertraps, sampling lines, airway adapters, and other single use items may be considered potential biologically hazardous items and should not be reused. Dispose of these items in accordance with hospital policy and local regulations for contaminated and biologically hazardous items.**
  - **Improperly cleaned materials may result in biocontamination. Use a cleaning and disinfection schedule that conforms to your institution's disinfection and risk-management policies. Refer to the material safety data sheet as applicable. Refer to the operation and maintenance manuals of all disinfection equipment. The user should follow the recommended disinfection routine for this machine and any reusable accessories.**
  - **Before using the System after cleaning or disinfecting, power up the system and follow the on-screen prompts to perform the Leak Test and the Compliance Test.**
  - **The battery replacement by inadequately trained personnel could result in a HAZARD (such as excessive temperatures, fire or explosion).**
  - **The Anesthesia Machine shall not be serviced or maintained while in use with the animal.**
  - **External exhaust outlets of Anesthesia Machine shall not be located to place which has any electrical component.**
  - **For the system intended to be mounted, when removed from its wall or ceiling mount, does not meet the stability requirements of IEC 80601-2-13 and IEC 60601-1 respectively. Special caution has to be taken.**
  - **To avoid the accidental dropping, ensure the large backup cylinder is firmly fixed with the strap.**
-

---

### 1.1.3 Cautions

---

#### CAUTION

---

- To ensure animal safety, use only parts and accessories specified in this manual.
  - At the end of its service life, the equipment, as well as its accessories, must be disposed of in compliance with the guidelines regulating the disposal of such products, and in accordance with local regulations for contaminated and biologically hazardous items.
  - Magnetic and electrical fields are capable of interfering with the proper performance of the equipment. For this reason ensure that all external devices operated in the vicinity of the equipment comply with the relevant EMC requirements. Mobile phone, X-ray equipment or MRI devices are a possible source of interference as they may emit higher levels of electromagnetic radiation.
  - This system operates correctly at the electrical interference levels identified in this manual. Higher levels can cause nuisance alarms that may stop mechanical ventilation. Be aware of false alarms caused by high-intensity electrical fields.
  - Perform the daily checks specified on the checklist. In case of a system fault, do not operate the system until the fault has been corrected.
  - Before starting the machine, users must be familiar with the information contained in this Operator's Manual and must have been trained by an authorized representative.
  - If the machine does not function as described, it must be examined and repaired as necessary by qualified service personnel before being returned to use.
  - Handle the machine with care to prevent damage or functional faults.
  - Ensure that the gas supply of the machine always complies with the technical specifications.
  - Before clinical use, the machine must be correctly calibrated and/or the respective tests must be performed, as described in this Operator's Manual.
  - If system faults occur during the initial calibration or testing, the machine should not be operated until those faults have been corrected by a qualified service person.
  - After servicing, functional, sensor, and system tests must be performed before clinical use.
  - Only vaporizers with Selectatec Interlock-Systems may be used with this unit.
  - After each exchange of a vaporizer, perform a vaporizer leak test.
  - Use cleaning agent sparingly. Excess fluid could enter the machine, causing damage.
-

---

---

 **CAUTION**

---

- Do not autoclave any parts of the system unless specifically identified as autoclavable in this manual. Clean the system only as specified in this manual.
- Refer to the literature supplied by the manufacturer of the cleaning agent.
- Never use organic, halogenated or petroleum-based solvents, anesthetics, glass cleaning agents, acetone or other irritant agents.
- Never use abrasive agents (i.e. steel wool or silver polish) to clean components.
- Keep all liquids away from electronic components.
- Prevent liquid from entering the equipment.
- All cleaning solutions used must have a pH between 7.0 and 10.5.
- Never immerse the oxygen sensor or its connector in any type of liquid. Dispose of the oxygen sensor as per the local regulations.
- Do not use acetic hydroperoxide or formaldehyde steaming.
- The valve disc in each of the inhalation and exhalation valve assemblies on the breathing system is fragile and must be handled with care while removing the valve cage from the valve assembly.
- If moisture remains in the bellows after cleaning, the bellows surface folds may become tacky and prevent the bellows from properly expanding. Ensure all moisture is removed from the bellows after cleaning.
- Only connect Mindray approved equipment to the communication ports.
- Do not connect any non-isolated devices to the DB9/RS232C interface of this unit.
- Do not connect any devices to the USB ports other than Mindray approved USB storage devices and a supported USB mouse.
- Do not wash the inner surface of the oxygen sensor.
- Do not autoclave the following components: airway pressure gauge, oxygen sensor, and flow sensor. These components cannot withstand immersion or the heat and pressure of autoclaving.
- Users should monitor oxygen percentage (FiO<sub>2</sub>%) when using the Auxiliary O<sub>2</sub>/Air Flow Meters. Unknown oxygen concentrations may be delivered to the animal unless oxygen monitoring is used.
- Do not use the O<sub>2</sub> sensor when its service life expires.
- This unit is NOT suitable for use in a magnetic resonance imaging (MRI) environment.
- To ensure measurement accuracy and to avoid possible damage to this unit, use only Mindray-approved cables and accessories.
- Use the power cord provided with the product. If a substitute is necessary, use power cord in compliance with the specification.

---

---

 **CAUTION**

---

- Do not use a damaged or broken unit or accessory. Periodically check all cables (e.g., AC line cord and animal connection cables) for damage that may occur through normal use. Replace cables if damaged in any way.
  - Use of other oxygen sensors may cause improper oximeter performance.
  - Unintended movement may occur if the casters are not locked. The operator should lock casters during use of the machine.
  - Unsecured devices may slide off the top shelf. Devices should be securely attached to the top shelf.
  - The voltage on the auxiliary outlets is the same voltage as the outlet into which this machine is plugged. Ensure that devices plugged into the auxiliary outlets are rated for the same supply voltage as this machine.
  - During the transport and storage of the vaporizer, block the gas inlet and outlet of the vaporizer with plugs to prevent foreign substances from entering the vaporizer.
  - Do not use any flow outlets as handles for moving this machine. The flow outlets may become damaged. Use the metal side bars on the main body when moving this machine.
  - Do not push down on the bag arm forcefully or hang heavy objects onto it. Excessive weight may bend and damage the bag arm.
  - Avoid factors that can contribute to deterioration of the hose assemblies. Factors include excessive bending, crushing, abrasion, system pressures and temperatures that exceed hose ratings, and improper installation.
  - Use care in lifting and manipulating the breathing system block during removal from its mounting arm as handling may be awkward due to its weight and shape.
- 

### 1.1.4 Notes

#### NOTE

---

- Illustrations in this manual are provided for reference purposes only. Screens may differ based on the system configuration and selected parameters.
  - Put the equipment in a location where you can easily see the screen and access the operating controls.
  - Keep this manual close to the equipment so that it can be obtained conveniently when needed.
  - The software was developed in compliance with IEC 62304. The possibility of hazards arising from software errors is minimized.
-























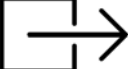
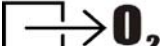

---











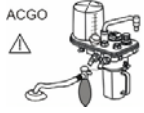













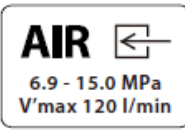
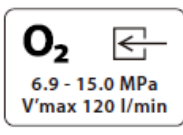

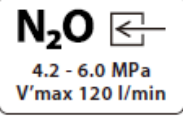

## NOTE

---

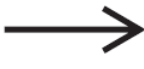















- This manual describes all features and options. Your equipment may not have all of them.
  - Continuously monitor the anesthetic agent concentration when using the Anesthesia System to ensure accurate output of the anesthetic agent.
  - Check the liquid level of the anesthetic agent before and during all operations. When the liquid level is below the warning line, more anesthetic agent needs to be added. Refer to the vaporizer Instructions For Use for filling the vaporizer and other information.
  - The battery supply is not a user serviceable component. Only an authorized service representative can replace the battery supply. If the system is not used for an extended period, contact a service representative to have the battery supply disconnected. The batteries may be subject to local regulations regarding disposal. At the end of the battery life, dispose of the battery supply in accordance with local regulations.
  - Areas designated for the servicing of oxygen equipment shall be clean, free of oil and grease, and not used for the repair of other equipment.
  - Opening the cylinder valve quickly may cause unexpected pressure differentials and create a potential for fire or explosion arising from oxygen pressure shocks. Open and shut the cylinder valve slowly.
  - Accuracy of the flow rate may be affected by varying inlet pressure, varying outlet resistance, or varying ambient temperature.
  - The power device, terminal units and pipeline system can be supplied by one or several different manufacturers.
  - For the method of connecting this system to external monitor or other devices, please see Anesthesia Machine Bracket Installation Instructions.
  - Tidal volume and MV are displayed under BTPS condition. Flow rates are displayed under STPD condition.
  - The Anesthesia System can be used with O<sub>2</sub>, N<sub>2</sub>O, and Air.
  - The operator of the equipment should be situated in front of the equipment and remain 4 m at most from the display for the convenience of viewing the information displayed on the equipment.
  - All materials of this product are latex-free.
-

## 1.2 Equipment Symbols



	Caution		Consult Operator's Manual
	Refer to the instruction manual/booklet		General warning sign
	Environment: Temperature Range		Environment: Humidity Range
	Environment: Pressure Range		Gas Cylinder
	Gas Pipeline Connection		Light
	Power On		Power Off
	Alternating Current (AC)		Fuse or circuit breaker
	Gas Inlet, or sample gas return port (to the AGSS)		Gas Outlet
	Auxiliary O <sub>2</sub> supply		Negative pressure suction device
	Internal Battery		Equipotential connector
	Gas Flow Total		Upgrade debugging port
<b>134°C</b>	Autoclavable		Not autoclavable
>PSU<	Polysulfone	>PPSU<	Material description
	Filter Access		Water Drain
	ACGO separate outlet		Water Trap

	ACGO switch on		ACGO switch off
	Manufacturer's Reference/Catalog Number		Serial number Indicator
	O <sub>2</sub> sensor port		O <sub>2</sub> flush button
	Lock the lifting device		Unlock the lifting device
	Bag position/ manual ventilation		Mechanical ventilation
	Lock		Unlock
	Lock or unlock as the arrow shows		Flow control
	Air supply inlet		O <sub>2</sub> supply inlet
	Upward (Pop-off valve)		N <sub>2</sub> O supply inlet
	Backup cylinder		AGSS outlet
	Manufacture date		Manufacturer
	APL valve		Gas input direction
	Maximum level of the CO <sub>2</sub> absorbent canister		CAUTION HOT
	Approximate		Max. weight: 30 kg
	Gas Flow: Maximum		Do Not Crush

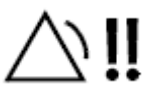
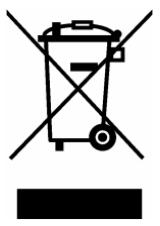

	Type BF applied part. Defibrillation-proof protection against electric shock.	<b>MIN</b>	Gas Flow: Minimum
	Do Not Oil		Pipeline
	Canister opened		European community representative
	No pushing		Canister closed
	Standby key		MR Unsafe – do not subject to magnetic resonance imaging (MRI)
	Alarm key		Setup key
	Alarm icon		Audio pause key
	Alarm audio off icon		Alarm audio pause icon
	Low priority message		Medium priority message
	High priority message		Breathing System Warmer Off
IPX1	Protection against vertically falling water drops for the system.		
	<p>The following definition of the WEEE label applies to EU member states only. This symbol indicates that this product should not be treated as household waste. By ensuring that this product is disposed of correctly, you will help prevent bringing potential negative consequences to the environment and human health. For more detailed information with regard to returning and recycling this product, please consult the distributor from whom you purchased it.</p> <p>* For system products, this label may be attached to the main unit only.</p>		

---

	<p>The product bears CE mark indicating its conformity with the provisions of the Council Directive 2014/35/EU concerning devices. Note: The product complies with the Council Directive 2011/65/EU.</p>
	<p>Unified circulation mark indicates that products marked them passed all specified in the technical regulations of the Customs Union of the procedure for the assessment (confirmation) of conformity and complies with the requirements applicable to all the products technical regulations of the Customs Union.</p>

# 2 The Basics

---

---

## 2.1 System Description

### 2.1.1 Intended Use

The anesthesia machine is intended to provide general inhalation anesthesia and ventilatory support to animals.

The anesthesia machine must only be operated by qualified anesthesia personnel or veterinarian who have received adequate training in its use.

---

### **WARNING**

---

- **This anesthesia machine is intended for use by qualified anesthesia personnel or veterinarian only or under their guidance. Anyone unauthorized or untrained must not perform any operation on it.**
  - **This anesthesia machine is not suitable for use in an MRI environment.**
- 

### 2.1.2 Contraindications

The anesthesia machine is contraindicated for use on animals who suffer pneumothorax or severe pulmonary incompetence.

---

### 2.1.3 Components

The anesthesia machine consists of a main unit, anesthetic ventilator, flowmeter, vaporizer assembly (Vaporizer model: V60, and Sigma Delta. Applicable anesthetic agent: Halothane, Enflurane, Isoflurane, Sevoflurane for V60; Enflurane, Isoflurane, Sevoflurane, Halothane for Sigma Delta), breathing system (including airway pressure gauge, bellows, CO<sub>2</sub> absorbent canister, inspiratory and expiratory valves, exhaust valve, Auto/Manual switch, manual bag port, tube connector), AGSS transfer and receiving system, Negative Pressure Suction Device, AG module, CO<sub>2</sub> module, and accessories.

Connect the animal to the Anesthesia System via the animal breathing circuit.  
The applied parts of the Anesthesia System are breathing tubes, masks, and cables.

For accessories, refer to *13 Accessories*.

The anesthesia machine features the following:

- Automatic leak detection
- Breathing system gas leak compensation and automatic compliance compensation
- Electronic PEEP
- Automatic N<sub>2</sub>O cut-off in case of low O<sub>2</sub> supply pressure
- Timer which counts the duration between the start and end of an operation
- Table top light
- Externally connected to a animal monitor which is in compliance with the requirements of relevant international standard
- Storage and review of alarm events
- Auxiliary O<sub>2</sub> supply and active anesthesia gas scavenging system (AGSS)
- Setting CPB alarm mode
- Turning off TV and MV alarms
- Configured with the following ventilation modes: Volume Control Ventilation (VCV), Pressure Control Ventilation (PCV), Pressure Support Ventilation (PS), Synchronized Intermittent Mandatory Ventilation—Volume Control (SIMV-VC) and Synchronized Intermittent Mandatory Ventilation—Pressure Control (SIMV-PC)
- CO<sub>2</sub> and AG module

---

## 2.2 Equipment Appearance

The anesthesia machine can be configured with two types of breathing systems. Anesthesia machine with breathing system compatible with Pre-Pak and anesthesia machine with breathing system not compatible with Pre-Pak are defined here.

### 2.2.1 Front View

#### —Display and control panel

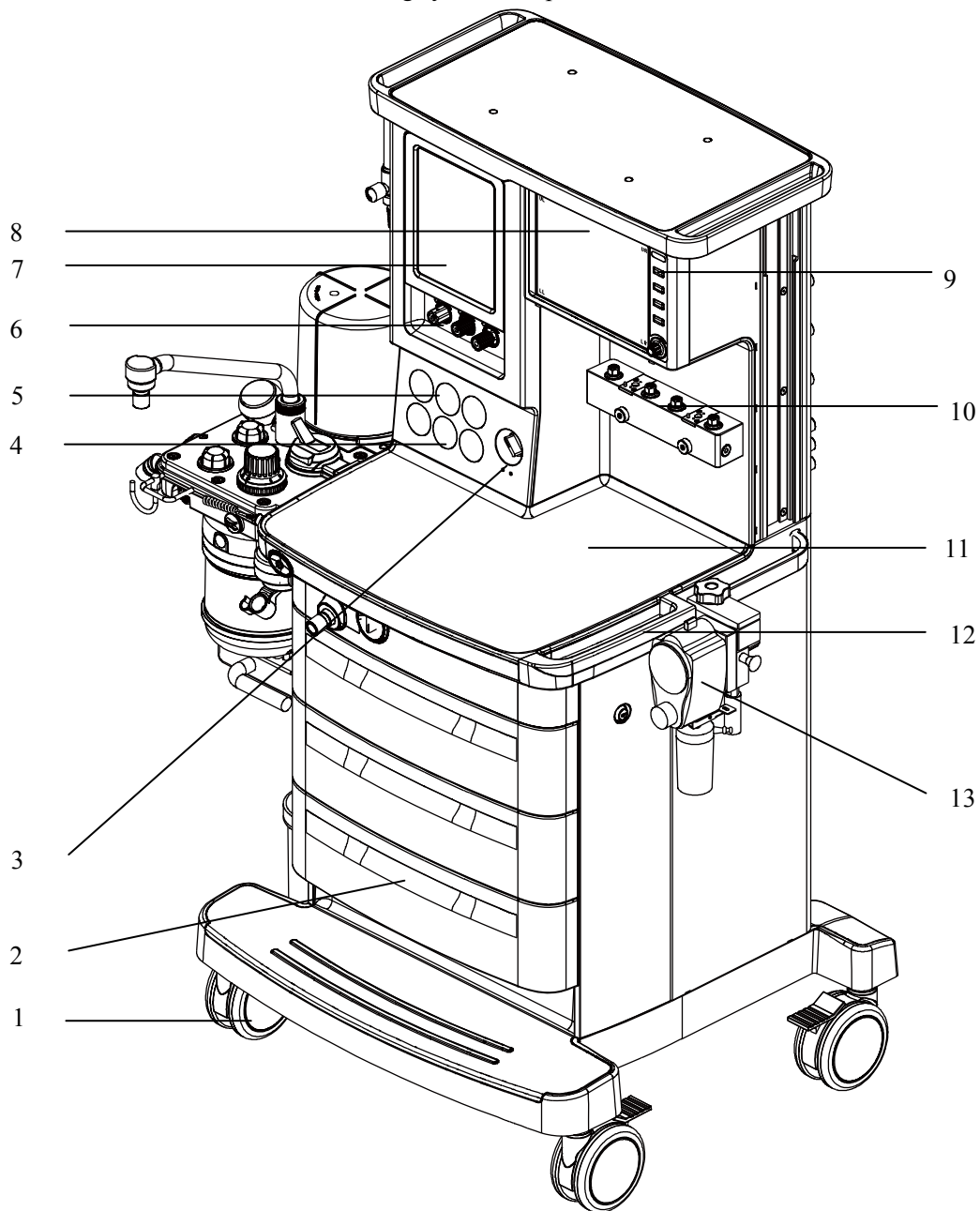

Anesthesia machine with breathing system compatible with Pre-Pak:

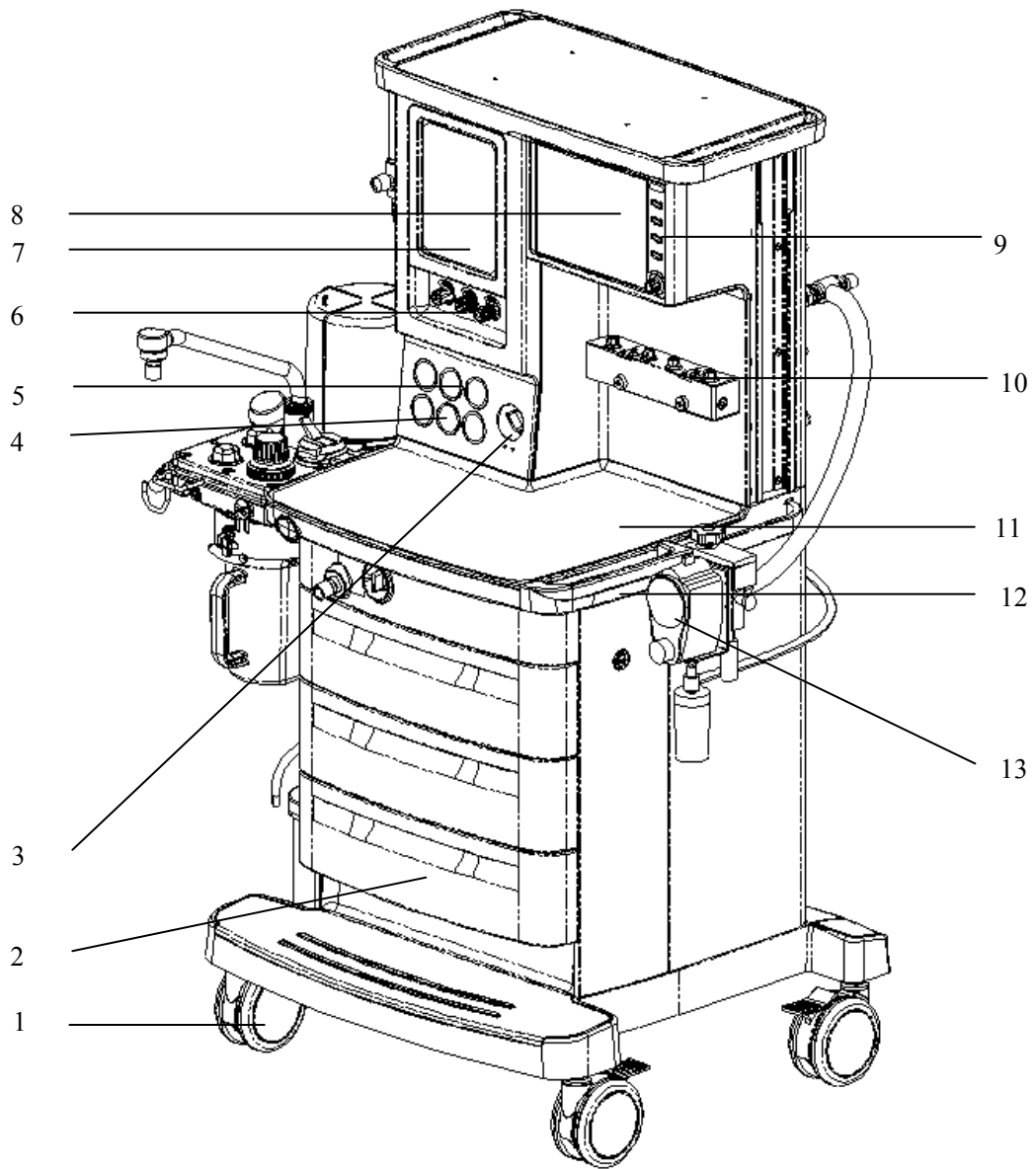

---

Anesthesia machine with breathing system not compatible with Pre-Pak:



- 
1. Caster
  2. Drawer
  3. System switch
    - ◆ Set the switch to the  position to enable gas flow and to turn on the system.
    - ◆ Set the switch to the  position to disable gas flow and to turn off the system.
  4. Cylinder pressure gauge(s)

High-pressure pressure gauge(s) that displays cylinder pressure before relief.
  5. Pipeline pressure gauge(s)

Displays the pipeline pressure or the cylinder pressure after relief.
  6. Flow control(s)

When the system switch is set to the ON position:

    - ◆ Turn the control counterclockwise to increase the gas flow.
    - ◆ Turn the control clockwise to decrease the gas flow.
  7. Flowmeter

The top level of flowtube float indicates the current gas flow. There are two flowtubes available for each gas. When the reading on the first flowtube does not come to the maximum, the reading on the first flowtube represents the current gas flow. When the reading on the first flowtube comes to the maximum, the reading on the second flowtube represents the current gas flow.
  8. Display
  9. Anesthetic ventilator control panel
  10. Manifold

The vaporizer can be mounted onto the manifold.

    - A. Concentration control

Push and turn the concentration control to set the concentration of anesthetic agent.
    - B. Locking lever

Turn the locking lever clockwise to lock the vaporizer in position.
  11. Worktable
  12. Handle
  13. Negative pressure suction device

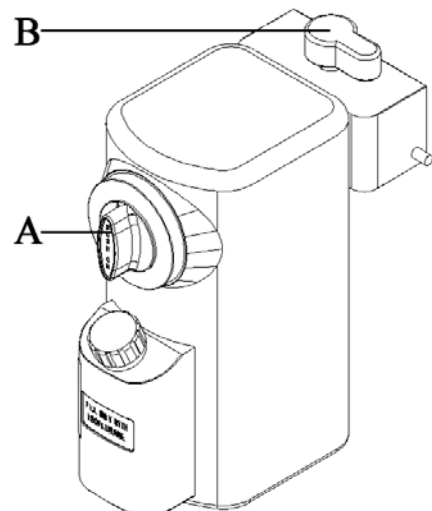

---

## —Breathing system

Anesthesia machine with breathing system compatible with Pre-Pak:

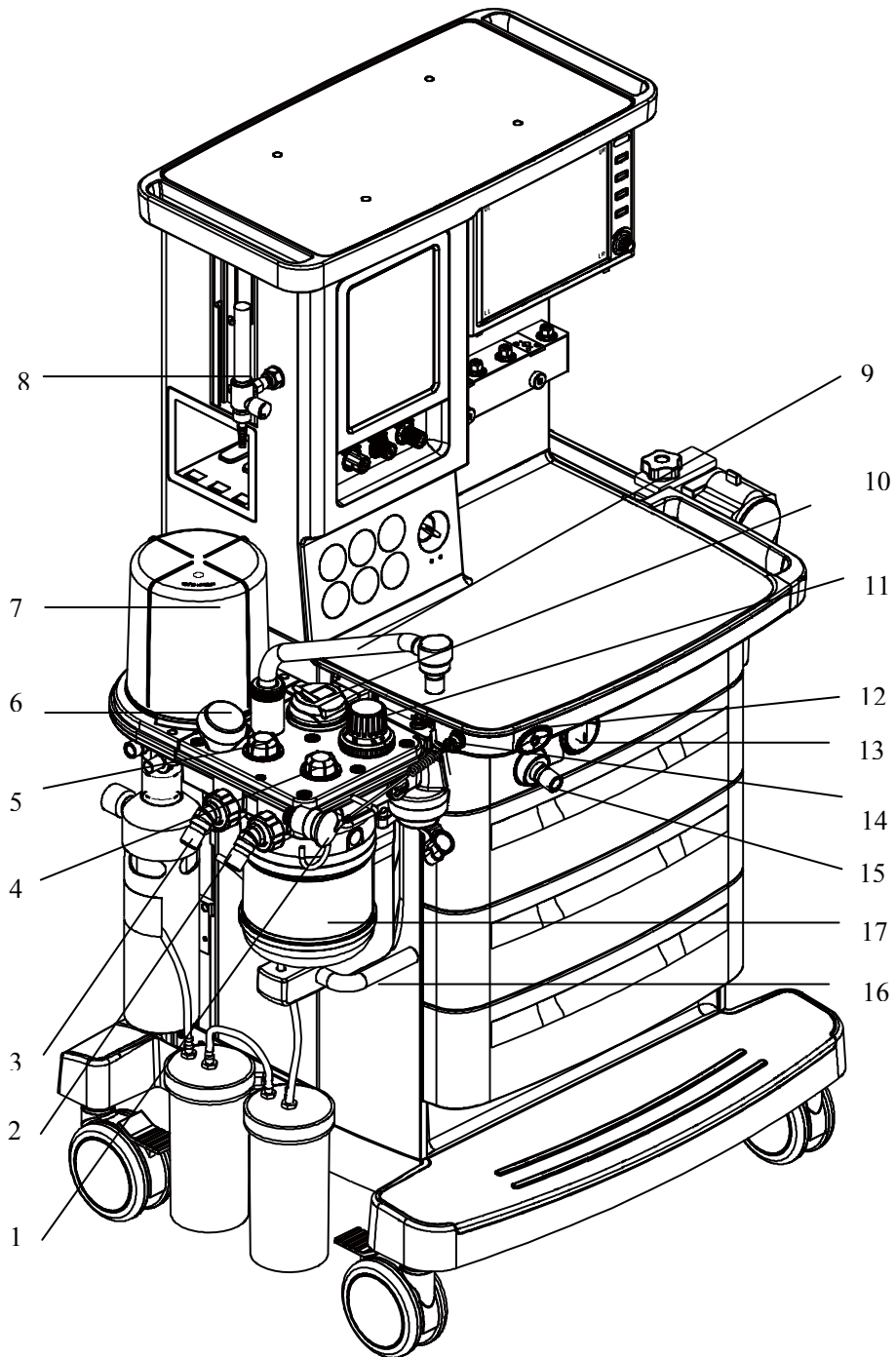



---

Anesthesia machine with breathing system not compatible with Pre-Pak:

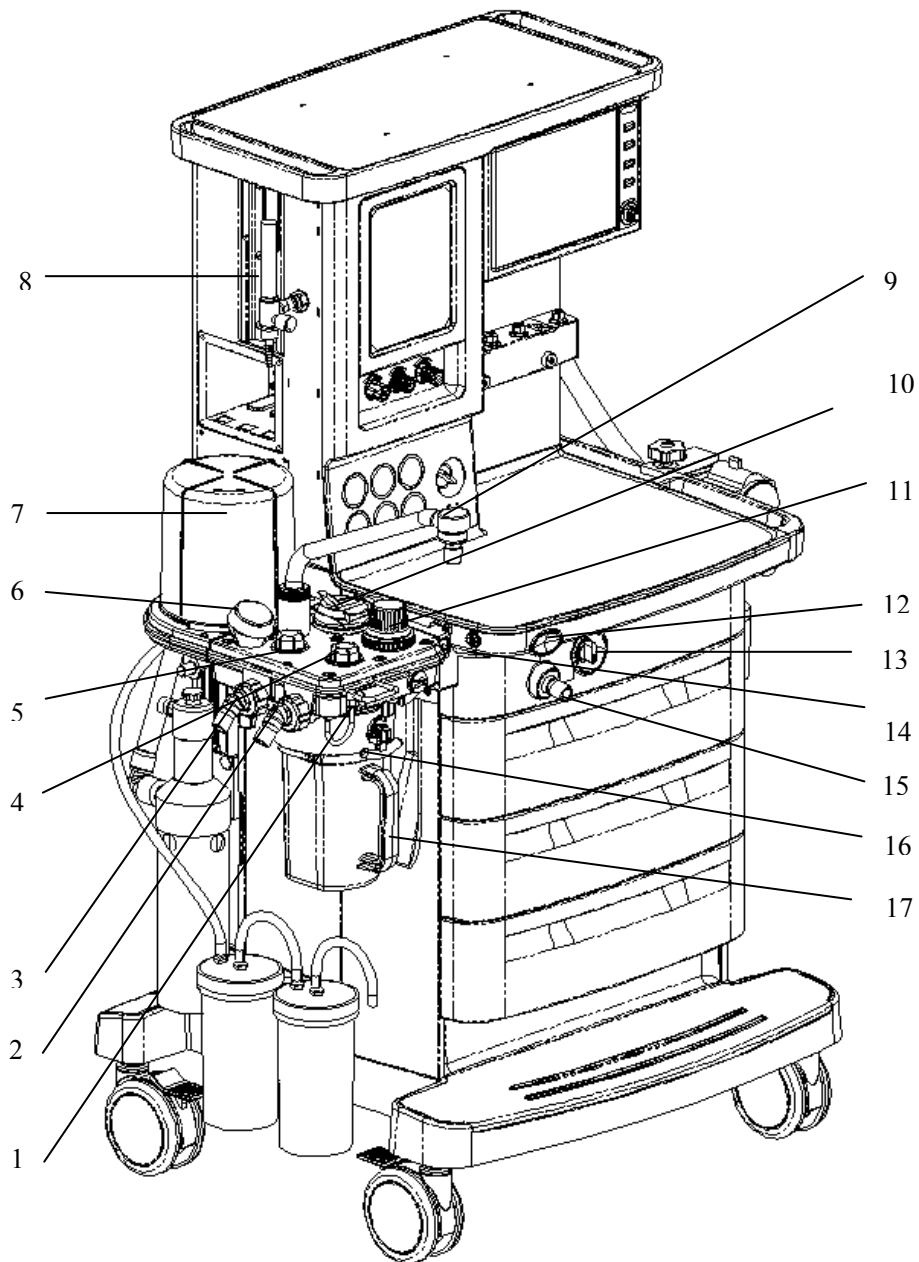

1. O<sub>2</sub> sensor connector
2. Inspiration connector
3. Expiration connector
4. Inspiratory check valve
5. Expiratory check valve
6. Airway pressure gauge
7. Bellows housing

---

8. Auxiliary O<sub>2</sub> supply

9. Bag arm

10. Bag/mechanical ventilation switch

◆ Select the  position to use bag for manual ventilation.

◆ Select the  position to use ventilator for mechanical ventilation.

11. APL (airway pressure limit) valve

Adjusts breathing system pressure limit during manual ventilation. The scale shows approximate pressures. Above 30 cmH<sub>2</sub>O, you will feel clicks as the knob turns. Turn clockwise to increase.

12. O<sub>2</sub> flush button

Push to supply high flows of O<sub>2</sub> to the breathing system.

13. ACGO (Auxiliary Common Gas Outlet) switch

◆ Select the  or  position to stop mechanical ventilation.

When the switch is activated, fresh gas is sent to an external manual breathing system through the ACGO. The screen prompts [ACGO On] and the symbol "ACGO" is displayed. The system monitors airway pressure and O<sub>2</sub> concentration instead of volume.

◆ Select the  position to apply manual or mechanical ventilation to the animal through the breathing system.

14. Connector for O<sub>2</sub> sensor cable

15. ACGO separate outlet

16. Rotary handle

17. CO<sub>2</sub> absorbent canister

The sodalime inside the canister absorbs the CO<sub>2</sub> the animal exhales, which enables cyclic use of the animal exhaled gas.

---

## 2.2.2 Rear View

Anesthesia machine with breathing system compatible with Pre-Pak:

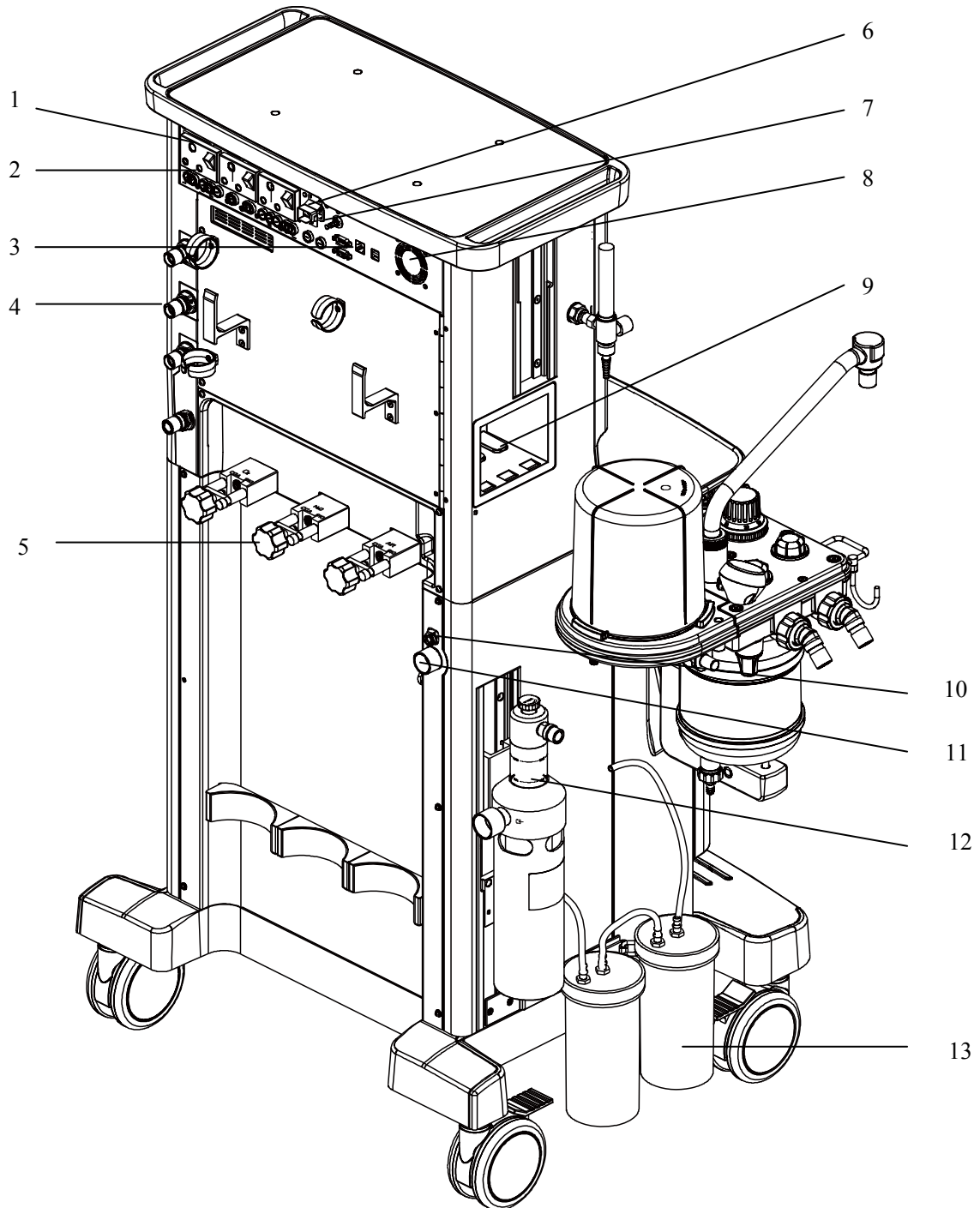

---

Anesthesia machine with breathing system not compatible with Pre-Pak:

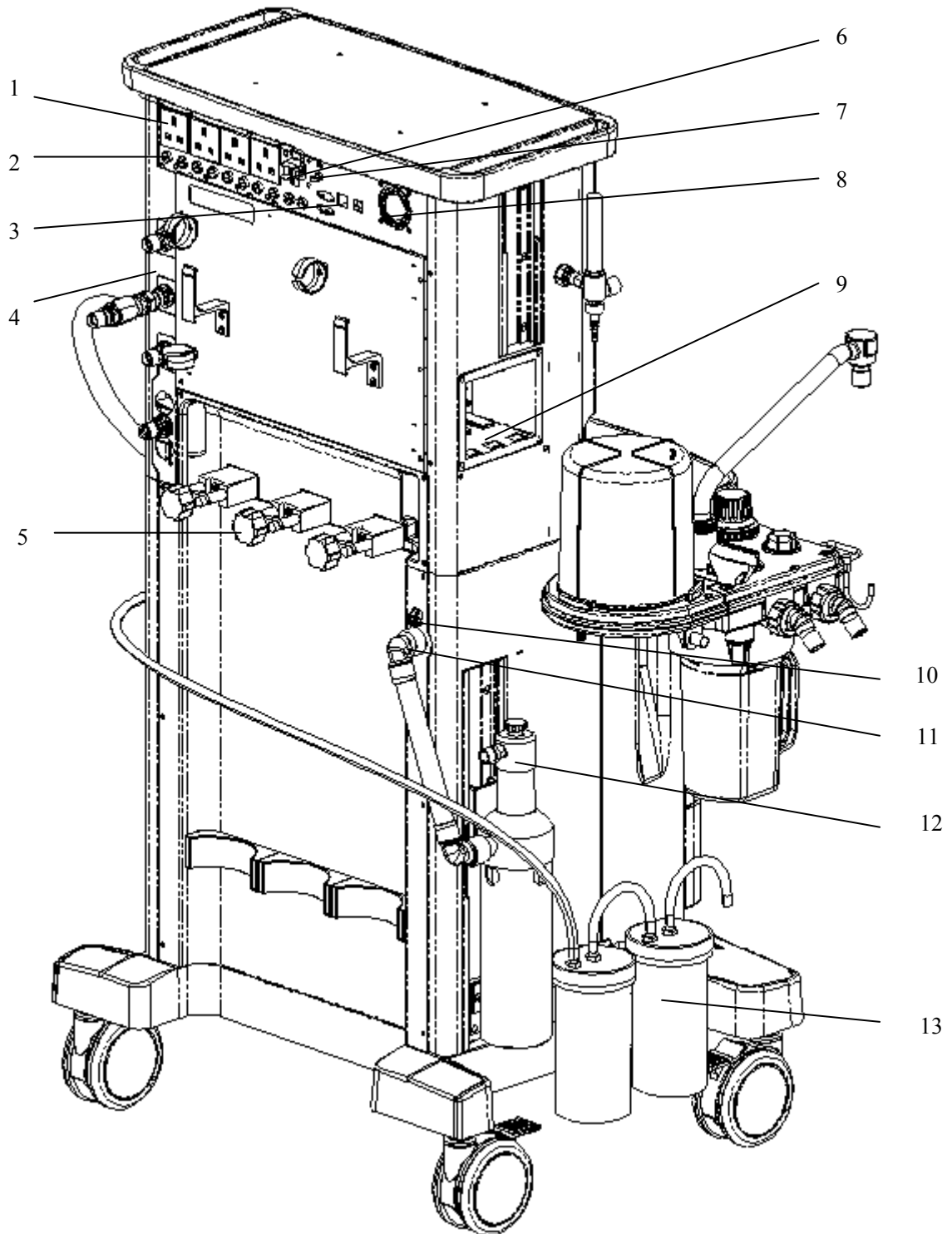

The above picture shows the rear view of the anesthesia machine when it is configured with isolation transformer.

1. Auxiliary AC Outlets

Four Auxiliary AC Outlets.

2. Fuse

3. Communication Ports

A. RS-232 communication port

B. Network port (Connect with the anesthesia information system through HL7 protocol)

C. SB ports

D. Calibration port

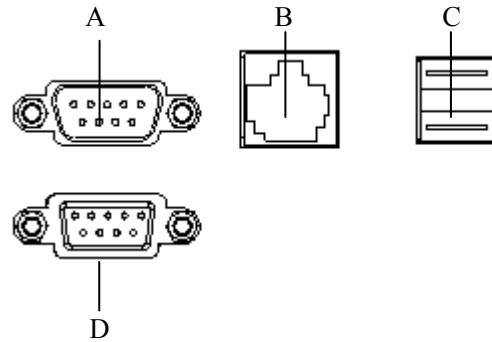

4. Gas supply inlet (s)

a. With backup cylinder

A. N<sub>2</sub>O

B. O<sub>2</sub>

C. Air

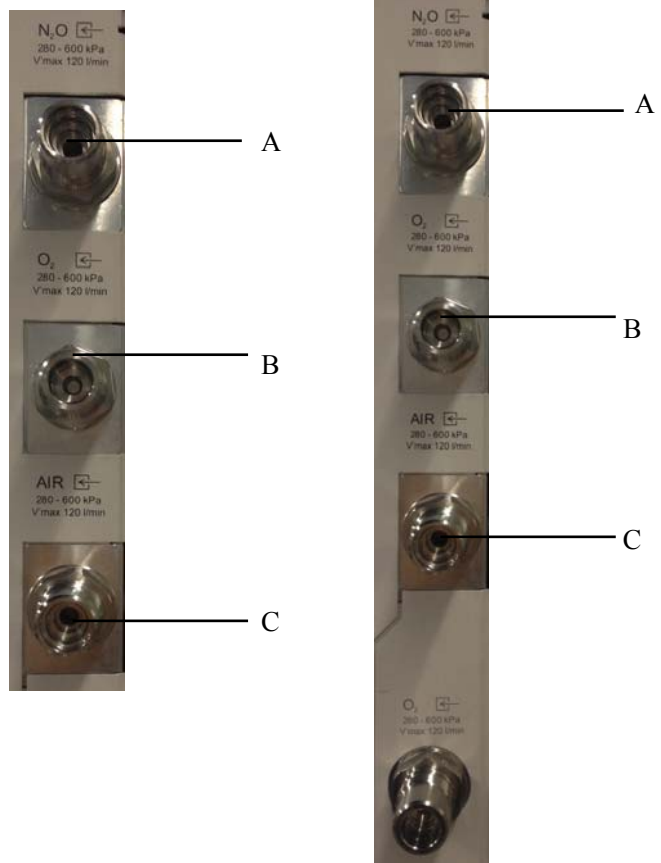

b. Without backup cylinder

A. N<sub>2</sub>O

B. O<sub>2</sub>

C. Air

D. Backup O<sub>2</sub> supply

5. Cylinder connector(s)

6. Mains Inlet

- 
7. Equipotential stud / lug  
Provides a ground point. Eliminates the ground potential difference between different devices to ensure safety.
  8. Fan  
If the fan stops, buzzer will produce audible alarm.
  9. Module slot  
CO<sub>2</sub> and AG modules mentioned in this manual can be inserted into the slot and identified. The CO<sub>2</sub> and AG modules cannot be used simultaneously.
  10. Sample line exhaust gas inlet
  11. AGSS outlet  
Connects to the AGSS or waste gas disposal system.
  12. AGSS transfer and receiving System
  13. Liquid collection bottle

---

Anesthesia machine with large backup cylinder:

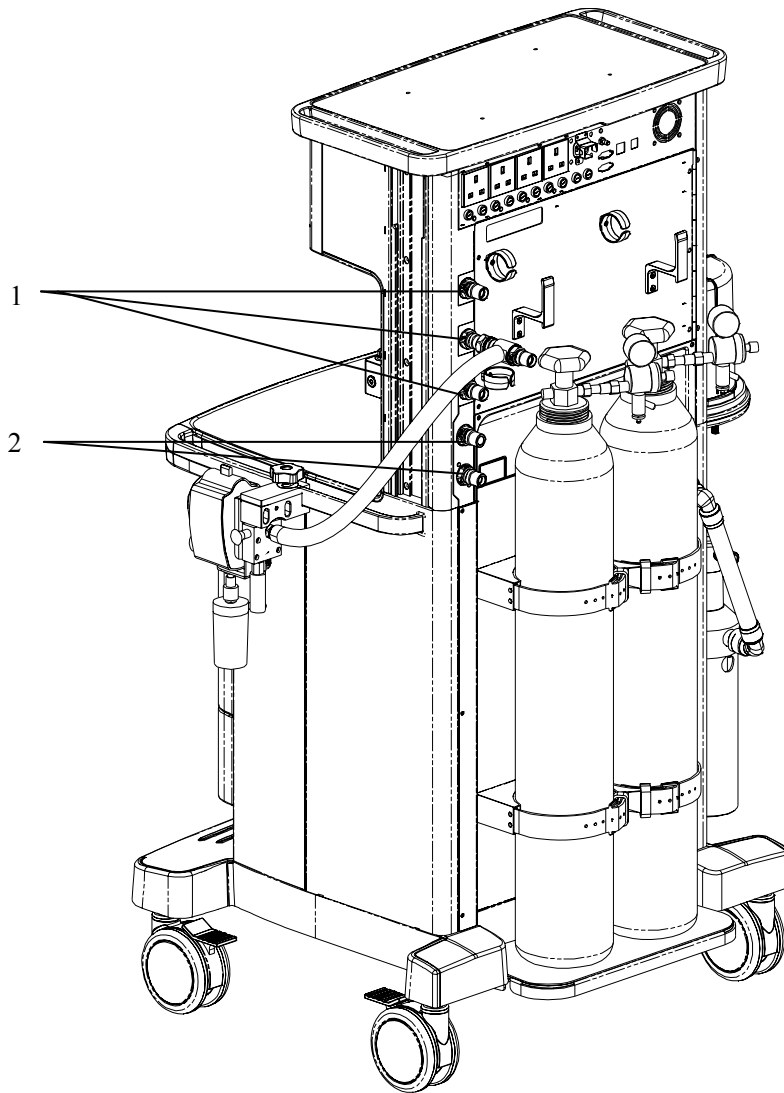

1. Pipeline supply inlet (s)
2. Large backup cylinder inlet (s)

---

**⚠ WARNING**

- **Connect to the AC mains in compliance with B.3 Power Requirements. Failure to do so may cause damage to the equipment or affect its normal operation.**
  - **Make sure that the jacket on the electrical outlet is already fixed to avoid power cord off during surgery.**
  - **The breaker may be in power off state due to some equipment failure. Check the equipment for malfunction. Before equipment use, make sure that the breaker is in power on state and the equipment is powered by AC mains.**
-

---

## **NOTE**

---

- **If the breaker cannot be dialed to power on state, it indicates that the equipment is short-circuited. Check whether the fuse is normal. If the problem persists after the replacement of the new fuse, please contact the service personnel.**
  - **When the anesthesia machine is configured with auxiliary electrical outlets, the equipment connected to the auxiliary electrical outlets shall comply with the voltage and current specifications of the outlets. Equipment connected to the auxiliary electrical outlet shall be authorized. Otherwise, leakage current above the allowable limit will result, which may endanger the animal or operator, and damage the anesthesia machine or externally connected equipment.**
  - **When the auxiliary electrical outlet does not work normally, check if the corresponding fuse is burned.**
  - **All analog or digital products connected to this system must be certified passing the specified IEC standards (such as IEC 60950 for data processing equipment and IEC 60601-1 for medical electrical equipment). All configurations shall comply with the valid version of IEC 60601-1. The personnel who are responsible for connecting the optional equipment to the I/O signal port shall be responsible for medical system configuration and system compliance with IEC 60601-1 as well.**
-



---

## 2.2.3 Pendant-mounted Anesthesia Machine

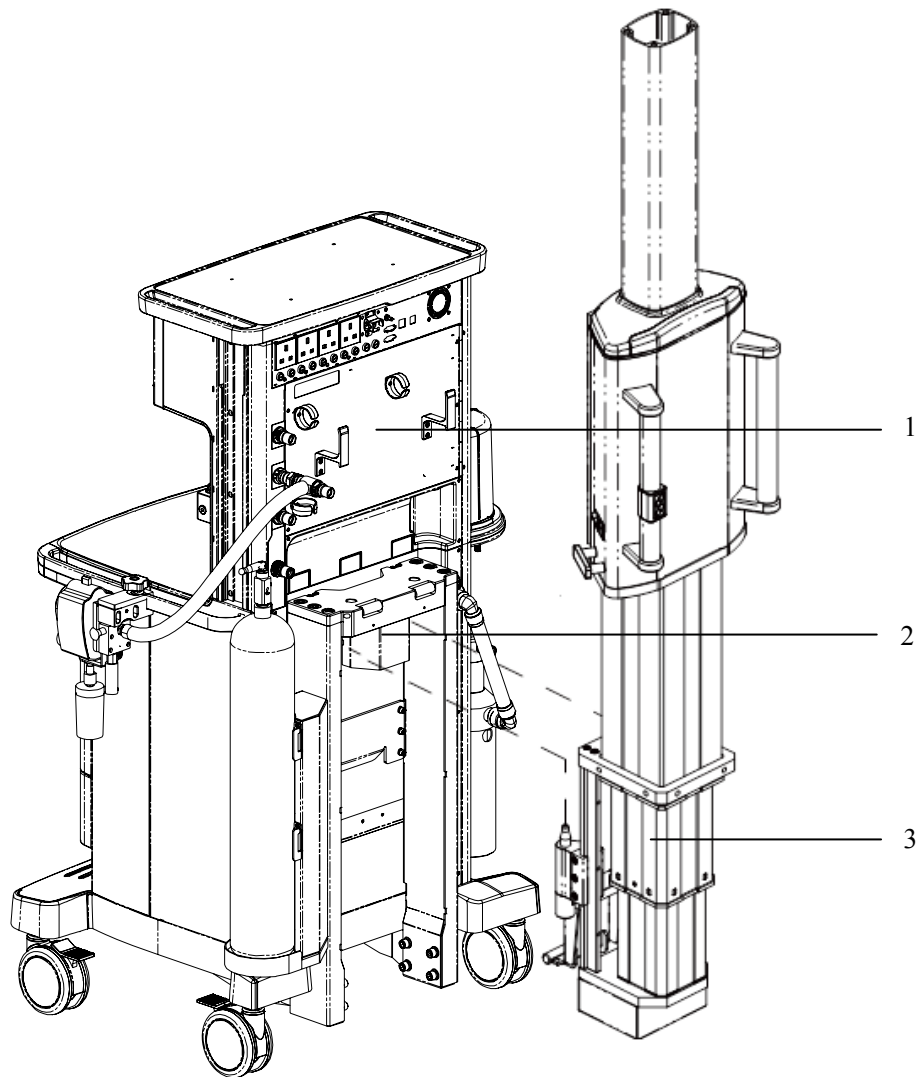

1. Anesthesia machine
2. Bracket
3. Pendant

The anesthesia machine can be mounted onto the pendant through the bracket.

---

## 2.3 Batteries

### NOTE

---

- **Use batteries at least once every month to extend their life. Charge the batteries before their capacities are worn out.**
  - **Inspect and replace batteries regularly. Battery life depends on how frequent and how long it is used. For a properly maintained and stored lithium battery, its life expectancy is approximately three (3) years. For more aggressive use models, life expectancy can be shortened. Replacing lithium batteries every three (3) years is recommended.**
  - **The operating time of a battery depends on equipment configuration and operation. For example, starting module monitoring frequently will shorten the operating time of the batteries.**
  - **In case of battery failure, contact us or have your service personnel replace it. Do not replace the battery without permission.**
- 

The anesthesia machine is designed to operate on battery power whenever AC power becomes interrupted.

When the anesthesia machine is connected to the AC power source, the batteries are charged regardless of whether or not the anesthesia machine is currently on. In case of power failure, the anesthesia machine will automatically be powered by the internal batteries. When AC power source is restored within the specified time, power supply is switched from battery to AC automatically to ensure continuous system use.

The capacity of the internal battery is limited. If the battery capacity is too low, power supply failure will result. A high-level alarm will be triggered and the **[Low Battery Voltage!]** message displayed in the technical alarm area. In this case, apply AC power to the anesthesia machine. If the AC power is not restored in time, the electrical system including screen, alarm system and mechanical ventilation system cannot function.

# 3 System Controls and Basic Settings

## 3.1 Display Screen



The anesthesia machine adopts a high-resolution color TFT LCD to display various parameters and graphs, such as ventilation parameters and pressure/flow/volume waveforms. Depending on how your anesthesia machine is configured, it may display gas module parameters and waveforms.

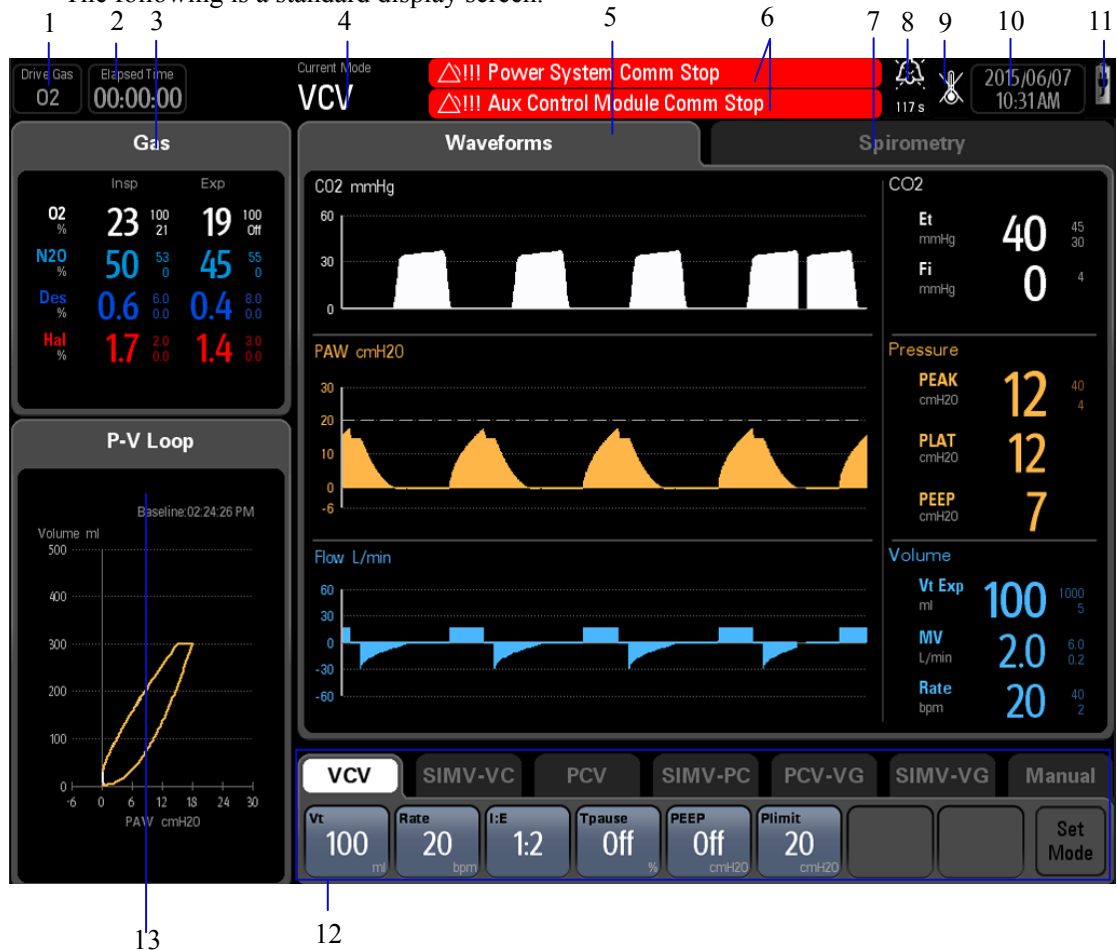

The following is a standard display screen.





1. Drive Gas

Displayed if configured with Drive Gas Auto Switch function. It displays current drive gas type. When the primary drive gas pressure is low and the temporary drive gas pressure is normal, select [Yes] from the pop-up dialog box to switch to the temporary drive gas. When the primary drive gas pressure resumes, select [Yes] from the pop-up dialog box to switch to the primary drive gas. When the area displays the temporary drive gas or the primary drive gas pressure is low, you can select the area to open the [Drive Gas] menu and set the drive gas in the menu.

- 
2. Elapsed Timer  
Displays elapsed time. Select to start, stop, or reset the timer.
  3. Gas Area  
Displayed when AG module is connected. It displays real-time inspiratory and expiratory levels of gas concentration.
  4. Current Ventilation Mode  
Displays the current ventilation mode.
  5. Waveforms Tab
  6. Alarm / Prompt Message Area  
Displays physiological alarms, technical alarms, and prompt messages. The most recent highest priority alarm is displayed at the top.  
  
The remaining alarms are displayed in the lower area and grouped by priority. The most recent of these alarms is displayed first. Select this area to display a list of all Active Alarms. Select  to review the information of the alarm.  
  
High priority messages are red. Medium priority messages are yellow. Low priority messages are cyan. Prompt messages are white.
  7. Spirometry Tab
  8. Alarm Audio Pause Icon  
  
Displays the alarm audio pause icon and countdown timer for 120 s when the  key is selected.
  9. Breathing System Warmer Icon  
Indicates the warmer is not active.
  10. System Date and Time  
Displays the current system date and time.
  11. Main Power Supply and Battery Status Icon  
Displays the main power supply and battery state.

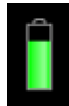
Part	Description
	Battery supply is fully charged. AC power is connected. The system is being powered by AC power. The solid portion represents the current charge level of the batteries in proportion to its maximum charge level.
	Battery supply is partially charged. AC power is connected and charging battery supply. The system is being powered by AC power.

	Battery supply is fully charged. AC power is not connected. The system is being powered by internal battery supply.
	Battery supply is partially charged. AC power is not connected. The system is being powered by internal battery supply.
	Battery supply is low charged. Batteries need to be charged immediately to operate as a safe power backup. AC power is not connected. The system is being powered by internal battery supply.
	Battery supply is not installed.

12. Ventilations Mode and Setting Parameters Area

Displays tabs for all ventilation modes. Each tab displays the ventilation mode and its parameters.

13. Spirometry Area

Displays three types of spirometry loops: P-V (Pressure -Volume) loop, F-V (Flow-Volume) loop, and P-F (Pressure-Flow) loop.

### 3.1.1 Waveform Tab

Displays Paw, Flow, Volume, CO<sub>2</sub>, O<sub>2</sub>, N<sub>2</sub>O and AA waveforms.

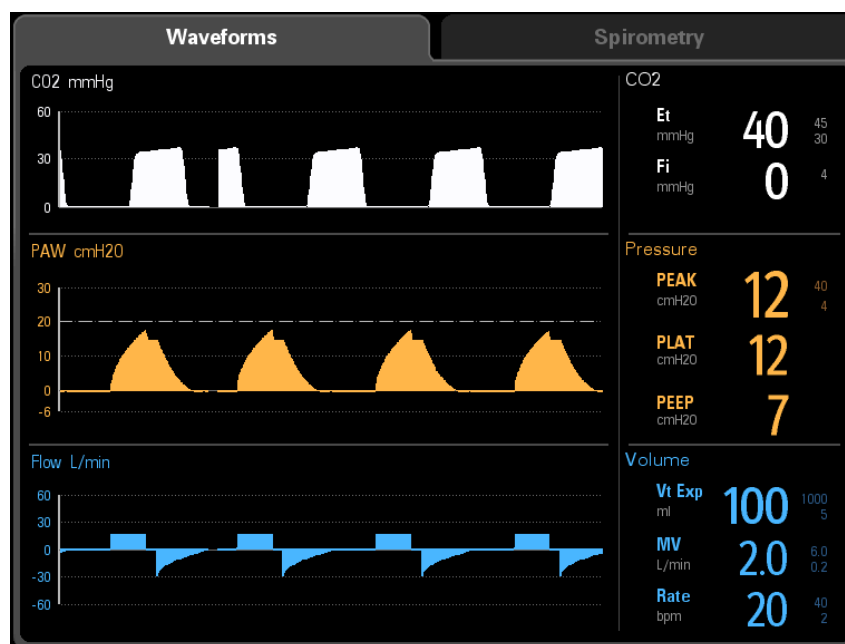

### 3.1.2 Spirometry Tab

Displays separate looped graphs of Pressure-Volume, Flow-Volume and Pressure-Flow.

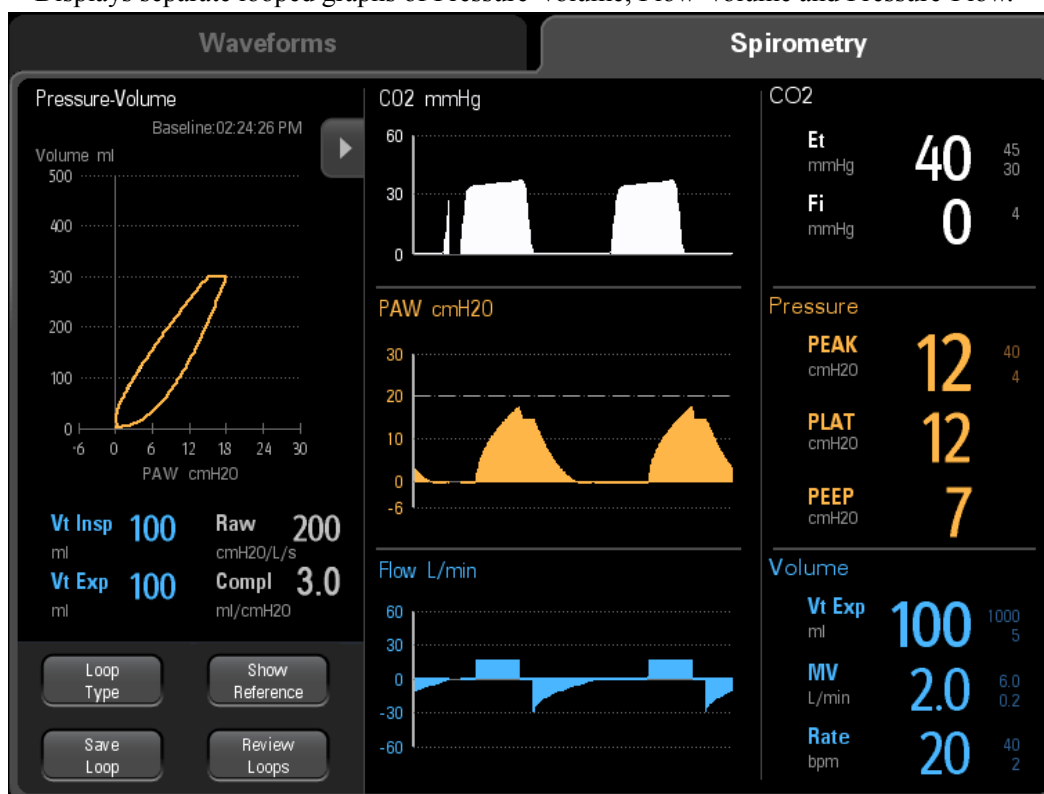

Spirometry loops reflect animal lung function and ventilation. They also indicate other related parameters such as compliance, over-inflation, breathing system leak, and airway blockage.

The system provides three spirometry loops: P-V (Pressure -Volume) loop, F-V (Flow-Volume) loop, and P-F (Pressure-Flow) loop. Data for P-V, F-V, and P-F loops come from pressure, flow, and volume measured data. Only one loop is displayed at one time.

The spirometry tab displays four buttons: **[Loop Type]**, **[Show Reference]**, **[Save Loop]**, and **[Review Loops]**.

- **[Loop Type]:** Select **[P- V Loop]**, **[F- V Loop]**, or **[P- F Loop]** to display on the spirometry screen. Default loop type is **[P- V Loop]**.
- The **[Show Reference]** button can be selected only after a Baseline loop has been saved via the **[Save Loop]** button. The **[Show Reference]** button is used to select and display a saved **[Baseline]** loop, **[Reference]** loop, or no loop (Off) in the spirometry loop window, overlapped with the currently plotting loop. Only the four most recently saved Reference loops are listed chronologically. When a Reference loop or Baseline loop is selected to display in the spirometry loop window, the time stamp will also be displayed.

- 
- Select the [**Save Loop**] button to save the currently plotting loop (including its numeric data) as either a Baseline loop or Reference loop. Only one Baseline loop and up to four Reference loops can be saved. Additional plotting loops can be saved to replace the Baseline loop or Reference loops. Only the four most recent Reference loops are saved. The saved Baseline or Reference loop can be reviewed with its numeric data (via [**Review Loops**] button) or displayed with the currently plotting loop on the same graph for comparison (via [**Show Reference**] button).

### 3.1.3 Ventilation Mode Tab

Displays tabs for all ventilation modes. Each tab displays the ventilation mode and its parameters.

### 3.1.4 Measured Values Area

The Measured Values Area is used to display the numerical data.



### 3.1.5 Elapsed Timer

Located at the top left of the main screen. Select to start, stop, or reset the timer.



---

### 3.1.6 Date and Time

1. Select the Date and Time icon. The **[Date/Time]** dialog is displayed.
2. Use the dialog keypad and softkeys to adjust the date, time, 12/24 hour format, date format, and daylight savings time.

#### **NOTE**

- 
- **If applicable, select [Daylight Savings Time] first before all other settings.**
  - **If the [On]/[Off] button of [Daylight Savings Time] in the [Date/Time] dialog is disabled and cannot be selected, it is because the [Daylight Savings] has been set to [Auto] in the System settings.**
- 

3. Select the **[Accept]** button to save your changes.



---

## 3.2 Display Control



1. Alarm Lamp  
Yellow and red. When high and medium level alarms occur simultaneously, it flashes red only.
2. Audio Pause key  
To set alarm audio pause state, push this key to enter 120 s alarm audio pause status.  
The alarm audio pause symbol  and 120 s countdown time appear in the upper right corner of the screen.
3. Alarm key
4. Menu key  
Push to access the main menu or remove all menus from the screen.
5. Standby key  
Push to enter or exit standby mode.
6. Control knob  
Push to select a menu item or confirm a setting. Turn clockwise or counterclockwise to scroll menu items or change settings.

---

## 3.2.1 Standby Key

Select  key, to enter or exit Standby mode after confirmation.

## 3.2.2 Menu Key

Setup Key opens a setup window, with five tabs for different settings: General, Display, History, System and Service.

### 3.2.2.1 General Tab

1. Select  key → **[General]** tab.
2. The **[General]** tab provides access to perform system leak and compliance tests, calibrate the O<sub>2</sub> sensor and flow sensor, activate or inactivate the breathing system warmer, and set AG or CO<sub>2</sub> if configured.

The **[General]** tab also displays information for the most recent calibrations and leak test results.

### Calibrate O<sub>2</sub> Sensor

Select the  key → **[General]** tab → **[Calibrate O<sub>2</sub> Sensor]** button, to calibrate the O<sub>2</sub> sensor. Follow the on-screen instructions and prompts. Note that information for the last O<sub>2</sub> sensor calibration is displayed next to the button.

### Calibrate Flow Sensor

Select the  key → **[General]** tab → **[Calibrate Flow Sensor]** button, to calibrate the flow sensor. Follow the on-screen instructions and prompts. Note that information for the last flow sensor calibration is displayed next to the button.

### Leak Test / Compliance

The **[Test Leak/Compliance]** button enables the system to perform an automatic leak test and manual leak test, and calculates the compliance for the system.

Select the  key → **[General]** tab → **[Test Leak/Compliance]** button, to perform a leak test. Follow the on-screen instructions and prompts. Note that information for the last Leak Test / Compliance is displayed next to the button.

---

## Breathing System Warmer

Select the  key → [General] tab → [Breathing System] button, set the breathing system [Warmer On] (default) or [Warmer Off]. If the Breathing System is selected

[Warmer Off] or if AC power is not connected, the system displays  icon to indicate that the warmer is not active.

### NOTE

- 
- The breathing system warmer is inactive when the system is powered by the battery supply.
- 

## Set AG



See 9.4 *Make AG Settings*.

## Set CO<sub>2</sub>



See 8.3.2 *Make CO<sub>2</sub> Settings*, or 8.4.2 *Make CO<sub>2</sub> Settings*, or 8.5.2 *Make CO<sub>2</sub> Settings*.

### 3.2.2.2 Display Tab

#### Set Screen Brightness

1. Select  key → [Display] Tab.
2. In the [Screen Brightness] area, select  or  buttons to adjust the screen brightness.
3. Select the [Accept] button to confirm the change, or select [Cancel] button to discard the change.

#### Set Key Click Volume

1. Select  key → [Display] Tab.
2. In the [Key Click Volume] area, select  or  buttons to adjust the volume.
3. Select the [Accept] button to confirm the change, or select [Cancel] button to discard the change.

---

## Clean Screen

1. Select  key → [Display] Tab.
2. Select the [Clean Screen] button.
3. The screen will lock for 10 s for cleaning.

## Calibrate Touch

1. Select  key → [Display] Tab.
2. Select the [Calibrate Touch] button.
3. Follow the on-screen instructions.

## Set Pressure Display

1. Select  key → [Display] Tab.
2. Select the [Pressure Display] button.
3. Choose between [MEAN] and [PLAT].
4. Select the [Accept] button to confirm the change, or select [Cancel] button to discard the change.

## Set Plimit Line

The Plimit line function displays a dashed line in the Pressure waveform area to indicate the Plimit position.

The Plimit line can be displayed in VCV and SIMV-VC mode. The Plimit line function can be switched [On] or [Off] by the user. The default value for [Plimit Line] is [On].

### NOTE

- 
- **The Plimit line does not affect the auto-scaling algorithm. If the Plimit line is turned on but not visible, it may be because the line is positioned off the waveform scale.**
- 

1. Select  key → [Display] Tab.
2. Select the [Plimit Line] button to [On] or [Off].
3. Select the [Accept] button to confirm the change, or select [Cancel] button to discard the change.

---

## Set CO<sub>2</sub> Placement

1. Select  key → [Display] Tab.
2. Select the [CO<sub>2</sub> Placement] button.
3. Choose between [TOP] and [Bottom].
4. Select the [Accept] button to confirm the change, or select [Cancel] button to discard the change.

## Set CO<sub>2</sub> Scale (with CO<sub>2</sub> module connected)

1. Select  key → [Display] Tab → [Gas Scales].
2. Select the [CO<sub>2</sub> Scale] button.
3. Select the desired scale setting: [0-40 mmHg], [0-60 mmHg] or [0-80 mmHg].
4. Select the [Accept] button to confirm the change, or select [Cancel] button to discard the change.

## Set Gas Scale (with AG module connected)

1. Select  key → [Display] Tab.
2. Select the [Gas Scale] button.
3. Select the [CO<sub>2</sub> Scale], [AA Scale], [O<sub>2</sub> Scale] or [N<sub>2</sub>O Scale] button. If one anesthesia agent, such as Sevoflurane, is detected, the system displays [Sev Scale] instead of [AA Scale].
4. Select the desired scale setting.
5. If needed, select the [Load Scales Defaults] button and then select the [Yes] button to restore the factory default configurations.
6. Select the [Accept] button to confirm the change, or select [Cancel] button to discard the change.

## Set Waveform Display

1. Select  key → [Display] Tab.
2. Select the [Waveform Display] button.
3. Choose the desired waveform.
4. Select the [Accept] button to confirm the change, or select [Cancel] button to discard the change.

---

### 3.2.2.3 History Tab

The [History] tab provides access to a history of animal's physiological parameters. The History dialog contains [List Trends], [Graphic Trends] and [Event Log] tab.

#### View Graphic Trends

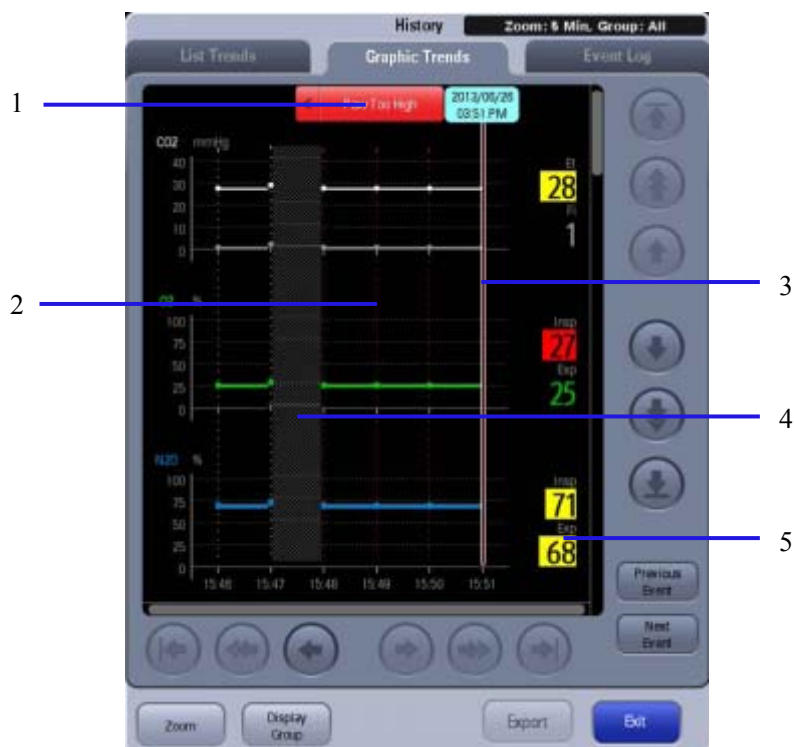













1. Event display area. Displays the event of the current cursor. Click on it to switch to the corresponding item in [Event Log].
2. Event marker. The dotted, colored line indicates an event occurred at that time. Events could be any of the followings: enter Standby mode or a physiological alarm occurrence. When discharge a animal, the dotted line is white. When a physiological alarm occurs, the dotted line is in the same color as the alarm. If multiple events occurred, dotted line is in same color as the event of the highest alarm level. The event level can be specified as: High alarm level event > Medium alarm level even > Low alarm level event > Discharge animal event (if a discharge event occurred during this period)..
3. Current cursor. The corresponding time displays above the cursor. If alarms occurred at that time, the corresponding alarm information will also display above the cursor.
4. Unit was in Standby mode during this period.
5. The parameter data of the time indicated by cursor.

#### NOTE

- **Graphic Trends will be cleared after the anesthesia machine undergoes power failure or is turned off.**

- Graphic Trends store the data with the interval of 1 min.
- Graphic Trends displays the trend records in descending order beginning with the most recent on the right side of the grid.
- Graphic Trends are not stored when the machine is in Standby mode.
- The system can record a rolling 48 h of continuous data.
- Graphic Trends highlights the parameter data in the corresponding alarm color if an alarm condition existed for the parameter at the time of trend record storage.

Button	Function
	Moves the cursor one record back from its current position.
	Moves the cursor one record forward from its current position.
	Moves the cursor up one parameter from its current position.
	Moves the cursor down one parameter from its current position.
	Moves the cursor one page back from its current position.
	Moves the cursor one page forward from its current position.
	Moves the cursor up one page from its current position.
	Moves the cursor down one page from its current position.
	Moves the cursor to the oldest record from its current position.
	Moves the cursor to the newest record from its current position.
	Moves the scroll to the top most parameter from its current position.
	Moves the scroll to the bottom most parameter from its current position.
Previous Event	Moves the cursor to the previous event from its current position.
Next Event	Moves the cursor to the next event from its current position.

---

## View List Trends

The [List Trends] display allows the user to view a tabular list of the physiological parameters. Trend data automatically displays in one minute intervals unless an alternative interval is selected.

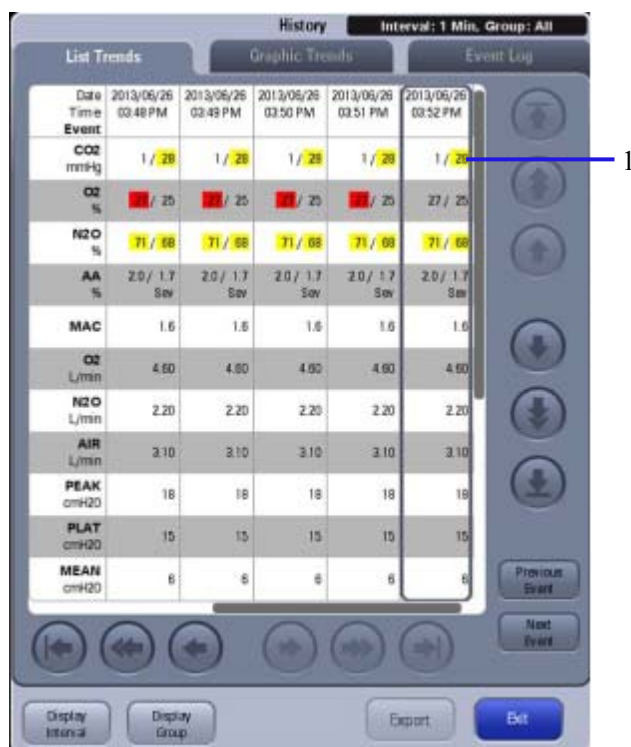

### 1. Current cursor time

- List Trends displays the time and date on the horizontal axis and it is always visible.
- List Trends displays the parameter name on the vertical axis and it is always visible.
- List Trends displays the trend records in descending order beginning with the most recent on the right side of the grid.
- List Trends are not stored when the machine is in Standby mode.
- The system can display a rolling 48 h of continuous data.
- List Trends highlights the parameter data in the corresponding alarm color if an alarm condition existed for the parameter, at the time of trend record storage.



---

## View Event log

The [Event Log] tab logs such events as technical alarms, physiological alarms, delay power off, enter Standby mode, delay power off cancelled and system time change.

An event in the Event Log displays the time, date, event, priority and additional information which includes the Ventilation Mode and Monitored Parameters.

## NOTE

- 
- The system can store up to 500 records of Event Logbook. When a new event occurs after 500 events are already stored, the new event overwrites the earliest one.
- 

### 3.2.2.4 System Tab

The [System] tab is accessible only by authorized administrative service personnel with password access. The [System] tab can only be accessed in Standby mode.

## NOTE

- 
- The System tab is only available in Standby mode.
  - The default System tab password is: 1234. The authorized administrator should change the default password immediately after the system is installed to prevent unauthorized access to the System tab. The password can be maximum of 6 digits in length containing numerals 0 to 9.
- 

## Configure Basic Settings

System Tab Button	Choices		Description
Calibrate	External AG Module/CO <sub>2</sub> Module		Select to calibrate the External AG Module/CO <sub>2</sub> Module, Internal AG Module or O <sub>2</sub> sensor. Follow the screen instructions.
	O <sub>2</sub> Sensor		
Language	ENGLISH (default)		Select to set the language of the user interface text.
Default Settings	Default Vent Mode	VCV(default), SIMV-VC, PCV, SIMV-PC, PS	Select to set the default ventilation mode.

Manage Defaults	Save as O.R. Defaults	Select [ <b>Save as O.R. Defaults</b> ] to save the current configuration as the user default configuration.
	Load O.R. Defaults	Select [ <b>Load O.R. Defaults</b> ] to load the user default configuration.
	Restore Partial Defaults	Select [ <b>Restore Partial Defaults</b> ] to overwrite the user defaults and system settings with the factory default settings. Note that network settings will not be restored.
	Import Defaults	Select [ <b>Import Defaults</b> ] to import a copy of the defaults from the USB mass storage device if one has been inserted into an SB port at the rear of the Machine.
	Export Defaults	Select [ <b>Export Defaults</b> ] to export a copy of the defaults to the USB mass storage device if one has been inserted into an SB port at the rear of the machine.
Time Settings	Time Zone (Default =UTC-05:00)	Select to set the UTC time zone offset.
	Daylight Savings (Default=Manual)	Select to set the Daylight Savings Time (DST) to be adjusted automatically by the system, or manually by the authorized administrator. If the region or country of installation does not observe DST, change this setting to [ <b>Manual</b> ]. If [ <b>Daylight Savings</b> ] is set to [ <b>Auto</b> ], the [ <b>On</b> ] / [ <b>Off</b> ] button of [ <b>Daylight Savings Time</b> ] in the [ <b>Date/Time</b> ] dialog becomes inactive and cannot be selected.
	DST Start (Default =First Sunday in April at 2:00 AM)	Select to set the START of Daylight Savings Time. This setting is not available if [ <b>Daylight Savings</b> ] is set to [ <b>Manual</b> ].
	DST End (Default =Last Sunday in October at 3:00 AM)	Select to set the END of Daylight Savings Time. This setting is not available if [ <b>Daylight Savings</b> ] is set to [ <b>Manual</b> ].
Network	See <i>Configure Network</i> .	
Change Password	1234 (default)	Select to change the System tab password. The authorized administrator should change the default password immediately after the

			system is installed to prevent unauthorized access to the System tab. The password can be up to 6 digits in length containing numerals 0 to 9.
Unit	Pressure	cmH <sub>2</sub> O (default)	Select to set the Pressure unit.
		hPa	
		mbar	
	CO <sub>2</sub>	mmHg (default)	Select to set the CO <sub>2</sub> unit.
		kPa	
		%	
Configuration Info	/		Select to display the machine ID and the status of system functions.
Export Data	/		Select to export animal data via mass storage device.
Other Settings	Standby Settings	On(default)	When turned on, Spirometry Reference loops will be deleted upon discharge. When turned off, Spirometry Reference loops will not be deleted upon discharge.
		Off	
	Clear History	On	When turned on, all Trends and Event Logs will be deleted upon exiting Standby.
		Off (default)	When turned off, all Trends and Event Logs will not be deleted upon exiting Standby.
	O <sub>2</sub> Cell Monitoring	On (default)	Select to enable or disable O <sub>2</sub> cell monitoring.
		Off	

## Configure Network Settings

Network configuration settings can be set via the [Network] button:

Select  key → [System] tab → [Network] button.

Settings	Parameters
Configure Ethernet	Enter: <b>IP Address</b> (default = 192.168.23.250) <b>Subnet</b> (default =255.255.255.0) Default Gateway (default = [blank])
Configure Serial	Select: <b>Protocol</b> (None, HL7, MR-WATO (default), Philips) <b>Baud Rate</b> (57600 (default), 11520) <b>Data Bits</b> (8 (default), 7, 6, 5) <b>Stop Bits</b> (1 (default), 2) <b>Parity</b> (Odd, Even, <b>None</b> (default)) <b>Interval</b> : Disabled when Protocol=None: <b>Off</b> (default); Enabled when Protocol=HL7:10 Sec, 30 Sec, <b>1 Min</b> (default), 5 Min, 30 Min, 1 Hour, 2 Hour, 6 Hour, 12 Hour, 24 Hour.
Network Protocol	
HL7	Select: <b>On</b> , <b>Off</b> (default)
<b>Interval</b> (enabled when HL7 = On)	Select: 10 Sec, 30 Sec, <b>1 Min</b> (default), 5 Min, 30 Min, 1 Hour, 2 Hour, 6 Hour, 12 Hour, 24 Hour
<b>Destination IP</b> (enabled when HL7 = On)	Enter: Destination IP (default = <b>192.168.23.200</b> )
<b>Port</b> (enabled when HL7 = On)	Enter: Port (default = <b>1550</b> )
Set HL7 Compatibility	Select: Most Recent (default), 04.00.00 to 04.05.02.00
SNTP Protocol	
Interval	Select: <b>Off</b> (default), 10 Sec, 30 Sec, 1 Min, 5 Min, 30 Min, 1 Hour, 2 Hour, 6 Hour, 12 Hour, 24 Hour
Primary Server IP	Enter: Primary Server IP (default = <b>132.163.4.103</b> )
Secondary Server IP	Enter: Secondary Server IP (default = <b>210.72.145.44</b> )

---

### 3.2.2.5 Service Tab

Accessible only by Mindray-authorized service personnel. Please contact Mindray Technical Support for assistance.



## NOTE

- 
- **The [Service] tab is for use only by Mindray Technical Service. Please contact Mindray Technical Support for details.**
- 

### 3.2.3 Alarm Key

Select the  key on the main screen to open the [**Alarms**] menu to set alarm limits, set alarm volume, and view all active alarms.

### 3.2.4 Audio Pause Key

Select  key to pause all currently sounding alarm tones for 120 s. The alarm audio pause icon and countdown timer for 120 s display on the top of the screen. Select again to resume the alarm audio. Note, however, the alarm will sound if a new alarm occurs while the system is in an audio-paused state. If this occurs, you can select the  key again to pause the new alarm audio and reset the countdown timer to 120 s.

---

**FOR YOUR NOTES**

# 4 Operations and Ventilation Setup

## WARNING

- Before using this anesthesia machine on the animal, ensure that the system is correctly connected and in good condition, and that all the tests described in 6 Preoperative Test are already completed. In case of test failure, do not use the system. Have a qualified service representative repair the system.





## 4.1 Turn on the System

When the system is powered on, it performs a self-test to ensure its alarm system (alarm LED, speaker, and buzzer) and hardware (flowmeter board, ventilator board, assistant ventilator board, power board, and CPU board) are properly functioning.

To perform a system self-test:

1. Connect the power cord to the AC power source. Ensure that the AC power LED is illuminated.
2. Set the system switch to .
3. The system powers up and begins its system self-test. The system self-test Items are as follows:

System Self-test Items	Description	Comments
1. Power-on Self Test	When the anesthesia machine is powered on, it performs a self-test to ensure its alarm system (alarm LED, speaker, and buzzer) and hardware (ventilator board, assistant ventilator board, power board, and CPU board) are properly functioning.	Power-on self test can not be skipped after the system is powered on. When the indicator of the current self test item is red or yellow, the
2. Preoperative Check List	Display the inspection checklist needed to be performed before operating the system.	system can not skip to other self test items. When the indicator is white,
3. Auto Leak Test	Check if the breathing system leaks in mechanical ventilation mode.	grey or green, the system can skip from the current self test
4. Manual Leak Test	Check if the breathing system has leakage in manual ventilation mode.	item to any other self test items.

System Self-test Indicator	Comments
	Current active self test item.
	The self test item is not performed yet.
	No error. The system passed the current self test item.
	Serious error. The system can not work.
	Partial error. The system can work.

- After the system self-test is completed, the test results are displayed on the screen. Startup alarm messages also may be displayed. For the list of start-up alarm messages, see *D.2.1 Startup Alarm List*.

Bundle Version:

The Bundle Version is displayed in all System Self-Test results. The Bundle Version is the version number of the software package that is installed in the system. If the Bundle Version displays a fail status, contact Mindray Technical Support.

- Proceed to operate or troubleshoot the system based on the self-test results.

---

## **WARNING**

- Do not use the anesthesia machine if it generates alarms during start-up or fails to operate normally. Contact your service personnel or Mindray..**
-



---

## 4.2 Turn off the System

To turn off the system, do as follows:

1. Confirm that system use is finished.

2. Set the system switch to .

- If the power switch is turned off in Standby mode, the system will power off immediately.
- If the power switch is turned off in Manual mode or in any of the Automatic ventilation modes, the system will wait 12 s to power off completely. In the 12-second power off delay period, the screen will display a 10 s countdown timer. If the system is performing Automatic ventilation, the ventilator will continue ventilating the animal in the current ventilation mode.
- A beep is heard for each second of the countdown from 10 to 1 s, after which a two-second shutdown sound is given when the timer reaches zero.
- The volume of power off delay sound can be adjusted in the [System Alerts] setting in the [Alarms] → [Audio] menu.
- When the user turns on the machine during the power off delay period, the countdown timer will disappear, and the ventilator will resume its previous state.



### NOTE

- **The powering off delay function is not implemented during Standby, only when actively ventilating.**
- 

## 4.3 Animal Setup

### 4.3.1 Enter Standby Mode

When the system is in non-standby mode,

- One way to enter Standby (factory default):
  1. Select the  key on the main screen.
  2. Follow the screen prompts to enter Standby mode.
- Another way to enter Standby:
  1. Set the Auto/Manual ventilation switch to Manual.
  2. Select the  key on the main screen.
  3. Follow the screen prompts to enter Standby mode.

---

## NOTE

---

- The system provides two ways to enter or exit Standby mode. If you need to change the way to enter or exit Standby mode, please contact Mindray Technical Support for details.
  - After selecting , you can set whether to restore default settings from the pop-up dialog box.
- 

### 4.3.2 Exit Standby Mode

- One way to exit Standby (factory default):

To exit Standby, touch the waveform area or select the  key on the screen, then follow the screen prompts to exit Standby mode.

- Another way to exit Standby:

1. Set the Auto/Manual ventilation switch to Manual.
2. Touch the waveform area or select the  key on the screen, then follow the screen prompts to exit Standby mode.

## NOTE

---

- The system provides two ways to enter or exit Standby mode. If you need to change the way to enter or exit Standby mode, please contact Mindray Technical Support for details.
  - **To exit Standby by turning on the fresh gas flow, the flow must be increased to more than 0.2 L/min.**
-

---

## 4.4 Input Fresh Gas

### 4.4.1 Set O<sub>2</sub>, N<sub>2</sub>O and Air Inputs

1. Connect the gas supplies correctly and ensure adequate gas pressure.
2. You can control the O<sub>2</sub>, N<sub>2</sub>O and Air flows in the fresh gas through the O<sub>2</sub>, N<sub>2</sub>O and Air flow controls. Readings of the gas flow can be seen on the glass tube above the flow control knob.

The O<sub>2</sub> and N<sub>2</sub>O flow controls constitute a chain linkage:

- ◆ Turn the N<sub>2</sub>O flow control counterclockwise to increase the N<sub>2</sub>O flow to some extent. Then continuing turning the N<sub>2</sub>O flow control will cause the O<sub>2</sub> flow control to turn counterclockwise together to increase the O<sub>2</sub> flow, keeping the O<sub>2</sub> concentration in the mixed gas above 25%.
- ◆ Turn the O<sub>2</sub> flow control clockwise to decrease the O<sub>2</sub> flow to some extent. Then continuing turning the O<sub>2</sub> flow control will cause the N<sub>2</sub>O flow control to turn clockwise together to decrease the N<sub>2</sub>O flow, keeping the O<sub>2</sub> concentration in the mixed gas above 25%.

### NOTE

- 
- **This anesthesia machine can be used alone as a ventilator. You can adjust O<sub>2</sub> concentration in the breathing system through the O<sub>2</sub> flow control.**
  - **The O<sub>2</sub> concentration in the fresh gas may be quite different from that in the breathing system.**
  - **When the supply mains is not connected and batteries are deplete, The flow rate and composition of fresh gas are not affected.**
  - **When the individual N<sub>2</sub>O and Air supply fail, the corresponding fresh gas cannot be achieved. When O<sub>2</sub> supply fails, both O<sub>2</sub> and N<sub>2</sub>O fresh gas cannot be achieved.**
-

---

## 4.4.2 Set Anesthetic Agent

### NOTE

---

- You do not need to perform this operation if inspiratory anesthetic agent is not used.
  - This anesthesia machine can be mounted with vaporizers corresponding with Halothane, Enflurane, Isoflurane and Sevoflurane. Only one of the two mounted vaporizers can be opened at a time because the vaporizers are featured with interlock.
- 

### 4.4.2.1 Select the Desired Anesthetic Agent

1. Determine the anesthetic agent to be used and then fill the vaporizer. For details, refer to *11.2.2 Fill the Vaporizer*.
2. Mount the vaporizer filled with anesthetic agent onto the anesthesia machine. For details, refer to *11.2 Install the Vaporizer*.

### NOTE

---

- Install the vaporizers that are compliant to ISO 80601-2-13 on this anesthesia machine. Refer to the manufacturer's vaporizer Instructions For Use for filling or draining the vaporizer and other information.
- 

### WARNING

---

- Ensure that the correct anesthetic agent is used. The vaporizer is designed with the specific anesthetic agent named on it and further indicated by color coded labeling. The concentration of the anesthetic agent actually output will vary if the vaporizer is filled with the wrong agent.
- 

### 4.4.2.2 Adjust the Concentration of Anesthetic Agent

Push the button and turn the concentration control on the vaporizer to set the appropriate concentration of anesthetic agent.

### NOTE

---

- Refer to the vaporizer Operator's Manual for the detailed using of anesthetic agents.
-

---

## 4.5 Set Ventilation Mode

### NOTE

---

- In all ventilation modes, when inspiration pressure reaches the **PEAK High** alarm limit, the system switches to expiration immediately and airway pressure is released.
  - If the **[Set Mode]** or **[Preset Mode]** button is not selected after several seconds, an audio reminder will sound for several seconds and then the system will return to the previous ventilation mode tab.
  - The minimum pressure at the **ANIMAL CONNECTION PORT** generated by the anesthesia ventilator is zero, no negative pressure can be generated on the normal and single fault condition.
  - When the drive gas supply fails, the mechanical ventilation cannot function.
- 

In non-mechanical ventilation mode,

1. Select the tab of the desired ventilation mode. The **[Preset Mode]** button will turn green and flash.
2. Select each available ventilation parameter to edit the parameter setting.
3. Select the **[Preset Mode]** button to confirm changes.

In mechanical ventilation mode,

1. Select the tab of the desired ventilation mode. The **[Set Mode]** button will turn green and flash.
2. Select each available ventilation parameter to edit the parameter setting.
3. Select the **[Set Mode]** button to confirm changes.



### 4.5.1 Monitored Parameters

The system monitors the following ventilation parameters: Expiratory Tidal Volume (Vt), Expiratory Minute Volume (MV), Breath rate (Rate), Airway Pressure (Paw), Positive end-expiratory pressure (PEEP), Ratio of inspiratory time to expiratory time (I:E), Resistance (Raw), Compliance (Compl), O<sub>2</sub> concentration, CO<sub>2</sub> concentration, AA concentration.

---

## 4.5.2 Set Manual Ventilation Mode

Manual ventilation mode is the operating mode used for manually ventilating a animal or to let a animal breathe spontaneously. To use the manual mode, the user must first set the APL valve to the desired pressure value, and then set the Auto/Manual ventilation switch on the breathing module, to enter and exit Manual mode. Push the O<sub>2</sub> flush button to inflate the bag if necessary.

1. Turn the APL valve control to adjust the pressure in the breathing system within the appropriate range.
2. Set the Auto/Manual switch to the  position. The ventilation mode prompt area displays the symbol for manual ventilation mode.
3. Push the O<sub>2</sub> flush button  to inflate the bag if necessary.

In the manual ventilation mode, you can use the APL valve to adjust the breathing system pressure limit and gas volume in the manual bag. When the pressure in the breathing system reaches the pressure limit set for the APL valve, the valve opens to release excess gas.

### NOTE

- 
- **The APL valve adjusts the breathing system pressure limit during manual ventilation. Its scale shows approximate pressure setting.**
-

---

The following illustrations show the Paw waveform and flow waveform in the manual ventilation mode.

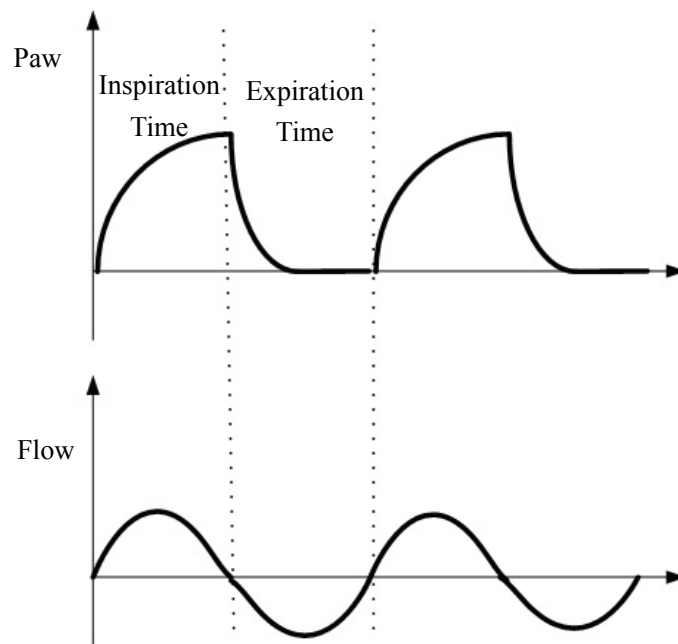

## NOTE

- When using the anesthesia machine on the animal, ensure that manual ventilation mode is available.

---

### 4.5.3 Settings before Starting Mechanical Ventilation Mode

1. Ensure that the system is in Standby mode.
2. Select the tab of the desired ventilation mode.
3. Set the appropriate ventilation parameters in the parameter setup hot keys area.
4. Select the [**Preset Mode**] button (Green and flash) to confirm changes.
5. Check the ACGO switch to ensure that it is OFF.
6. Set the Auto/Manual switch to the  position.
7. If necessary, push the O<sub>2</sub> flush button **O<sub>2</sub>+** to inflate the bellows.

---

## NOTE

---

- **The default mechanical ventilation mode of the anesthesia machine is VCV. Other mechanical ventilation modes are optional.**
  - **When mechanical ventilation mode is switched, for example, switching from VCV mode to PSV mode, the [Set Mode] or [Preset Mode] button in PSV mode will flash indicating the pending mode and parameters needs confirmation or modification.**
- 

### 4.5.4 Volume Control Ventilation (VCV)

#### 4.5.4.1 Description

Volume control ventilation (hereinafter referred to as VCV) mode is a fully-mechanical ventilation mode. In the VCV mode, each time mechanical ventilation starts, gas is delivered to the animal at a constant flow, which reaches the preset  $V_t$  within the gas delivery time. To ensure a certain amount of  $V_t$ , the resulted airway pressure ( $P_{aw}$ ) changes based on animal pulmonary compliance and airway resistance. Within the gas delivery time, the flow remains constant as long as the airway pressure is less than  $P_{limit}$  and the pressure remains constant if the pressure reaches  $P_{limit}$ .

In the VCV mode, you can set  $P_{limit}$  to prevent high airway pressure from injuring the animal. In this mode, you can adjust  $T_{pause}$  to improve animal pulmonary gas distribution, and adjust PEEP to improve expiration of end-tidal carbon dioxide and to increase oxygenation of breathing process.

To ensure the set tidal volume gas delivery, the ventilator adjusts gas flow based on the measured inspiratory volume, dynamically compensates for the loss of tidal volume arising from breathing system compliance and system leakage, and compensates for the effect of fresh gas as well. This is called tidal volume compensation.

In the VCV mode, if tidal volume compensation has failed, the system can continue delivering gas stably but cannot compensate for the effects of fresh gas flow and breathing system compliance losses.



---

#### 4.5.4.2 Waveforms

The following illustrations show the Paw waveform and flow waveform in the VCV mode.

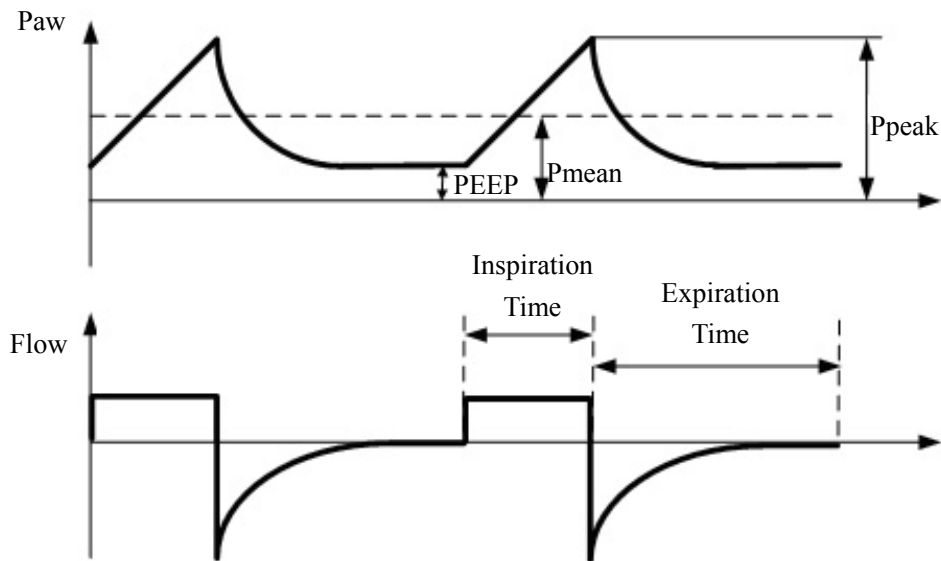

Generally, in the VCV mode, the flow waveform is at a constant flow during inspiration and the Paw waveform rises in the same period.

#### 4.5.4.3 Start VCV Mode

1. Select the [VCV] tab on the main screen.
2. Check that all VCV parameters are set appropriately.  
If necessary, select the parameter softkey to edit the parameters settings.
3. Select the [Set Mode] button to confirm change.

#### NOTE

- Before activating a new mechanical ventilation mode, ensure that all related parameters are set appropriately.
-

---

#### 4.5.4.4 Parameter Setup Hot Keys Area in VCV Mode

When selection of VCV mode is confirmed, the parameter setup hot keys area at the bottom of the screen is automatically switched over to the parameter setup area for this mode. The following illustration shows all related parameters to be set in VCV mode.



1. [Vt]: Tidal volume
2. [Rate]: Breath rate
3. [I:E]: Ratio of inspiratory time to expiratory time
4. [Tpause]: Percentage of inspiratory plateau time in inspiratory time
5. [PEEP]: Positive end-expiratory pressure
6. [Plimit]: Pressure limit level

#### 4.5.4.5 Set Parameters in VCV Mode

You can use the quick keys and control knob to set the parameters in VCV mode. The following takes setting of [Vt] as an example.

1. Select the [Vt] hot key.
2. Push the control knob and turn it to set [Vt] to the appropriate value.
3. Push the control knob or ventilator parameter setup quick key to confirm the setting.
4. Set other parameters in this mode in the similar way.

#### NOTE

- 
- If the parameter value is adjusted outside the range, the relevant prompt message is displayed in the system prompt message area.
  - Confirm the adjustment of one parameter before adjusting another parameter. If you want to restore the value before adjustment, you have to reset the parameter value.
-

---

## 4.5.5 Pressure Control Ventilation

### 4.5.5.1 Description

Pressure Control Ventilation (hereinafter referred to as PCV) mode is a basic fully-mechanical ventilation mode. In the PCV mode, each time mechanical ventilation starts,  $P_{aw}$  rises rapidly to the preset  $P_{insp}$  (pressure control level). Then gas flow slows down through the feedback system to keep  $P_{aw}$  constant until expiration starts at the end of inspiration. The tidal volume delivered in the PCV mode changes based on animal pulmonary compliance and airway resistance.

In the PCV mode, you can also select to set PEEP to improve expiration of end-tidal carbon dioxide and to increase oxygenation of breathing process.

### 4.5.5.2 Waveforms

The following illustrations show the  $P_{aw}$  waveform and flow waveform in the PCV mode.

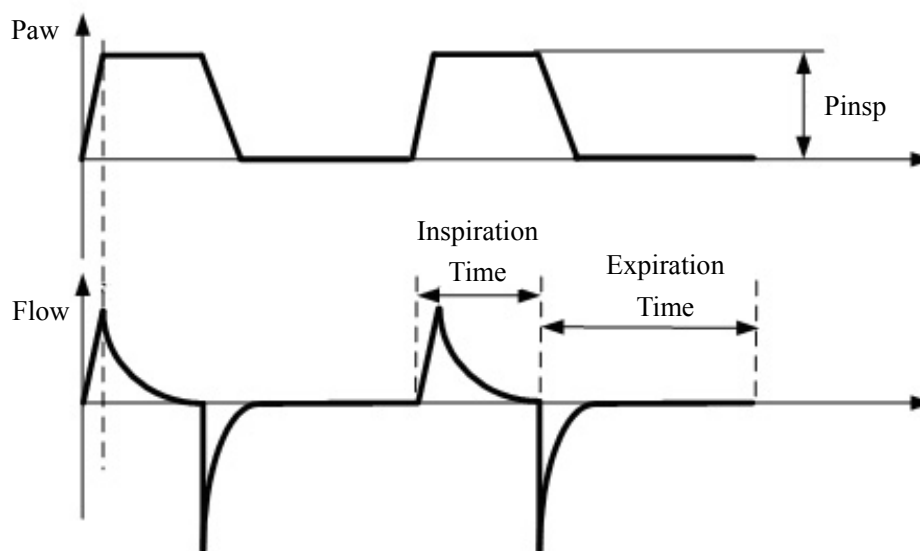

Generally, in the PCV mode, the  $P_{aw}$  waveform rises sharply during inspiration and stays at the plateau for a relatively long time without peak. The flow waveform decelerates in the same period.

In the PCV mode, tidal volume is measured instead of preset.

### 4.5.5.3 Start Pressure Control Ventilation Mode

To start [PCV], do as follows:

1. Select the [PCV] tab on the Main Screen.
2. Check that all PCV parameters are set appropriately.

If necessary, select the parameter softkey to edit the parameters settings.

3. Select the [Set Mode] button to confirm change.

---

#### 4.5.5.4 Parameter Setup Hot Keys Area in Pressure Control Ventilation Mode

When selection of [PCV] mode is confirmed, the parameter setup hot keys area at the bottom of the screen is automatically switched over to the parameter setup area for this mode. The following illustration shows all related parameters to be set in PCV mode.



1. [PInsp]: Pressure control level of inspiration
2. [Rate]: Breath rate
3. [I:E]: Ratio of inspiratory time to expiratory time
4. [Tslope]: Time for the pressure to rise to target pressure
5. [PEEP]: Positive end-expiratory pressure

#### 4.5.5.5 Set Parameters in Pressure Control Ventilation Mode

You can use the quick keys and control knob to set the parameters in PCV mode. The following takes setting of [PInsp] as an example.

1. Select the [PInsp] hot key.
2. Push the control knob and turn it to set [PInsp] to the appropriate value.
3. Push the control knob or ventilator parameter setup quick key to confirm the setting.
4. Set other parameters in this mode in the similar way.

#### NOTE

- 
- If the parameter value is adjusted outside the range, the relevant prompt message is displayed in the system prompt message area.
  - Confirm the adjustment of one parameter before adjusting another parameter. If you want to restore the value before adjustment, you have to reset the parameter value.
-

---

## 4.5.6 Synchronized Intermittent Mandatory Ventilation (SIMV)

This anesthesia machine supports two modes of SIMV: SIMV-Volume Control (SIMV-VC) and SIMV-Pressure Control (SIMV-PC).

### 4.5.6.1 Description

#### ■ SIMV-VC

SIMV-VC means to deliver volume controlled ventilation to the animal by phase at the preset interval. In the SIMV-VC mode, the ventilator waits for animal's next inspiration based on the specified time interval. The sensitivity depends on [**Trigger**] (optional flow and pressure). Higher the value of Trigger parameter is (either for Flow or Pressure range), more effort from animal is required to initiate a breath. If [**Trigger**] is reached within the trigger waiting time (called synchronous [**Trigger Window**]), the ventilator delivers volume controlled ventilation synchronously with the preset tidal volume and inspiratory time. If the animal does not inspire within the [**Trigger Window**], the ventilator delivers volume controlled breath to the animal at the end of [**Trigger Window**]. Spontaneous breathing outside [**Trigger Window**] will acquire pressure support breaths.

#### ■ SIMV-PC

SIMV-PC means to deliver pressure controlled ventilation to the animal by phase at the preset interval. In the SIMV-PC mode, the ventilator waits for animal's next inspiration based on the specified time interval. The sensitivity depends on [**Trigger**] (optional flow and pressure). If [**Trigger**] is reached within the trigger waiting time (called synchronous [**Trigger Window**]), the ventilator delivers pressure controlled ventilation synchronously with the preset pressure control level and inspiratory time. If the animal does not inspire within the [**Trigger Window**], the ventilator delivers pressure controlled breath to the animal at the end of [**Trigger Window**]. Spontaneous breathing outside [**Trigger Window**] will acquire pressure support breaths.

### 4.5.6.2 Waveforms

- SIMV-VC

The following illustrations show the Paw and flow waveforms in the SIMV-VC mode.

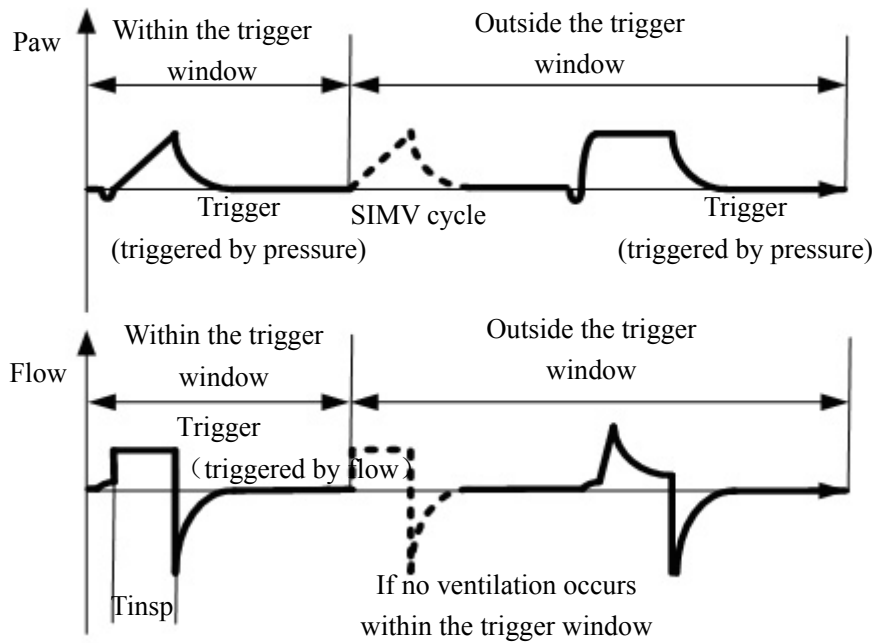

**【SIMV-VC】 + 【PSV】**

- SIMV-PC

The following illustrations show the Paw and flow waveform in the SIMV-PC mode.

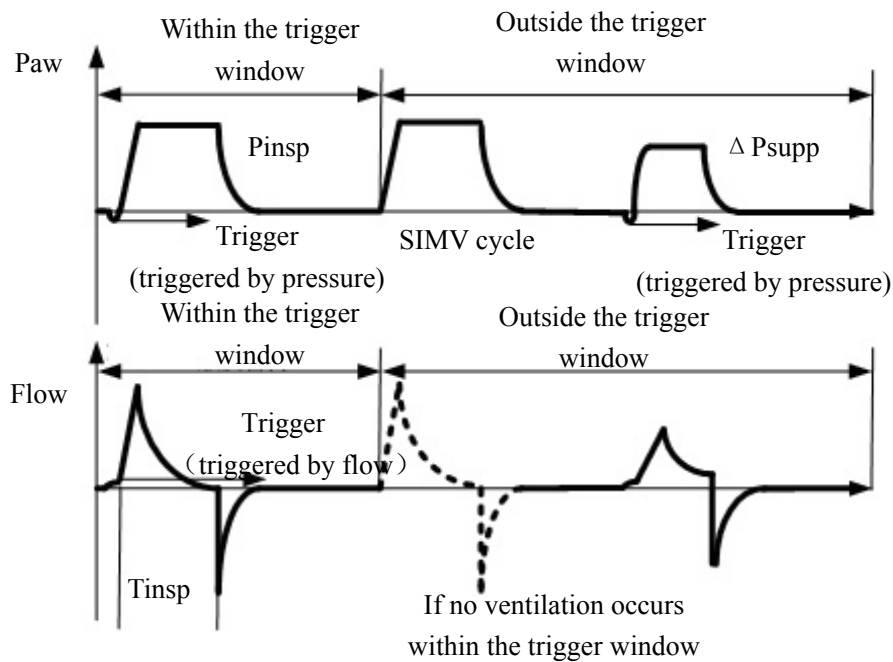

**【SIMV-PC】 + 【PSV】**

---

### 4.5.6.3 Start SIMV Mode

You can select [SIMV-VC] or [SIMV-PC] as required.

To start SIMV-VC or SIMV-PC, do as follows:

1. Select the [SIMV-VC] tab or [SIMV-PC] tab on the **Main Screen**.
2. Check that all [SIMV-VC] or [SIMV-PC] parameters are set appropriately. If necessary, select the parameter softkey to edit the parameters settings
3. Select the [Set Mode] button to confirm changes.

### 4.5.6.4 Parameter Setup Hot Keys Area in SIMV Mode

When selection of SIMV mode is confirmed, the parameter setup hot keys area at the bottom of the screen is automatically switched over to the parameter setup area for this mode. The specific parameters vary depending on SMIV modes, namely, SIMV-VC, SIMV-PC.

- Parameter setup hot keys in SIMV-VC mode



1. [Vt]: Tidal volume
2. [Rate]: Breath rate
3. [Tinsp]: Time of inspiration
4. [F-Trig]: Flow trigger level. Switch to [P-Trig] if it is set to negative value.
5. [Δ Psupp]: Pressure support level
6. [PEEP]: Positive end-expiratory pressure
7. [Plimit]: Pressure limit level
8. [Tpause]: Inspiratory pause
9. [Trig Window]: Trigger window
10. [Tslope]: Rise time
11. [Exp%]: Expiration trigger sensitivity

- Parameter setup hot keys in SIMV-PC mode



1. [PInsp]: Pressure control level of inspiration
2. [Rate]: Breath rate
3. [TInsp]: Time of inspiration
4. [F-Trig]: Flow trigger level. Switch to [P-Trig] if it is set to negative value.
5. [Tslope]: Rise time
6. [ΔPsupp]: Pressure support level
7. [PEEP]: Positive end-expiratory pressure
8. [Trig Window]: Trigger window
9. [Exp%]: Expiration trigger sensitivity

## NOTE

- When SIMV mode, either SIMV-VC or SIMV-PC, is selected, Pressure Support ventilation mode is used for triggered breaths outside the trigger window. Therefore, you also need to set the parameters in PSV mode appropriately, [ΔPsupp], [Tslope] and [Exp%].

### 4.5.6.5 Set Parameters in SIMV Mode

Similar to setting the parameters in VCV and PCV modes, you can use the quick keys and control knob to set the parameters in SIMV mode. The following takes setting of [Vt] as an example.

1. Select the [Vt] hot key.
2. Push the control knob and turn it to set [Vt] to the appropriate value.
3. Push the control knob or ventilator parameter setup quick key to confirm the setting.
4. Set other parameters in this mode in the similar way.



---

## NOTE

---

- **If the parameter value is adjusted outside the range, the relevant prompt message is displayed in the system prompt message area.**
  - **Confirm the adjustment of one parameter before adjusting another parameter. If you want to restore the value before adjustment, you have to reset the parameter value.**
- 

### 4.5.7 Pressure Support Ventilation

This anesthesia machine supports Pressure Support ventilation.

#### 4.5.7.1 Description

Pressure support ventilation (hereinafter referred to as PS) mode is an auxiliary breathing mode which needs animal's spontaneous breathing to trigger mechanical ventilation. When the animal's spontaneous inspiration reaches the preset trigger level, the ventilator calculates the flow based on  $\Delta P_{supp}$  and  $T_{slope}$  and begins to deliver gas to make  $P_{aw}$  rise to the preset pressure support level rapidly. After that, the ventilator slows down the flow through the feedback system to keep  $P_{aw}$  constant. When the inspiration flow drops to the preset  $Exp\%$  level, the ventilator stops delivering gas and opens expiratory valve, allowing animal to exhale, and waits for next inspiration trigger. Counting from the current inspiration trigger, if inspiration is not triggered within the time for backup mode activation ("60/Min Rate" sec, in which, Min Rate is the minimum breath frequency), the system delivers Apnea PCV ventilation forcibly.

In the PS mode, you do not need to set  $V_t$ .  $V_t$  depends on the animal's inspiratory force and pressure support level, compliance and resistance of the animal and of the whole system. The PS mode is used only when the animal has a reliable breathing drive because breathing must be fully triggered by the animal during ventilation.

The PS mode can be used as part of SIMV-VC or SIMV-PC.

---

### 4.5.7.2 Waveforms

The following illustrations show the Paw waveform and flow waveform in the Pressure Support ventilation mode.

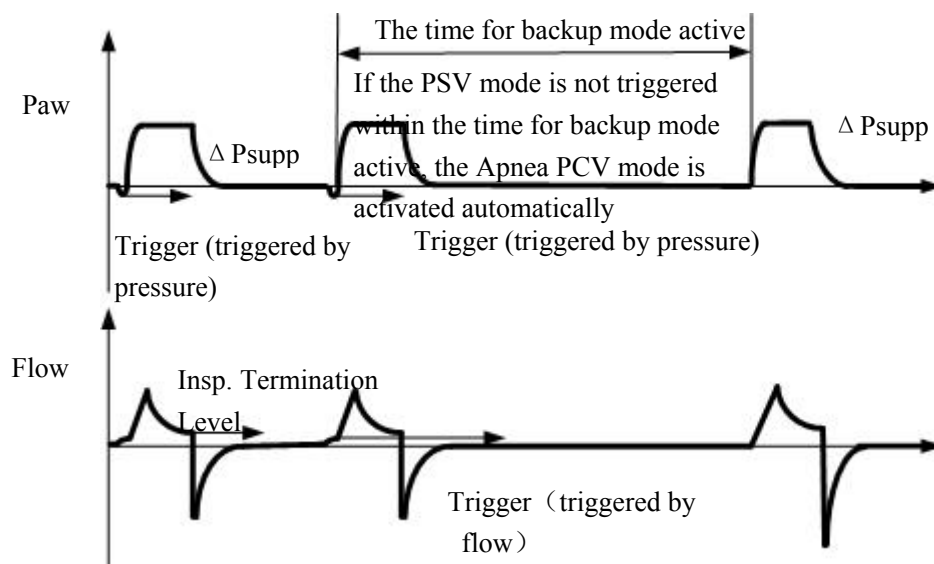

### 4.5.7.3 Start Pressure Support Ventilation Mode

To start PS, do as follows:

1. Select the [PS] tab on the Main Screen.
2. Set [ $\Delta P_{supp}$ ] appropriately.

#### NOTE

- Before activating a new mechanical ventilation mode, ensure that all related parameters are set appropriately.
-

---

#### 4.5.7.4 Parameter Setup Hot Keys Area in Pressure Support Ventilation Mode

When selection of Pressure Support ventilation mode is confirmed, the parameter setup hot keys area at the bottom of the screen is automatically switched over to the parameter setup area for this mode. The following illustration shows all related parameters to be set in PS and CPAP/PS mode.

Parameter setup hot keys in PS mode



1. [**ΔPsupp**]: Pressure support level
2. [**Tslope**]: Time for the pressure to rise to target pressure
3. [**F-Trig**]: Trigger sensitivity. Switch to [**P-Trig**] if it is set to negative value.
4. [**Exp%**]: Expiration trigger level
5. [**Min Rate**]: Minimum breath frequency
6. [**ΔP apnea**]: Apnea pressure
7. [**Apnea I:E**]: Apnea ratio of inspiratory time to expiratory time
8. [**PEEP**]: Positive end-expiratory pressure

#### 4.5.7.5 Set Parameters in Pressure Support Ventilation Mode

You can use the quick keys and control knob to set the parameters in PSV mode. The following takes setting of [**ΔPsupp**] as an example.

1. Select the [**ΔPsupp**] hot key.
2. Push the control knob and turn it to set [**ΔPsupp**] to the appropriate value.
3. Push the control knob or ventilator parameter setup quick key to confirm the setting.
4. Set other parameters in this mode in the similar way.

#### NOTE

- 
- If the parameter value is adjusted outside the range, the relevant prompt message is displayed in the system prompt message area.
  - Confirm the adjustment of one parameter before adjusting another parameter. If you want to restore the value before adjustment, you have to reset the parameter value.
-

---

## 4.5.8 Auxiliary Common Gas Outlet (ACGO)

System enters and exits ACGO mode by turning ACGO switch on and off, if the system is configured with the ACGO switch.

The current vent mode area shall display **[ACGO ON]** when ACGO switch is **[On]**.

---

### **WARNING**

- **When ACGO is On, the automatic ventilation stops.**

---

When ACGO is **[On]**, the system is in ACGO mode. When ACGO is **[Off]**, the system is in Return-from-ACGO mode. For example, if the current ventilation mode is VCV, and then ACGO is set to **[On]**, the system enters ACGO mode. In this case, Return-from-ACGO mode is VCV. When you want to select another ventilation mode, for example, PCV, you can press **[PCV]** and then press the **[Preset Mode]** button to set PCV to Return-from-ACGO mode.

If the current system is in **[Standby]** or **[Manual]** mode, the system enters ACGO mode when ACGO is set to **[On]**. But in this case, you cannot change Return-from-ACGO mode by pressing the **[Preset Mode]** button. Return-from-ACGO mode is **[Standby]** or **[Manual]** mode respectively.

## 4.5.9 Monitor

Monitor mode is only available in the **[Manual]** ventilation mode when there is an AG module or CO<sub>2</sub> module connected to the system

Enter the **[Monitor]** mode by setting the **[Monitor]** button in **[Manual]** mode to **[On]**.

The current vent mode area shall display **[Monitor]** when **[Monitor]** is **[On]**.

---

### **WARNING**

- **When Monitor mode is On, the fresh gas is turned off, the [Alarms] button is disabled and set to Off, the physiological alarms is disabled except the alarms related to CO<sub>2</sub> module and O<sub>2</sub> monitoring.**
-

---

## 4.5.10 Bypass

Bypass mode is only available in the [Manual] ventilation mode when the system is configured with Bypass.

Enter the [Bypass] mode by setting the [Bypass] button in [Manual] mode to [On].

The current vent mode area shall display [Bypass] when [Bypass] is [On].

---

### WARNING



- When Bypass mode is On, the [Alarms] button is disabled and set to Off, the physiological alarms is disabled except the alarms related to CO<sub>2</sub> module, O<sub>2</sub> monitoring and airway pressure.
- 

## 4.6 Start Mechanical Ventilation

### NOTE

- Before starting a new mechanical ventilation mode, ensure that all related parameters are set appropriately.
  - For the first mechanical ventilation of each animal, if the mechanical ventilation parameters are set inappropriately, do not exit Standby mode. Adjust fresh gas and anesthetic gas concentration (if necessary) on the standby screen and set the relevant parameters appropriately based on the animal's condition before starting mechanical ventilation.
- 

To start mechanical ventilation from Standby mode:

1. Set the Auto/Manual ventilation switch to .
2. Exit [Standby] by touching the main screen or by selecting  key.
3. Set the Auto/Manual ventilation switch to . The system will begin mechanical ventilation.

---

## 4.7 Stop Mechanical Ventilation

To stop mechanical ventilation, do as follows:

1. Ensure that the breathing system is set up and the APL valve is set properly before stopping mechanical ventilation.
2. The APL valve adjusts the breathing system pressure limit during manual ventilation. Its scale shows approximate pressure.
3. Set the Auto/Manual ventilation switch to  position. This selects manual ventilation and stops mechanical ventilation (ventilator).

Or, select  key, confirm if you want to restore default settings to enter Standby mode.

# 5 Parameter Monitoring

---

---

## 5.1 General Description

The system displays waveforms and spirometry loops in the waveform area and relevant parameter monitored values in the monitored parameter area.

The monitored parameters are separated into three groups: pressure, volume and gas (available with the AG module or CO<sub>2</sub> module) or FiO<sub>2</sub> (available without the AG module).

## 5.2 Pressure Monitoring

### 5.2.1 Display Pressure Parameters

The **Pressure** parameter group consists of 4 parameters:

- Airway Peak Pressure (PEAK)
- Plateau Pressure (PLAT) or Mean Pressure (MEAN)
- Positive End Expiratory Pressure (PEEP)
- Ratio of inspiratory time to expiratory time (I:E)

If the parameter data is out of range, it is displayed as ---.

### NOTE

- 
- The high alarm limit for Airway Peak Pressure (PEAK) is displayed to the top right of the reading. The low alarm limit for Airway Peak Pressure (PEAK) is displayed to the bottom right of the reading.
  - The display of either Plateau Pressure (PLAT) or Mean Pressure (MEAN) is configured from the [System] tab.
-

---

## 5.2.2 Display Paw Waveform

The associated Pressure vs. Time and Flow vs. Time waveforms are displayed together in the waveform area.

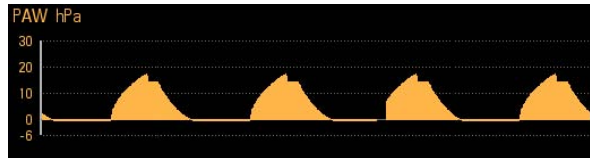

The Y-axis of the Pressure vs. Time waveform is labeled **Paw** (which represents **Airway Pressure**). The unit of measure is **cmH<sub>2</sub>O**, **hPa**, or **mbar**. The Y-axis can automatically adjust the scales.

## 5.2.3 Auto-zero the Pressure Sensors

The system auto-zeros the pressure sensors at regular intervals to compensate for changes in temperature and/or barometric pressure that could affect both pressure and flow measurements. This may affect the waveforms on the screen, but does not affect the volume/pressure delivered to the animal.

The auto-zeroing intervals are: startup, 1 mins, 5 mins, 15 mins, 30 mins, and every 60 mins thereafter.

### NOTE

- 
- The system will display the message [Auto-zero in process] during the auto-zeroing intervals.
-



---

## 5.3 Volume Monitoring

### 5.3.1 Display Volume Parameters

The **Volume** parameter group consists of 3 parameters:

- Tidal Volume (Vt Exp)
- Minute Volume (MV)
- Respiratory Rate (Rate)

If the parameter data is out of range, it is displayed as ---.

#### NOTE

- The high alarm limit for Minute Volume (MV) is displayed to the top right of the reading. The low alarm limit for Minute Volume (MV) is displayed to the bottom right of the reading.
- 

### 5.3.2 Display Volume Waveform

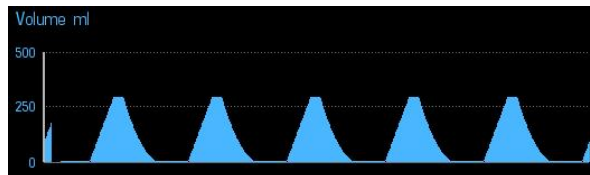

The Y-axis of the Volume vs. Time waveform is labeled **Volume**. The unit of measure is **mL**. The Y-axis can automatically adjust the scales.

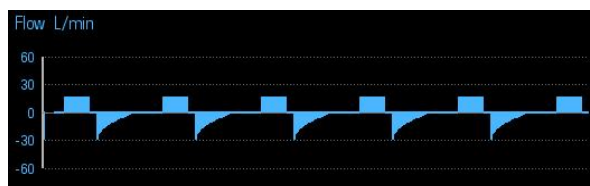

The Y-axis of the Flow vs. Time waveform represents **Flow**. The unit of measure is **L/min**. The Y-axis can automatically adjust the scales.

## 5.4 CO<sub>2</sub> Concentration Monitoring

If your anesthesia machine is configured with CO<sub>2</sub> module, you can monitor FiCO<sub>2</sub> and EtCO<sub>2</sub> by setting up the CO<sub>2</sub> module.

---

## 5.4.1 Display Gas Parameter

The gas monitored parameter group consists of the following parameters (available with the AG module):

- Fraction of inspired carbon dioxide and End-tidal carbon dioxide (FiCO<sub>2</sub> and EtCO<sub>2</sub>)
- Fraction of inspired oxygen and End-tidal oxygen (FiO<sub>2</sub> and EtO<sub>2</sub>)
- Fraction of inspired nitrous oxide and End-tidal nitrous oxide (FiN<sub>2</sub>O and EtN<sub>2</sub>O)
- Fraction of inspired anesthetic agent and End-tidal anesthetic agent (FiAA and EtAA, AA stands for anesthetic agent)
- Minimum alveolar concentration (MAC)
- Age

The gas monitored parameter group consists of the following parameters (available with the CO<sub>2</sub> module):

- Fraction of inspired carbon dioxide and End-tidal carbon dioxide (FiCO<sub>2</sub> and EtCO<sub>2</sub>)
- Breath rate (Rate) (display only when the system is in the ACGO or Monitor mode)

If the parameter data is out of range, it is displayed as ---.

### NOTE

- 
- **The high alarm limit is displayed to the top right of the reading. The low alarm limit is displayed to the bottom right of the reading.**
- 

## 5.4.2 Display Gas Waveform



The Y-axis of the CO<sub>2</sub> vs. Time waveform is labeled CO<sub>2</sub>. The unit of measure is mmHg, kPa, or %. You can adjust the scales of the Y-axis. See *Set Gas Scale (with AG module connected)*.



The Y-axis of the N<sub>2</sub>O vs. Time waveform is labeled N<sub>2</sub>O. The unit of measure is %. You can adjust the scales of the Y-axis. See *Set Gas Scale (with AG module connected)*.

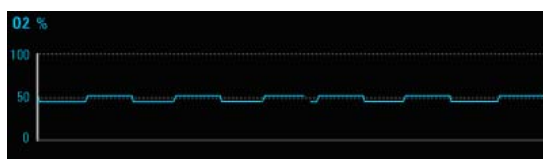

The Y-axis of the O<sub>2</sub> vs. Time waveform is labeled O<sub>2</sub>. The unit of measure is %. You can adjust the scales of the Y-axis. See *Set Gas Scale (with AG module connected)*.



The Y-axis of the AA vs. Time waveform is labeled AA. The unit of measure is %. You can adjust the scales of the Y-axis. See *Set Gas Scale (with AG module connected)*. If no agent is detected, the system displays AA vs. Time waveform. If one anesthetic agent such as Sevoflurane is detected, the system displays Sev vs. Time waveform.

## 5.5 Waveform Autoscaling

If the measured values of Paw, Flow, or Volume are larger than the scale at the end of breath cycle, the system will autoscale the Paw, Flow, or Volume at the beginning of next breath cycle.

If the measured values of Paw, Flow, or Volume are less than the boundary minus a margin at the end of two continuous breath cycles, the system will autoscale the Paw, Flow, or Volume at the beginning of the next breath cycle.

Scale	Margin
Paw	3 cmH <sub>2</sub> O if Paw < 30 cmH <sub>2</sub> O 10 cmH <sub>2</sub> O if Paw ≥ 30 cmH <sub>2</sub> O
Flow	10 L/min if Flow ≤ 30 L/min 15 L/min if Flow > 30 L/min
Volume	25 mL if volume ≤ 100 mL 100 mL if volume > 100 mL

---

## 5.6 Inspired O<sub>2</sub> (FiO<sub>2</sub>)

The unit of measure is % (volume %). If the parameter data is out of range, it is displayed as ---. FiO<sub>2</sub> measurements between 100% and 110% inclusive will be displayed as 100%. Above this range, the system will display ---.

FiO<sub>2</sub> values above 100%, although not realistic, are possible due to errors in calibration.

### NOTE

- 
- **The high alarm limit is displayed to the top right of the reading. The low alarm limit is displayed to the bottom right of the reading.**
- 

## 5.7 Spirometry

There are four parameters:

- Inspired Tidal Volume (Vt Insp)
- Expired Tidal Volume (Vt Exp)
- Resistance (Raw)
- Compliance (Compl)

If the parameter data is out of range, it is displayed as ---.

Spirometry is a respiratory monitoring technology that provides continuous (breath-by-breath) measurement of animal lung mechanics. The resultant pressure, volume, flow, compliance, and resistance data enables quick assessment of the animal's pulmonary status.

The system provides three types of spirometry loops: P-V (Pressure -Volume) loop, F-V (Flow-Volume) loop, and P-F (Pressure-Flow) loop. Data of P-V, F-V, and P-F loops come from pressure, flow and volume data. Only one loop is displayed at a time.

Open the spirometry loop window by selecting the [**Spirometry**] tab.

Currently plotting loop, Reference loop, and Baseline loop can be displayed in Manual and Mechanical Ventilation modes.

Restart the machine will clear Spirometry Loops (Baseline and Reference loops).

Spirometry is disabled in Bypass mode. If Bypass mode is entered when the Spirometry tab is open, then the system will switch to the Waveforms tab.

---

The following illustrations show an F-V loop, a P-V loop and an F-P loop.



The Y-axis of the Flow-Volume Spirometry loop represents **Flow**. The X-axis represents **Volume**.

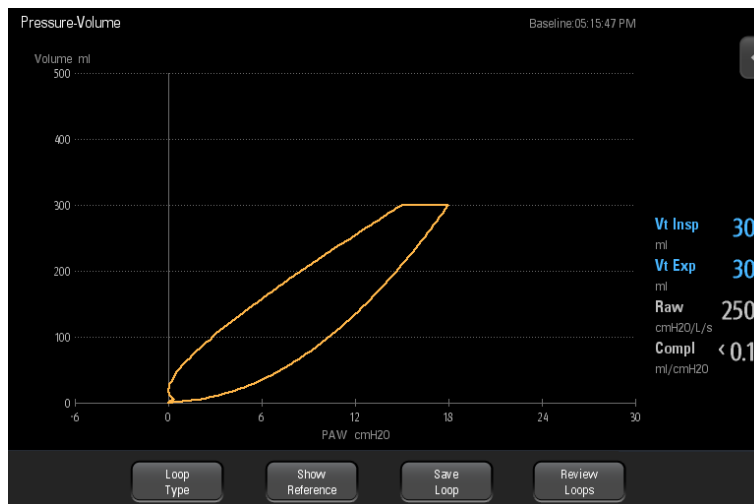

The Y-axis of the Pressure-Volume Spirometry loop represents **Volume**. The X-axis is labeled **Paw** (which represents **Airway Pressure**).

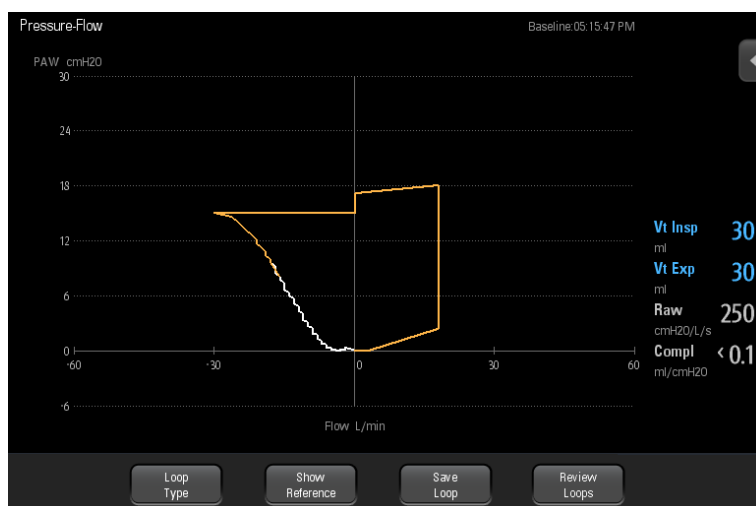

The Y-axis of the Pressure-Flow Spirometry loop represents **Paw** (which represents **Airway Pressure**). The X-axis is labeled **Flow**.

# 6 Preoperative Test

---

---

## 6.1 Preoperative Test Schedules

Perform the preoperative tests listed below at these events:

1. When required after a maintenance or service procedure.
2. Every day before the first animal.
3. Before each animal.

Test Item	Test Intervals
Pipeline tests	Every day before the first animal
Cylinder tests	
Backup oxygen supply tests	
Flow control system tests	
Vaporizer back pressure test	
Inspect the system	Before each animal
Alarm tests	
Power failure alarm test	
Breathing system tests	
Preoperative preparations	
Inspect the AGSS	
Inspect the negative pressure suction device	

### NOTE

---

- Read and understand the operation and maintenance of each component before using the anesthesia machine.
  - Do not use the anesthesia machine if a test failure occurs. Contact us immediately.
  - A checklist of the anesthetic system should be provided including anesthetic gas delivery system, monitoring device, alarm system and protective device which are intended to be used for the anesthetic system, whether they are used alone or assembled together.
-

---

## 6.2 Inspect the System

### NOTE

- 
- **Ensure that the breathing system is correctly connected and not damaged.**
- 

Perform the following inspection checklist before operating the system:

1. The anesthesia machine is correctly connected and undamaged.
2. Inspect the system for:
  - a. Damage to flowmeters, vaporizers, gauges, and supply hoses
  - b. Complete breathing system with adequate Pre-Pak or loose fill CO<sub>2</sub> absorbent
  - c. Correct mounting of cylinders in yokes
  - d. Presence of cylinder wrench
  - e. Auxiliary O<sub>2</sub> supply, available and functioning
3. Check that:
  - a. Flow-control valves are off
  - b. Vaporizers are off
  - c. Vaporizers are filled (not overfilled)
  - d. Filler caps are sealed tightly
  - e. Two vaporizers cannot be turned on at the same time
4. All components are correctly attached.
5. The breathing system is correctly connected, the breathing tubes are undamaged, and the self-inflating manual ventilation device is available and functioning.
6. The gas supplies are connected and the pressures are correct.
7. Cylinder valves are closed on models with cylinder supplies (Verify that the cylinder wrench is attached.).
8. The necessary emergency equipment is available and in good condition.
9. Equipment for airway maintenance and tracheal intubation is available and in good condition.
10. Inspect the color of the absorbent in the canister. Replace the absorbent immediately if obvious color change is detected.



---

---

 **WARNING**

---

- **Check if the gasket is properly installed in place while installing the absorbent canister. If the gasket is not properly installed (for example, gasket is not evenly seated and centered) it may cause breathing system leakage.**
- 
- 

11. Applicable anesthetic and emergency drugs are available.
12. The casters are not damaged or loose and the brake (s) is set and prevents movement.
13. Ensure the breathing system is proper position.
14. The AC mains indicator and the battery indicator are displayed when the power cord is connected to the AC power source. If the indicators are not displayed, the system does not have electrical power.
15. The anesthesia machine is switched on or off normally.

## 6.3 System Self- Test

When the system is powered on, it performs a self-test to ensure its alarm system (alarm LED, speaker, and buzzer) and hardware (flowmeter board, ventilator board, assistant ventilator board, power board, and CPU board) are properly functioning.

1. Turn the power switch on the front panel to the  position. The system powers up and begins its system self-test.

After the system self-test is completed, the test results are displayed on the screen. Startup alarm messages also may be displayed.

2. Proceed to operate or troubleshoot the system based on the self-test results.

---

## 6.4 Leak and Compliance Tests

### 6.4.1 Automatic Circuit Leak and Compliance Test

#### NOTE

---

- The system records the result of the last **Automatic Circuit Leak & Compliance Test** in the [General] tab, including if the test had passed, failed, or was skipped.

To access this information, from the main screen, select the  key →

[General] tab.

- If fresh gas is detected by the system before proceeding with the **Automatic Circuit Leak & Compliance Test**, a [Fresh gas flow detected! Adjust all flowmeters to zero].
  - The result of compliance test will be compensated in mechanical ventilation.
- 

1. Start to test.

- From power up:

If the System is being powered on, the system automatically initiates a self-test and enters the [Automatic Circuit Leak & Compliance Test] screen, followed by the [Manual Circuit Leak Test] screen. If the [Skip] button is selected, the system bypasses the [Automatic Circuit Leak & Compliance Test] and the [Manual Circuit Leak Test] and enters the Standby screen.

- From the main screen:

Select the  key → [General] tab → [Test Leak/Compliance] button.

2. Follow the instructions on the screen:

- (1) Seal the Y-piece.
- (2) Ensure that the sample line port of the breathing circuit is occluded.
- (3) Adjust all flowmeters to zero.

#### NOTE

---

- If ACGO is configured and turn on, “Turn off the ACGO switch” appears.
- 

- (4) Set the Auto/Manual switch to the  position
  - (5) Press the O<sub>2</sub> flush button to completely fill the bellows.
  - (6) Select [Continue] button to proceed with the Automatic Circuit Leak Test.
-

---

## NOTE

---

- The [Continue] button can be selected only when the Auto/Manual switch is set to the  position.
- 

3. Proceed to operate based on the self-test results.

## 6.4.2 Manual Circuit Leak Test

### NOTE

---

- If fresh gas is detected by the system before proceeding with the Manual Circuit Leak Test, a [Fresh gas flow detected! Adjust all flowmeters to zero] message is displayed on the screen.
- 

1. Start to test.

- From power up:

If the System is being powered on, the system automatically initiates a self-test followed by Automatic Circuit Leak and Compliance Test and the Manual Circuit Leak Test. If the [Skip] button is selected, the system bypasses these tests and enters the Standby screen.

- From the main screen:

Select the  key → [General] tab → [Test Leak/Compliance] button.

2. Follow the instructions on the screen:

- (1) Adjust the APL to the 50 cmH<sub>2</sub>O position.
- (2) Adjust all flowmeters to zero.
- (3) Install the Manual Bag.

(4) Set the Auto/Manual switch to the  position.

(5) Press the O<sub>2</sub> flush button until the airway pressure gauge value is between 25 and 35 cmH<sub>2</sub>O.

- (6) Select [Continue] button to proceed with the **Manual Circuit Leak Test**.  
Or, Select [Skip] button to go directly to operational mode.

---



## NOTE

---

- The [Continue] button can be selected only when the Auto/Manual switch is set to the  position.
- 

3. Proceed to operate based on the self-test results.

## 6.5 Power Failure Alarm Test

1. Set the system switch to the  position.
2. Disconnect the AC mains.
3. Ensure that the AC mains indicator and battery charge indicator are extinguished. An audible alarm should sound and the prompt message [**Battery in Use**] should be displayed on the main screen.
4. Reconnect the AC mains.
5. Ensure that an audible alarm should sound and the AC mains indicator and battery charge indicator are illuminated. The prompt message [**Battery in Use**] should not be displayed on the main screen.
6. Set the system switch to the  position.

## 6.6 Pipeline Tests

### NOTE

---

- Do not leave gas cylinder valves open if the pipeline supply is in use. Cylinder supplies could be depleted, leaving an insufficient reserve supply in case of pipeline failure.
-

---

### 6.6.1 O<sub>2</sub> Pipeline Test

1. Connect the O<sub>2</sub> pipeline supply.
2. Close all cylinder valves if the anesthesia machine is equipped with cylinders.
3. Set the system switch to the  position.
4. Set the O<sub>2</sub> flow to 6 L/min.
5. Ensure that O<sub>2</sub> pipeline pressure gauges show 280 to 600 kPa (40 to 87 psi).
6. Disconnect the O<sub>2</sub> supply.
7. As O<sub>2</sub> pressure decreases, alarms for [**O<sub>2</sub> Supply Failure**] and [**Drive Gas Pressure Low**] should occur.
8. Ensure that the O<sub>2</sub> gauge goes to zero.

### 6.6.2 N<sub>2</sub>O Pipeline Test

#### NOTE

- 
- **When doing the N<sub>2</sub>O pipeline test, connect O<sub>2</sub> supply first to enable N<sub>2</sub>O flow control.**
  - **Different from O<sub>2</sub> pipeline supply, when N<sub>2</sub>O supply is disconnected, no alarms related to N<sub>2</sub>O pressure occur as N<sub>2</sub>O pressure decreases.**
  - **Use a safe and approved procedure to collect and remove N<sub>2</sub>O gas.**
- 

1. Connect the O<sub>2</sub> and N<sub>2</sub>O pipeline supplies.
2. Close all cylinder valves if the anesthesia machine is equipped with cylinders.
3. Set the system switch to the  position.
4. Set the O<sub>2</sub> flow to 3L/min.
5. Set the N<sub>2</sub>O flow to 6 L/min.
6. Check that the N<sub>2</sub>O pipeline pressure gauges show 280 to 600 kPa (40 to 87 psi).
7. Disconnect the N<sub>2</sub>O pipeline supply.
8. Ensure that the N<sub>2</sub>O gauge decreases to zero.

---

### 6.6.3 Air Pipeline Test

#### NOTE

- 
- Different from O<sub>2</sub> pipeline supply, when Air supply is disconnected, no alarms related to Air pressure occur as Air pressure decreases.
- 

1. Connect the Air pipeline supply.
2. Close all cylinder valves if the anesthesia machine is equipped with cylinders.
3. Set the system switch to the  position.
4. Set the Air flow to 6 L/min.
5. Check that the Air pipeline pressure gauges show 280 to 600 kPa (40 to 87 psi).
6. Disconnect the Air pipeline supply.
7. Ensure that the Air gauge decreases to zero.

### 6.7 Basic Ventilation Test

1. Attach a breathing circuit and breathing bag.
2. Attach an adult test lung or breathing bag to the animal end of the Y-fitting of the breathing circuit.
3. Set the O<sub>2</sub> flow to 3 L/min and set the N<sub>2</sub>O and Air flow rates to zero flow.
4. Set the ventilator controls to:

Ventilator Controls	Ventilator Settings
Ventilation Mode	PCV
Pressure control level of inspiration - P <sub>insp</sub>	20
Breath rate – Rate	8
I:E Ratio - I:E	1:2
Positive end-expiratory pressure - PEEP	OFF
Time for the pressure to rise to target pressure - T <sub>slope</sub>	0.5

5. Select PCV and begin ventilation.
6. Verify that the breathing bag at the animal end of the Y-fitting of the breathing circuit inflates and deflates and that the PLAT on the display and the airway pressure gauge are consistent with the P<sub>insp</sub> setting.

---

## 6.8 Cylinder Tests

You do not need to perform cylinder tests if the anesthesia machine is not equipped with cylinders.

### 6.8.1 Check the Cylinder Pressure

1. Set the system switch to the  position and connect the cylinders to be checked.
2. Slowly open each cylinder valve using the supplied wrench.
3. Ensure that each cylinder has sufficient pressure. If not, close the applicable cylinder valve and install a full cylinder.
4. Close all cylinder valves.

### 6.8.2 O<sub>2</sub> Cylinder High Pressure Leak Test

1. Set the system switch to the  position and disconnect O<sub>2</sub> pipeline supply.
2. Turn off the O<sub>2</sub> flowmeter.
3. Slowly open the O<sub>2</sub> cylinder valve.
4. Record the current cylinder pressure.
5. Close the O<sub>2</sub> cylinder valve.
6. Record the cylinder pressure after one minute.
7. If the cylinder pressure decreases more than 5000 kPa (725 psi), install a new cylinder gasket. Repeat steps 1 through 6. If the leak continues, do not use the cylinder supply system.

### 6.8.3 N<sub>2</sub>O Cylinder High Pressure Leak Test

1. Set the system switch to the  position and disconnect N<sub>2</sub>O pipeline supply.
2. Turn off the N<sub>2</sub>O flowmeter.
3. Slowly open the N<sub>2</sub>O cylinder valve.
4. Record the current cylinder pressure.
5. Close the N<sub>2</sub>O cylinder valve.
6. Record the cylinder pressure after one minute.

- 
7. If the cylinder pressure decreases more than 700 kPa (100 psi), install a new cylinder gasket. Repeat steps 1 through 6. If the leak continues, do not use the cylinder supply system.

### 6.8.4 Air Cylinder High Pressure Leak Test

1. Set the system switch to the  position and disconnect Air pipeline supply.
2. Turn off the Air flowmeter.
3. Slowly open the Air cylinder valve.
4. Record the current cylinder pressure.
5. Close the Air cylinder valve.
6. Record the cylinder pressure after one minute.
7. If the cylinder pressure decreases more than 5000 kPa (725 psi), install a new cylinder gasket. Repeat steps 1 through 6. If the leak continues, do not use the cylinder supply system.

## 6.9 Backup Oxygen Supply Tests

It is no need to operate this test if the system does not configure with backup oxygen supply.

1. Connect the backup oxygen cylinder to the backup oxygen supply inlet.
2. Set the system switch to .
3. Slowly turn on the valve of the oxygen cylinder.
4. Adjust the flow control knob to control the flow at the middle level within the measure range.
5. Ensure that the value of the oxygen pipeline pressure gauge is within the range of 280 kPa to 600 kPa.
6. Turn off the valve of the oxygen cylinder.
7. As the pressure of oxygen reduces, the **[O<sub>2</sub> Supply Failure]** alarm and **[Drive Gas Pressure Low]** alarm will be triggered.
8. Ensure that the value of the oxygen pipeline pressure gauge is back to zero.



---

## 6.10 Flow Control System Tests

### 6.10.1 Without O<sub>2</sub> Concentration Monitoring

---

#### **WARNING**

---

- Sufficient O<sub>2</sub> in the fresh gas may not prevent hypoxic mixtures in the breathing system.
  - If N<sub>2</sub>O is available and flows through the system during this test, use a safe and approved procedure to collect and remove N<sub>2</sub>O gas.
  - Incorrect gas mixtures can cause animal injury. If the O<sub>2</sub>:N<sub>2</sub>O ratio system does not supply O<sub>2</sub> and N<sub>2</sub>O in the correct proportions, do not use the system.
- 

#### **NOTE**

---

- Slowly open the cylinder valves to avoid damage. Do not use excessive force on the flow controls. After performing the cylinder tests, close all cylinder valves if cylinder supplies are not used.
  - Turn the flow controls slowly. To avoid damaging the control valves, do not turn further when the flowmeter reading is outside the range. When turning a flow control knob clockwise to decrease flow, the flowmeter should reach zero before the knob reaches its most clockwise mechanical stop (Off) position. Do not turn any further when the knob has reached the Off position. Similarly, when turning a flow control knob counterclockwise to increase flow from zero, the flowmeter reading should not indicate a change from zero until the flow control knob is turned approximately one (1) rotation counterclockwise from the Off position, and only if permitted according to the gas ratio control system.
  - N<sub>2</sub>O is cutoff when O<sub>2</sub> supply is less than 100kPa.
  - If power supply failure happens, check the flowmeter to ensure the flow of fresh gas is still available.
  - When the power supply is switched to battery, the flow rate and composition of fresh gas is not affected.
- 

To perform the flow control system tests:

1. Connect the pipeline supplies or slowly open the cylinder valves.
  2. Turn all flow controls fully clockwise (minimum flow).
  3. Set the system switch to the  position.
-

- 
4. Do not use the system if low battery or other ventilator failure alarms occur.
  5. Test the O<sub>2</sub>-N<sub>2</sub>O Link system with flow increasing:

Turn the N<sub>2</sub>O and O<sub>2</sub> flow controls fully clockwise (minimum flow). Then turn the N<sub>2</sub>O flow control counterclockwise and set the N<sub>2</sub>O flow control to the rates shown in the table. The O<sub>2</sub> flow must meet the requirement listed in the following table.

Step	N <sub>2</sub> O flow (L/min)	O <sub>2</sub> flow (L/min)
1	0.9	≥0.3
2	1.5	≥0.5
3	3.0	≥1.0
4	6.0	≥2.0

6. Test the O<sub>2</sub>-N<sub>2</sub>O Link system with flow decreasing:

Turn the N<sub>2</sub>O and O<sub>2</sub> flow controls and set the N<sub>2</sub>O flow to 9.0 L/min and the O<sub>2</sub> flow to above 3 L/min respectively. Then slowly turn the O<sub>2</sub> flow control clockwise and set the N<sub>2</sub>O flow control to the rates shown in the table. The O<sub>2</sub> flow must meet the requirement listed in the following table.

Step	N <sub>2</sub> O flow (L/min)	O <sub>2</sub> flow (L/min)
1	6.0	≥2.0
2	3.0	≥1.0
3	1.5	≥0.5
4	0.9	≥0.3

7. Disconnect the O<sub>2</sub> pipeline supply or close the O<sub>2</sub> cylinder valve.

## NOTE

- **When O<sub>2</sub> supply is disconnected, alarms for [O<sub>2</sub> Supply Failure] and [Drive Gas Pressure Low] occur as O<sub>2</sub> pressure decreases.**

- 
8. Set the system switch to the  position.

---

## 6.10.2 With O<sub>2</sub> Concentration Monitoring

Do as described in **6.13.2 Test the O<sub>2</sub> Concentration Monitoring and Alarms** before testing.

To do the flow control system tests:

1. Connect the pipeline supplies or slowly open the cylinder valves.
2. Turn all flow controls fully clockwise (minimum flow).
3. Set the system switch to the  position.
4. Do not use the system if low battery or other ventilator failure alarms occur.

Steps 5 and 6 are only for systems with N<sub>2</sub>O.

---

### **WARNING**

- **During steps 5 and 6, the O<sub>2</sub> sensor used must be correctly calibrated and the Link system should be kept engaged.**
- **Adjust only the test control (N<sub>2</sub>O in step 5 and O<sub>2</sub> in step 6).**
- **Test the flows in sequence (N<sub>2</sub>O then O<sub>2</sub>).**

- 
5. Test the O<sub>2</sub>-N<sub>2</sub>O Link system with flow increasing:
    - ◆ Turn the N<sub>2</sub>O and O<sub>2</sub> flow controls fully clockwise (minimum flow).
    - ◆ Slowly turn the N<sub>2</sub>O flow control counterclockwise.
    - ◆ Make sure that the O<sub>2</sub> flow increases. The measured O<sub>2</sub> concentration must be  $\geq 25\%$  through the full range.
  6. Test the O<sub>2</sub>-N<sub>2</sub>O Link system with flow decreasing:
    - ◆ Turn the N<sub>2</sub>O flow control and set the N<sub>2</sub>O flow to 9.0 L/min.
    - ◆ Turn the O<sub>2</sub> flow control and set the O<sub>2</sub> flow to 3 L/min or higher.
    - ◆ Slowly turn the O<sub>2</sub> flow control clockwise.
    - ◆ Make sure that the N<sub>2</sub>O flow decreases. The measured O<sub>2</sub> concentration must be  $\geq 25\%$  through the full range.
  7. Disconnect the O<sub>2</sub> pipeline supply or close the O<sub>2</sub> cylinder valve.
  8. Make sure that:
    - ◆ N<sub>2</sub>O and O<sub>2</sub> flows stop. The O<sub>2</sub> flow stops last.
    - ◆ Air flow continues if Air supply is available.
    - ◆ Gas supply alarms occur on the ventilator.
  9. Turn all the flow controls fully clockwise (minimum flow).
  10. Reconnect the O<sub>2</sub> pipeline supply or open the O<sub>2</sub> cylinder valve.
  11. Set the system to Standby.

---

## 6.11 Vaporizer Test

---

### **WARNING**

---

- **During the vaporizer test, the anesthetic agent exits from the fresh gas outlet. Use a safe and approved procedure to remove and collect the agent.**
  - **To prevent damage, turn the flow controls fully clockwise (flow OFF) before using the system.**
- 

Before the test, ensure that the vaporizers are correctly installed. For details about vaporizer installation, refer to *11.2 Install the Vaporizer*.

### 6.11.1 Vaporizer Back Pressure Test

1. Connect the O<sub>2</sub> pipeline supply or slowly open the O<sub>2</sub> cylinder valve.
2. Set the O<sub>2</sub> flow to 6 L/min.
3. Ensure that the O<sub>2</sub> flow stays constant.
4. Adjust the vaporizer concentration from 0 to 1%. Ensure that the O<sub>2</sub> flow must not decrease more than 1 L/min through the full range. Otherwise, install a different vaporizer and repeat this step. If the problem persists, the malfunction is in the anesthesia system. Do not use this system.
5. Test each vaporizer as per the steps above.

### NOTE

---

- **Do not perform test on the vaporizer when the concentration control is between “OFF” and the first graduation above “0” (zero) as the amount of anesthetic drug output is very small within this range.**
-

---

## 6.11.2 Vaporizer Leak Test

1. Set the Auto/Manual ventilation switch to .
2. Set the APL valve to the MIN position.
3. Connect one end of the breathing circuit to the bag arm, one end to the inspiratory port and the Y-piece to the test port:



4. Mount and lock the vaporizer onto the vaporizer mount. (Certain vaporizers need to be set to at least 1% for correct testing. See the vaporizer manufacturer's manual for details.)
5. Set the fresh gas flow to 0.2 L/min.
6. Set the APL valve to 75 and verify that the pressure on the airway pressure gauge increases above 30 cmH<sub>2</sub>O within 2 min.
7. Turn off the vaporizer.
8. Repeat Steps 4, 5, 6, and 7 for the other vaporizer.

---

## 6.12 Breathing System Tests

---

### **WARNING**

---

- **Objects in the breathing system can stop gas flow to the animal. This can cause injury or death. Ensure that there are no test plugs or other objects in the breathing system.**
  - **Do not use a test plug that is small enough to fall into the breathing system.**
- 



1. Ensure that the breathing system is correctly connected and not damaged.
2. Ensure that the check valves in the breathing system work correctly:
  - ◆ The inspiratory check valve opens during inspiration and closes at the start of expiration.
  - ◆ The expiratory check valve opens during expiration and closes at the start of inspiration.

### 6.12.1 Bellows Test

1. Select [**Standby**] key to enter Standby mode after confirmation.
2. Set the Auto/Manual switch to .
3. Set all flow controls to off.
4. Close the breathing system at the animal connection by connecting the Y-piece on the breathing circuit to the leak test port.
5. Push the O<sub>2</sub> flush button to expand the bellows to the top of the bellows enclosure.
6. Ensure that the pressure does not increase to more than 15 cmH<sub>2</sub>O on the airway pressure gauge.
7. The bellows should not fall faster than a rate of approximately 300 mL/min. If the leak rate is greater, troubleshoot the source of the leak. If the source of the leak is the bellows, then the bellows must be replaced.

---

## 6.12.2 APL Valve Test





1. Select  key to enter Standby mode.
2. Set Auto/Manual ventilation switch to .
3. Connect the manual bag to the manual bag port.
4. Connect the Y-piece on the breathing circuit to the leak test plug.
5. Turn the APL valve control to 30 cmH<sub>2</sub>O.
6. Push the O<sub>2</sub> flush button to inflate the manual bag.
7. Ensure that the reading on the airway pressure gauge is with the range of 20 cmH<sub>2</sub>O to 40 cmH<sub>2</sub>O.
8. Turn the APL valve control to the fully open position.
9. Set the O<sub>2</sub> flow to 3 L/min. Turn any other gases off.
10. Ensure that the reading on the airway pressure gauge is less than 5 cmH<sub>2</sub>O.
11. Push the O<sub>2</sub> flush button continuously. Ensure that the reading on the airway pressure gauge does not exceed 10 cmH<sub>2</sub>O.
12. Turn the O<sub>2</sub> flow control to off. Ensure that the reading on the airway pressure gauge does not decrease below 0 cmH<sub>2</sub>O.

---

## 6.13 Alarm Tests

Alarms also can be verified by creating an alarm condition and verifying the corresponding alarm indicators are present on the monitor.

### 6.13.1 Prepare for Alarm Tests

1. Connect a test lung or manual bag to the Y-piece of the breathing circuit.
2. Set the Auto/Manual switch to .
3. Set the system switch to the  position.
4. Set the system to Standby mode.
5. Set the ventilator controls as follows:
  - ◆ Ventilation mode: select [VCV].
  - ◆ [Vt]: 500 mL.
  - ◆ [Rate]: 12 bpm.
  - ◆ [I:E]: 1:2.
  - ◆ [Plimit]: 30 cmH<sub>2</sub>O.
  - ◆ [Tpause] :OFF.
  - ◆ [PEEP]: OFF.
  - ◆ [Tpause]: 10%
6. Set the Auto/Manual switch to .
7. Push the O<sub>2</sub> flush control to set the O<sub>2</sub> flow to 0.5 to 1 L/min.
8. Set the Auto/Manual switch to .
9. Push the O<sub>2</sub> flush button to expand the bellows to the top of the bellows enclosure.
10. Ensure that:
  - ◆ The main screen displays the correct data. The measured values should be within the tolerances specified in the specifications.
  - ◆ The bellows inflates and deflates normally during mechanical ventilation.





---

## 6.13.2 Test the O<sub>2</sub> Concentration Monitoring and Alarms

### NOTE



---

- This test is not required if no O<sub>2</sub> sensor is configured.
  - For the anesthesia machine with an installed gas module, disconnect the sample tube from the Y-piece and breathe into it until you see a CO<sub>2</sub> reading on the screen. Then reconnect the sample tube to the Y-piece. This will activate the gas module alarms.
- 

1. Set the Auto/Manual switch to  and exit Standby mode.
2. Remove the O<sub>2</sub> sensor. After three minutes, ensure that the sensor measures approximately 21% O<sub>2</sub> in room air by verifying the FiO<sub>2</sub> value on the main screen.
3. Select the  key and then [**Limits**] tab. Set the FiO<sub>2</sub> low alarm limit to 50%.
4. Ensure that a low O<sub>2</sub> alarm ([**FiO<sub>2</sub> Too Low**]) occurs.
5. Set the FiO<sub>2</sub> low alarm limit back to a value less than the measured O<sub>2</sub> value and ensure that the alarm cancels.
6. Put the O<sub>2</sub> sensor back in the breathing system.
7. Select the  key and then [**Limits**] tab. Set the FiO<sub>2</sub> high alarm limit to 50%.
8. Connect the manual bag to the manual bag port. Push the O<sub>2</sub> flush button to fill the manual bag. Ensure that the sensor measures at least 90% O<sub>2</sub>.
9. Ensure that a high O<sub>2</sub> ([**FiO<sub>2</sub> Too High**]) alarm occurs.
10. Set the FiO<sub>2</sub> high alarm limit to 100% and ensure that the alarm cancels.

---

### 6.13.3 Test the Low Minute Volume (MV) Alarm

1. Set the Auto/Manual ventilation switch to .
2. Set the ventilator controls as follows:
  - ◆ Ventilation mode: select [VCV]
  - ◆ [Vt]: 500 mL
  - ◆ [Rate]: 12 bpm
  - ◆ [I:E]: 1:2
  - ◆ [Tpause]: 10%
  - ◆ [PEEP]: OFF
  - ◆ [Plimit]: 30 cmH<sub>2</sub>O
3. Select the  key and then the [Limits] tab. Set the MV low alarm limit to 8.0 L/min.
4. Ensure that a low MV alarm occurs after approximately 60 s.
5. Select the  key and then the [Limits] tab. Set the MV low alarm limit back to a value less than the measured MV value, and ensure that the alarm cancels.

### 6.13.4 Test the Apnea Alarm



1. Connect the manual bag to the manual bag port.
2. Set the Auto/Manual ventilation switch to .
3. Turn the APL valve control to set the APL valve to 10 cmH<sub>2</sub>O.
4. Inflate using the O<sub>2</sub> flush button and squeeze the manual bag to ensure that a complete breathing cycle occurs on screen.
5. Stop inflating the manual bag and wait for more than 20 s to ensure that the apnea alarm occurs.
6. Inflate and squeeze the manual bag to ensure that the apnea alarm cancels.

---



### 6.13.5 Test the Continuous Airway Pressure Alarm

1. Connect the manual bag to the manual bag port.
2. Turn the O<sub>2</sub> flow control clockwise to set the O<sub>2</sub> flow to Off.
3. Turn the APL valve control to set the APL valve to 30 cmH<sub>2</sub>O position.
4. Set the Auto/Manual ventilation switch to .
5. Connect the Y-piece on the breathing circuit to the leak test port to occlude the animal end of the breathing system.
6. Push the O<sub>2</sub> flush button for approximately 15 s. Ensure that the Continuous Airway Pressure alarm occurs.
7. Disconnect the breathing circuit and ensure that the alarm cancels.
8. Reconnect the breathing circuit.

### 6.13.6 Test the High Paw Alarm

1. Set the Auto/Manual ventilation switch to .
2. Select the  key and then the [Limits] tab.
3. Set the PEAK low alarm limit to 0 cmH<sub>2</sub>O and PEAK high alarm limit to 5 cmH<sub>2</sub>O.
4. Ensure that a high Paw alarm ([Paw Too High]) occurs.
5. Set the PEAK high alarm limit to 40 cmH<sub>2</sub>O.
6. Ensure the high Paw alarm cancels.

### 6.13.7 Test the Low Paw Alarm

1. Set the Auto/Manual ventilation switch to .
2. Select the  key and then the [Limits] tab.
3. Set the Peak low alarm limit to 2 cmH<sub>2</sub>O.
4. Disconnect the test lung or manual bag from the Y-piece of the breathing circuit.
5. Wait for 20 s. View the alarm area and ensure that a low Paw alarm occurs.
6. Connect the test lung or manual bag to the Y-piece of the breathing circuit. If using a manual bag, squeeze the bag to cancel the alarm.

- 
7. Ensure the low Paw alarm cancels.

### 6.13.8 Test the CO<sub>2</sub> Module Alarm

1. Install CO<sub>2</sub> module and then get ready for test, referring to *8.3.1 Prepare to Measure CO<sub>2</sub>*.
2. Select the  key and then **[Limits]** tab.
3. Set the EtCO<sub>2</sub> high alarm limit to be lower than the concentration of the connected standard gas.
4. Ensure that a medium alarm (**[EtCO<sub>2</sub> Too High]**) displayed on the screen.
5. Set the EtCO<sub>2</sub> low alarm limit to be higher than the concentration of the connected standard gas.
6. Ensure that a medium alarm (**[EtCO<sub>2</sub> Too Low]**) displayed on the screen.

### 6.13.9 Test the AG Module Alarm

1. Install AG module and then get ready for test, referring to *9.3 Prepare to Measure AG*.
2. Disconnect the gas sampling tube and connect the tube to the standard gas bag filled with AA (5% CO<sub>2</sub> must be contained). AA stands for any of the four anesthetic agents: Iso (Isoflurane), Enf (Enflurane), Sev (Sevoflurane), or Hal (Halothane).
3. Select the  key and then **[Limits]** tab.
4. Set the EtAA high alarm limit to be lower than the concentration of the standard gas.
5. Ensure that a high EtAA alarm displayed on the screen.
6. Set the EtAA low alarm limit to be higher than the concentration of the standard gas.
7. Ensure that a low EtAA alarm displayed on the screen.

## 6.14 Preoperative Preparations

1. Ensure that the ventilator parameters and alarm limits are set to applicable clinical levels.
2. Ensure that the system is in Standby mode.
3. Ensure that the equipment for airway maintenance, manual ventilation and tracheal intubation, and applicable anesthetic and emergency drugs are available.
4. Set the Auto/Manual ventilation switch to  .

- 
5. Connect the manual bag to the manual bag port.
  6. Turn off all vaporizers.
  7. Turn the APL valve control to the **MIN** position to fully open the APL valve.
  8. Turn all flow controls to set all gas flows to off.
  9. Ensure that the breathing system is correctly connected and not damaged.

---

## **WARNING**

---

- **Before connecting a animal, flush the anesthesia machine with 5 L/min of O<sub>2</sub> for at least two minute. This removes unwanted mixtures and by-products from the system.**
- 

## 6.15 Inspect the AGSS

1. Connect the vacuum hose to the EVAC port or vacuum port of the healthcare facility and turn on the waste gas disposal system. Adjust the position of the float to be between the MIN and MAX lines by turning its flow adjustment knob (counterclockwise increases flow, clockwise decreases flow).
2. Check if the float can rise and exceed the MIN mark. If any blockage, tackiness, or damage occurs to the float, disassemble, clean the filter, and assemble the float again or replace the float.
3. Drain any moisture from the waste gas hose. Reconnect the waste gas hose to the AGSS waste gas port.

## NOTE

---

- **Do not block the AGSS pressure compensation openings during the inspection. If the float cannot rise, the possible reasons are:**
    1. **The float surface is tacky. Turn over the AGSS and check if the float moves up and down freely.**
    2. **The float is rising slowly. The filter may be blocked. Check if the filter is blocked.**
    3. **The waste gas disposal system is not working or the pump rate is less than the minimum flow value of the AGSS specification. Check the waste gas disposal system.**
-

---

## **6.16 Inspect the Negative Pressure Suction Device**

1. Assemble the negative pressure suction device.
2. Occlude the suction tube inlet at the animal end.
3. Turn on the drive gas supply.
4. Set the negative pressure suction switch to ON.
5. Set the swapping switch to REG.
6. Turn the negative pressure adjustment knob to the maximum.
7. Check if the reading on the pressure gauge is greater than -40 kPa.

# 7 User Maintenance

---

---

## WARNING

---

- Do not use a malfunctioning Anesthesia System. Have all repairs and service done by an authorized service representative.
  - Only use lubricants approved for anesthesia or O<sub>2</sub> equipment.
  - Do not use lubricants that contain oil or grease. They can burn or explode in the presence of high O<sub>2</sub> concentrations.
  - Obey infection control and safety procedures. Utilized equipment may contain blood and body fluids.
  - Movable parts and removable components may present a pinch or a crush hazard. Use care when moving or replacing system parts and components.
- 

## NOTE

---

- No repair should ever be attempted by anyone not having experience in the repair of devices of this nature.
  - Replace damaged parts with components manufactured or sold by Mindray. Then test the unit to ensure that it complies with the manufacturer's published specifications.
- 

## 7.1 Maintenance Schedule

The schedules listed below are the minimum frequency based on 2000 h of usage per year. The equipment should be serviced more frequently if used more than this yearly usage. Maintenance should be performed by a trained technician.

## NOTE

---

- During cleaning and setup, inspect the parts and seals for damage. Replace or repair as necessary.
-

Minimum Frequency	Maintenance
Daily	Clean the external surfaces.
Every 72 h	Perform 21% O <sub>2</sub> calibration (O <sub>2</sub> sensor in breathing system). The system will prompt the user for 21% O <sub>2</sub> calibration.
Biweekly	Drain the vaporizers.
Monthly	100% O <sub>2</sub> calibration (breathing system O <sub>2</sub> sensor).
	Clear water built up inside the watertraps of CO <sub>2</sub> module and AG module.
Annually	Periodic maintenance due, to be performed by a trained technician. Gas Bench calibration. Contact Mindray Technical Support for details.
Every three years	Periodic maintenance due, to be performed by a trained technician. Contact Mindray Technical Support for details.
As necessary	Perform 100% O <sub>2</sub> calibration after replacing the O <sub>2</sub> sensor.
	Replace the O <sub>2</sub> sensor if it cannot be calibrated.
	Before installing the cylinder, use a new cylinder gasket on the cylinder yoke.
	Empty the water trap if there is water build-up.
	Replace the soda lime in the canister if soda lime color change is detected. Follow the manufacturer's instructions.
	Replace the O <sub>2</sub> sensor if a great deviation of the measured value by the O <sub>2</sub> sensor occurs and the problem persists after multiple calibrations.
	Replace the flow sensor if the seal for the flow sensor is damaged, the membrane inside the flow sensor is cracked or distorted, or the flow sensor is cracked or distorted.
	Calibrate the flow sensor after re-installing the cleaned or disinfected flow sensor, after replacing with a new flow sensor, or when tidal volume measurement is inaccurate.
	Replace the AGSS transfer tube if it is damaged.
Replace the APL valve if the relief pressure of the APL valve deviates greatly.	

## 7.2 Breathing System Maintenance

When cleaning the breathing system, replace any parts that are visibly cracked, chipped, distorted or worn. For details, refer to *11 Installations and Connections* and *12 Cleaning and Disinfection*.



---

## 7.3 Flow Sensor Calibration

---

### WARNING

---

- Do not perform calibration while the unit is connected to a animal.
- 

### NOTE

---

- During calibration, do not operate the pneumatic parts. Do not move or press the breathing tubes especially.
  - Calibrate the flow sensor after re-installing the cleaned or disinfected flow sensor, after replacing with a new flow sensor, or when tidal volume measurement is inaccurate.
- 

The flow sensor must be calibrated whenever the flow volume is out of specification or after changing the flow sensor.

1. Ensure that the supply gas pressure is normal.
2. Turn off all fresh gas inputs.
3. Set ventilation switch to .
4. Remove the bellows and reinstall the bellows housing.





- 
5. Plug the Y-piece of the breathing circuit into the leak test port to close the breathing system.



6. Remove the water trap.



7. Ensure that the system is in Standby mode. If not, select  key to enter Standby mode after confirmation.
8. Select  key → [General] tab → [Calibrate Flow Sensors] button.
9. Follow the on-screen prompts and select the [Begin] button to start calibrating the flow sensor. The calibration process takes several minutes. The system will display the results of the calibration status when the process is completed.
10. Reinstall the bellows and water trap.
11. Select [Done] button to close the [Calibration] window.
12. Select [Accept] button to close the [Main] window.

## NOTE

- 
- In case of repeated calibration failure, contact Mindray Technical Support.
-

---

## 7.4 O<sub>2</sub> Sensor Calibration

Perform O<sub>2</sub> calibration when the measured value of O<sub>2</sub> concentration has a large deviation from other reference sources or when the O<sub>2</sub> sensor is replaced. If the O<sub>2</sub> sensor is replaced, 21% and 100% O<sub>2</sub> sensor calibration are required.

For continued O<sub>2</sub> sensor accuracy, the system checks for 21% O<sub>2</sub> calibration approximately every 72 h. The system prompts the user for 21% O<sub>2</sub> calibration as follows:

- ◆ When the machine is powered on, if more than 72 h have elapsed since the last successful calibration, the prompt message [**Calibrate O<sub>2</sub> sensor for 21%**] is displayed. The message disappears after successful calibration.
- ◆ If the machine is kept powered on, the prompt message [**Calibrate O<sub>2</sub> sensor for 21%**] is displayed at the next Standby mode after 5 AM after 72 h have elapsed since the last successful calibration.

---

### **WARNING**

- **Do not perform calibration while the unit is connected to a animal.**
- **The O<sub>2</sub> sensor must be calibrated at the same environment pressure at which it will be used to monitor oxygen delivery in the breathing system. Otherwise, the measured value may be outside the accuracy range.**
- **Disassemble the O<sub>2</sub> sensor before calibrating it. Re-install the O<sub>2</sub> sensor after making sure that there is no water build-up in the O<sub>2</sub> sensor and the connection port on the breathing system.**
- **The O<sub>2</sub> calibration is not required if no O<sub>2</sub> sensor is configured or used.**

---

### **NOTE**

- **Perform O<sub>2</sub> calibration when the measured value of O<sub>2</sub> concentration has a great deviation or when the O<sub>2</sub> sensor is replaced.**
- **The O<sub>2</sub> calibration must be performed when the system is in Standby.**
- **If the calibration fails, check for technical alarm and troubleshoot it, if there is any. Then do the calibration again.**
- **In case of repeated calibration failures, replace the O<sub>2</sub> sensor and do the calibration again. If it still fails, contact your service personnel or Mindray..**
- **Obey the relevant stipulations about biohazard when disposing the discarded O<sub>2</sub> sensor. Do not burn it.**

---

The O<sub>2</sub> sensor must be removed from the breathing system before calibrating it at 21%. The O<sub>2</sub> sensor can be reinstalled after verifying that there is no water build-up in the O<sub>2</sub> sensor and the connection port on the breathing system.

## 7.4.1 Calibrate the O<sub>2</sub> Sensor



### 7.4.1.1 21% O<sub>2</sub> Sensor Calibration

#### NOTE

---

- **The breathing system automatically seals off the O<sub>2</sub> sensor port when the O<sub>2</sub> sensor is removed.**
- 

To calibrate at 21% O<sub>2</sub>, do as follows:

1. Ensure that the system is in Standby mode. If not, select  key to enter Standby mode after confirmation.
2. Select  key → [General] tab → [Calibrate O<sub>2</sub> Sensor]. Only 21% O<sub>2</sub> sensor calibration is available in the General tab,  
or  
Select  key → [System] (system password needed) → [Calibration] → [O<sub>2</sub> Sensor]. Both 21% and 100% O<sub>2</sub> sensor calibrations are available in the System tab. The 21% button is highlighted by default.

#### NOTE

---

- **In the System tab, 21% oxygen sensor calibration must be completed before performing 100% calibration. The 100% button is disabled if a 21% oxygen sensor calibration has not been successfully completed within 72 h.**
- 

3. Remove the O<sub>2</sub> sensor from the O<sub>2</sub> sensor port on the breathing system. Allow three (3) minutes for the sensor to acclimate to the environment.
4. Carefully follow the on-screen prompts to prepare for calibration.
5. Select the [Begin] button to start 21% O<sub>2</sub> sensor calibration. The system will indicate the calibration status when the process is completed.

- 
- When 21% O<sub>2</sub> sensor calibration is successfully completed, reinstall the O<sub>2</sub> sensor into the O<sub>2</sub> sensor port on the breathing system. If an error code in red (e.g., 00 00 00 10) is displayed, see the following table for troubleshooting information.



### 7.4.1.2 100% O<sub>2</sub> Sensor Calibration

#### NOTE

---

- **If the calibration fails, check for technical alarm and troubleshoot it, if there is. Then do the calibration again.**
  - **In case of repeated calibration failures, replace the O<sub>2</sub> sensor and do the 21% O<sub>2</sub> calibration again. Calibrate at 100% O<sub>2</sub> again after 21% O<sub>2</sub> calibration is completed. If it still fails, contact your service personnel or Mindray.**
- 

To calibrate at 100% O<sub>2</sub>, do as follows:

- Ensure that 21% O<sub>2</sub> calibration is already completed successfully and that no [O<sub>2</sub> Supply Failure] alarm occurs.
- Ensure that the system is in Standby mode. If not, select  key to enter Standby mode after confirmation.
- Select  key → [System] (system password needed) → [Calibration] → [O<sub>2</sub> Sensor]. Both 21% and 100% O<sub>2</sub> sensor calibrations are available in the System tab. Select [100%] button to perform 100% O<sub>2</sub> sensor calibration.
- Ensure that the animal is disconnected from the system.
- Open the animal breathing circuit to the air..
- Turn on the O<sub>2</sub> supply, adjust the flow above 8 L/min, and fully fill the bellows rapidly. Set Air and N<sub>2</sub>O flows to the minimum.
- After 3 min., select the [Begin] button to start 100% O<sub>2</sub> sensor calibration. The system will indicate the calibration status when the process is completed. If an error code in red (e.g., 00 00 00 10) is displayed, see the following table for troubleshooting information.
- After calibration, select [Done] button to close the [Calibration] window.

---

## 7.4.2 Troubleshooting Information

Error Code	Description	Recommended Action
00 00 00 01	O <sub>2</sub> sensor calibration is cancelled.	Perform O <sub>2</sub> sensor calibration again.
00 00 00 02	O <sub>2</sub> supply pressure is low. During 100% calibration process, O <sub>2</sub> supply pressure was not sufficient.	Check that the O <sub>2</sub> sensor is connected to the cable correctly. Check the O <sub>2</sub> supply pressure. Check that the O <sub>2</sub> sensor output voltage in the calibration menu is steady. Replace the O <sub>2</sub> sensor.
00 00 00 04	O <sub>2</sub> sensor is disconnected. Sampled data is greater than 2900 (AD value).	Check that the O <sub>2</sub> sensor is connected to the cable correctly. Check that the O <sub>2</sub> sensor output voltage in the calibration menu is steady. Replace the O <sub>2</sub> sensor.
00 00 00 08	21% calibration value is outside of the expected range (150~500) (AD value).	Check that the O <sub>2</sub> sensor is connected to the cable correctly. Check that the O <sub>2</sub> sensor is exposed to 21% O <sub>2</sub> . Check that the O <sub>2</sub> sensor output voltage in the calibration menu is steady. Replace the O <sub>2</sub> sensor.
00 00 00 10	100% calibration value is outside of the expected range (800~2028) (AD value).	Check that the O <sub>2</sub> sensor is connected to the cable correctly. Check that the O <sub>2</sub> sensor is exposed to 100% O <sub>2</sub> . Check that the O <sub>2</sub> sensor output voltage in the calibration menu is steady. Replace the O <sub>2</sub> sensor.
00 00 00 20	Error writing to EEPROM.	Repeat the calibration. Replace the O <sub>2</sub> sensor. Replace the CPU board.

---

## 7.5 Water Build-up in the Flow Sensor

### 7.5.1 Prevent Water Build-up

Water comes from the condensation of exhaled gas and a chemical reaction between CO<sub>2</sub> and the soda lime in the CO<sub>2</sub> absorbent canister. At lower fresh gas flows more water builds up because of the following:

- ◆ Less gas in the breathing system is removed through AGSS and gets replaced with fresh gas.
- ◆ More CO<sub>2</sub> stays in the CO<sub>2</sub> absorbent canister to react and produce water.
- ◆ More moist, exhaled gas stays in the breathing system and CO<sub>2</sub> absorbent canister to produce condensed water.

Check the inspiratory and expiratory flow sensors when abnormal flow waveform or unstable tidal volume fluctuation is detected. Check the sensor for water build-up. If there is water build-up, dry it before use.

To prevent water build-up:

- ◆ Use a filter between the flow sensor and the animal to limit water condensation in the flow sensor.
- ◆ Check the water trap for water before using the Anesthesia System. If there is water build-up, dry it immediately.

### 7.5.2 Clear Water Build-up

The water built-up inside the flow sensor will result in inaccurate measured value of tidal volume. If there is water built-up inside the flow sensor, remove the sensor and wipe the water. Then reinstall the sensor for use.

---

#### **WARNING**

---

- **Check water build-up inside the flow sensor every time before system use. Build-up water in the flow sensor causes erroneous readings.**
  - **Ensure that all breathing system parts are completely dried after the breathing system is cleaned and disinfected.**
-

---

## 7.6 AGSS Transfer Tube Maintenance

Check the tube of the AGSS transfer system. Replace it if it is damaged.



## 7.7 Electrical Safety Inspection

### NOTE

- 
- Perform electrical safety inspection after servicing or routine maintenance. Before the electrical safety inspection, ensure all the covers, panels, and screws are correctly installed.
  - The electrical safety inspection should be performed once a year.
- 

### 7.7.1 Auxiliary Electrical Outlet Test

Verify the mains voltage is present at each auxiliary outlet when the anesthesia machine is connected with power.

### 7.7.2 Electrical Safety Inspection Test

1. Perform protective earth resistance test:
  - a. Plug the probes of the analyzer into the protective earth terminal and equipotential terminal of the AC power cord.
  - b. Test the earth resistance with a current of 25 A.
  - c. Verify the resistance is less than 0.1 ohms (100 mohm).
  - d. Plug the probes of the analyzer into the protective earth terminal of the AC power cord and the protective earth terminal of any auxiliary outlet. Repeat steps b and c.
  - e. If the resistance is larger than 0.1 ohms (100 mohm) but less than 0.2 ohms (200 mohm), disconnect the AC power cord and plug the probe that is previously plugged in the protective earth terminal of the AC power cord into the protective earth contact of the power outlet. Repeat steps a to d.



---

2. Perform the following earth leakage current tests:

- ◆ normal polarity;
- ◆ reverse polarity;
- ◆ normal polarity with open neutral; and
- ◆ reverse polarity with open neutral.

3. Verify the maximum leakage current does not exceed 500  $\mu$ A (0.5 mA) in the first two tests. For the last two tests, verify that the maximum leakage current does not exceed 1000  $\mu$ A (1 mA).

4. Verify the maximum leakage current does not exceed 100  $\mu$  A (0.1 mA) in the first two tests.

For the next four tests, verify that the maximum leakage current does not exceed 500  $\mu$  A (0.5 mA). And for the last two tests, verify that the maximum leakage current does not exceed 5000  $\mu$  A (5 mA).

5. Verify the maximum leakage current does not exceed 100  $\mu$  A (0.1 mA) in the first two tests.

For the last two tests, verify that the maximum leakage current does not exceed 500  $\mu$  A (0.5 mA)

---

## **WARNING**

- **Always have the leakage current checked after a saline or blood spill, or immediately after a major surge in the house electrical system and after every time the WATO covers have been opened.**
- **Keep in mind that liquids such as saline and Ringer's as well as blood are all excellent conductors of electricity. Avoid touching any part of the system with wet hands. Always operate anesthesia machine anesthesia machine with clean, dry hands.**

---

## **NOTE**

- **Ensure the safety analyzer is authorized by certificate organizations (UL, CSA, or AAMI etc.). Follow the instructions of the analyzer manufacturer.**
-

---

**FOR YOUR NOTES**

# 8 CO<sub>2</sub> Monitoring

---

---

## 8.1 Introduction

CO<sub>2</sub> monitoring is a continuous, non-invasive technique for determining the concentration of CO<sub>2</sub> in the animal's airway by measuring the absorption of infrared (IR) light of specific wavelengths. The CO<sub>2</sub> has its own absorption characteristic and the amount of light passing the gas probe depends on the concentration of the measured CO<sub>2</sub>. When a specific band of IR light is passed through respiratory gas samples, some of IR light will be absorbed by the CO<sub>2</sub> molecules. The amount of IR light transmitted after it has been passed through the respiratory gas sample is measured with a photodetector. From the amount of IR light measured, the concentration of CO<sub>2</sub> is calculated.

There are two methods for measuring CO<sub>2</sub> in the animal's airway:

1. Mainstream measurement  
Use a CO<sub>2</sub> sensor attached to an airway adapter directly inserted into the animal's breathing system.
2. Sidestream/microstream measurement  
Sample expired animal gas at a constant sample flow from the animal's airway, and analyze it with a CO<sub>2</sub> sensor built into the CO<sub>2</sub> module.

The measurement provides:

1. CO<sub>2</sub> waveform.
2. End-tidal CO<sub>2</sub> (EtCO<sub>2</sub>) value: the CO<sub>2</sub> value measured at the end of the expiration phase.
3. Fraction of inspired CO<sub>2</sub> (FiCO<sub>2</sub>): the CO<sub>2</sub> value measured during inspiration phase.

The rated respiration rate range of sidestream EtCO<sub>2</sub> module is 0 to 120 bpm, and the data sample rate is 50 Hz. And the EtCO<sub>2</sub> concentration reading is using the highest values respectively of the temporal CO<sub>2</sub> waveform.

The rated respiration rate range of mainstream EtCO<sub>2</sub> module is 0 to 150 bpm, and the data sample rate is 100 Hz. And the EtCO<sub>2</sub> concentration reading is using the peak of the expired CO<sub>2</sub> waveform (Averaging selection: 1 breath, 10 s, 20 s).

---

The method used to determine the rated respiration rate range: Utilize a valve to permit switching between the two sampling gases at different frequencies (simulating the range of specified breath rates). Record the EtCO<sub>2</sub> value presented for each frequency. By drawing the coordinate diagram which indicates the corresponding relationship between end-tidal value and breathing frequency, the range of breathing frequency can be obtained, with EtCO<sub>2</sub> measurement accuracy complying with the specification.

## NOTE

- 
- If the system is configured with either mainstream CO<sub>2</sub>, sidestream CO<sub>2</sub> or microstream CO<sub>2</sub>, this function will have the automatic atmospheric pressure compensation function.
- 

## 8.2 Identify CO<sub>2</sub> Module

Sidestream CO<sub>2</sub> module, microstream CO<sub>2</sub> module and mainstream CO<sub>2</sub> module are shown below.

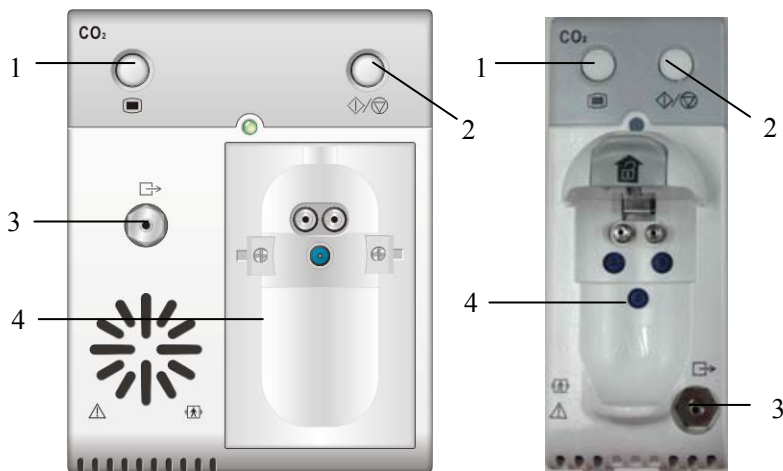

Sidestream CO<sub>2</sub> module

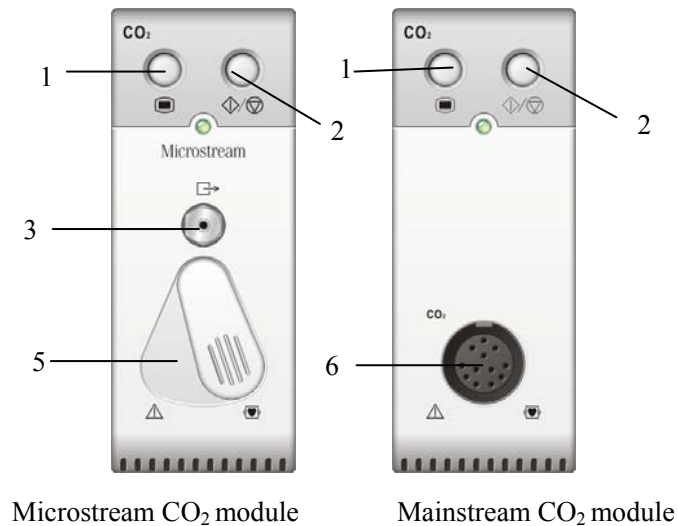

1. CO<sub>2</sub> setup key
2. Measure/standby key
3. Gas outlet
4. CO<sub>2</sub> watertrap socket
5. Sampling tube connector
6. CO<sub>2</sub> sensor connector

If you measure CO<sub>2</sub> using AG module, refer to **9 AG and O<sub>2</sub> Concentration Monitoring**

## 8.3 Use a Sidestream CO<sub>2</sub> Module

### NOTE

- This section is only applicable to the anesthesia machine configured with sidestream CO<sub>2</sub> module.

---

### 8.3.1 Prepare to Measure CO<sub>2</sub>

1. Attach the watertrap to the watertrap socket and then connect the CO<sub>2</sub> components as shown below.

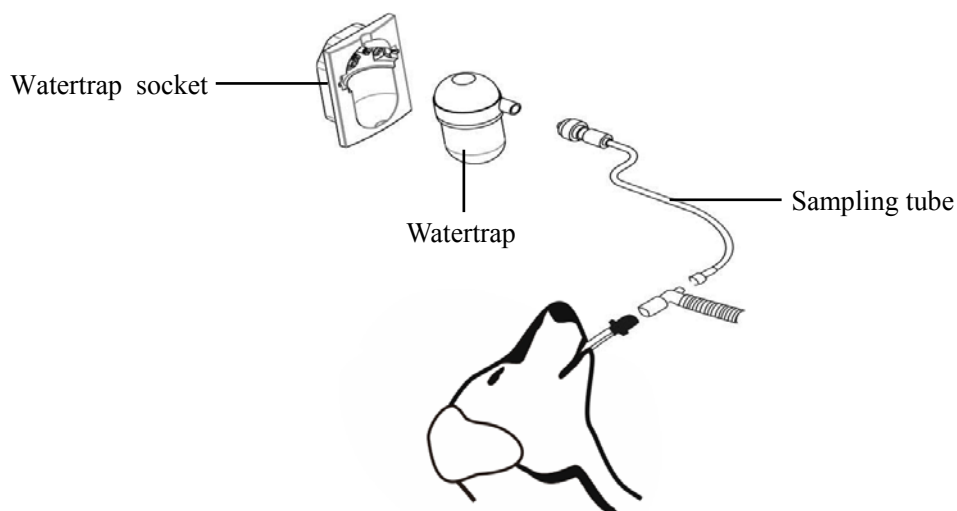

2. By default, the CO<sub>2</sub> module is in measure mode. The [CO<sub>2</sub> Loaded Successfully] message appears on the screen when the CO<sub>2</sub> module is plugged in. And then [CO<sub>2</sub> Startup] message appears.
3. After start-up is finished, the message [CO<sub>2</sub> Warmup] is displayed. The CO<sub>2</sub> module is in ISO accuracy mode. If you perform CO<sub>2</sub> measurements during warm-up, the measurement accuracy may be compromised.
4. After warm-up is finished, the CO<sub>2</sub> module enters full accuracy mode.

#### NOTE

- 
- To extend the lifetime of the watertrap and CO<sub>2</sub> module, disconnect the watertrap and set the working mode of the module to standby when CO<sub>2</sub> monitoring is not required.
- 

#### CAUTION

- 
- The watertrap collects water drops condensed in the sampling line and therefore prevents them from entering the module. If the collected water reaches a certain amount, you should drain it to avoid airway blockage.
  - The watertrap has a filter preventing bacterium, vapor and animal secretions from entering the module. After a long-term use, dust or other substances may compromise the performance of the filter or even block the airway. In this case, replace the watertrap. Replacing the watertrap once a month is recommended. Or,
-

---

---

 **CAUTION**

replace the watertrap when it is found leaky, damaged or contaminated.



---

### 8.3.2 Make CO<sub>2</sub> Settings

By selecting the  key → [General] tab → [CO<sub>2</sub> Setup] menu, you can make CO<sub>2</sub> settings described below.

#### 8.3.2.1 Set Operating Mode

The default operating mode of the CO<sub>2</sub> module is [Measure] when the anesthesia machine is turned on for the first time. If the system enters the Standby mode, the CO<sub>2</sub> module will also enter the Standby mode. If the system exits the Standby mode, the CO<sub>2</sub> module will also exit the Standby mode and enter the measure mode.

If the current CO<sub>2</sub> module is in Standby mode, you must push the  key, or select the  key → [General] tab → [CO<sub>2</sub> Setup] menu → [Operating Mode] → [Measure] to start the CO<sub>2</sub> module.

During standby, the working components of the CO<sub>2</sub> module such as gas pump and infrared source are automatically turned off to extend the service life of the module.

#### 8.3.2.2 Set Flow Rate

1. Select the  key → [General] tab → [CO<sub>2</sub> Setup] menu.
2. Select the [Flow Rate] button.
3. Choose between [High] and [Low], as follows:
  - ◆ High: 150 mL/min for adult or pediatric animal; 120 mL/min for infant animal
  - ◆ Low: 120 mL/min for adult or pediatric animal; 100 mL/min for infant animal
4. Select the [Accept] button to confirm the change.

---

---

 **WARNING**

- Please consider the animal's actual breathing capability and select the appropriate pump rate when setting the pump rate.
-

---

### 8.3.2.3 Set Gas Compensations

---

#### **WARNING**

---

- **Ensure that the appropriate compensations are used. Inappropriate compensations may cause inaccurate measured values and result in misdiagnosis.**
- 

1. Select the  key → [General] tab → [CO<sub>2</sub> Setup] menu.
2. Set the following compensations based on the actual conditions:
  - ◆ [O<sub>2</sub> Comp.]
  - ◆ [N<sub>2</sub>O Comp.]

The total of the concentrations of the above three gas compensations cannot be greater than 100%.

### 8.3.2.4 Set Humidity Compensation

The CO<sub>2</sub> module is configured to compensate CO<sub>2</sub> readings for either Body Temperature and Pressure, Saturated gas (BTPS), to account for humidity in the animal's breath, or Ambient Temperature and Pressure, Dry gas (ATPD).

1. ATPD:  $P_{CO_2}(\text{mmHg}) = CO_2(\text{vol}\%) \times P_{amb} / 100$
2. BTPS:  $P_{CO_2}(\text{mmHg}) = CO_2(\text{vol}\%) \times (P_{amb} - 47) / 100$

Where,  $P_{CO_2}$  = partial pressure,  $\text{vol}\%$  = CO<sub>2</sub> concentration,  $P_{amb}$  = ambient pressure, and unit is mmHg.

For CO<sub>2</sub> module, humidity compensation is switched on or off based on the actual situations. To set the humidity compensation:

1. Select  key → [General] tab → [CO<sub>2</sub> Setup] menu.
2. Select the [Humidity Comp.] button.
3. Select either [On] or [Off]; for BTPS or ATPD; depending on which compensation applies.
4. Select the [Accept] button to confirm the change.



---

### 8.3.2.5 Load CO<sub>2</sub> Defaults

1. Select  key → [General] tab → [CO<sub>2</sub> Setup] menu.
2. Select the [Load CO<sub>2</sub> Defaults] button.
3. Select the [Yes] button to confirm the change.

### 8.3.2.6 Set CO<sub>2</sub> Scale

1. Select  key → [General] tab.
2. Select the [CO<sub>2</sub> Scale] button.
3. Choose the scale you need.
4. Select the [Accept] button to confirm the change.

### 8.3.2.7 Set CO<sub>2</sub> Placement

1. Select  key → [Display] tab.
2. Select the [CO<sub>2</sub> Placement] button.
3. Choose [Top] or [Bottom].
4. Select the [Accept] button to confirm the change.

### 8.3.2.8 Set CO<sub>2</sub> Unit

1. Select  key → [System] tab.
2. Select the [Unit] button → [CO<sub>2</sub>] button.
3. Choose [mmHg] or [kPa] or [%].
4. Select the [Accept] button to confirm the change.

## 8.3.3 Measurement Limitations

Measurement accuracy may degrade due to:

- Leakage or internal leakage of the sample gas.
- Mechanical shock
- Cyclic pressure which is greater than 10 kPa (100 cmH<sub>2</sub>O)
- Other interference source (if present)
- Humidity or condensates

---

Measurement accuracy may be affected by the breath rate and I/E ratio as follows:

EtCO<sub>2</sub> is within specification for breath rate  $\leq$  60 bpm and I/E ratio  $\leq$  1:1;

EtCO<sub>2</sub> is within specification for breath rate  $\leq$  30 bpm and I/E ratio  $\leq$  2:1.

Measurement accuracy is unspecified for breath rate larger than 60 bpm.

### 8.3.4 Troubleshooting

When the sampling system of the CO<sub>2</sub> module works incorrectly, check if the sampling tube is kinked. If not, remove the sampling tube from the watertrap. Then, if a prompt message indicating airway malfunction appears on the screen, it means that the watertrap is occluded. In this case, you must replace the watertrap. If no such prompt message is displayed, it means that the sampling tube is occluded. Then you must replace the sampling tube.

### 8.3.5 Scavenge the Sample Gas

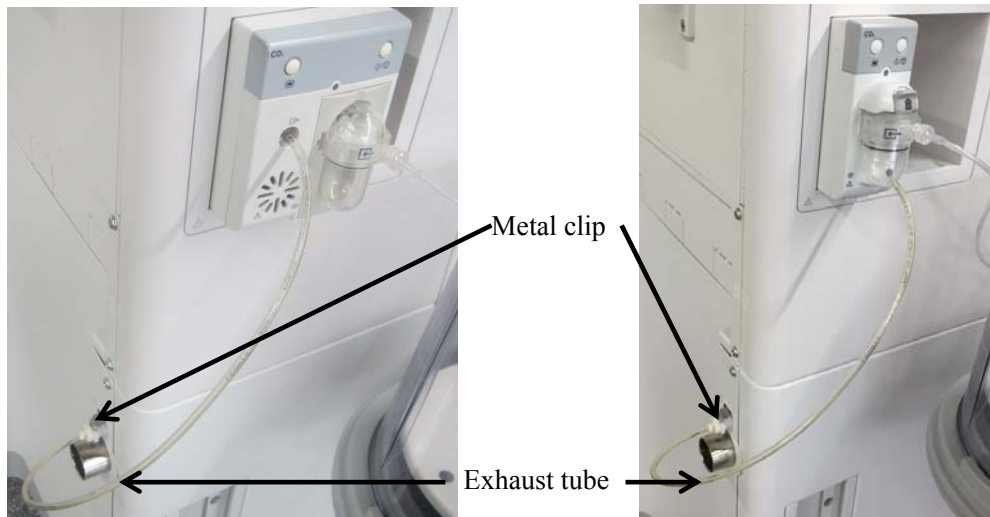

To scavenge the sample gas to the waste gas disposal system, depress the metal clip and then insert the connector of the exhaust tube into the sample gas return port marked . A click indicates that the connector of the exhaust tube is installed in place, as shown above. Depress the metal clip to release exhaust tube connector. Then pull out the connector.

---

### **WARNING**

- **When using CO<sub>2</sub> module to perform CO<sub>2</sub> measurements on the animal who is receiving or has recently received anesthetic agents, connect the gas outlet to the waste gas disposal system to prevent the medical staff from breathing in the anesthetic agent.**
-

---

### 8.3.6 Zero the Sensor

Zeroing the sensor aims to eliminate the effect of baseline drift on the readings during the measurement so as to ensure measurement accuracy.

For sidestream CO<sub>2</sub> module, a zero calibration is carried out automatically when necessary. You can also start a manual zero calibration when deemed necessary. You do not need to disconnect the sensor from the breathing system when performing the zeroing.

1. Ensure that the system is in Standby mode.
2. Select  key → [System] tab (system password needed).
3. Select the [Calibration] button → [CO<sub>2</sub> Module] button.
4. Select the [Zero] button to start zeroing the CO<sub>2</sub> module. The system will display the results of the zero status when the process is completed.
  - ◆ If zeroing fails, you can select [Retry] button to zero again or select [Done] button to enter the calibration screen.
  - ◆ If zeroing is completed successfully, you can select [Continue] button to enter the calibration screen.
5. If there is no need to zero, you can select [Accept] button to close the setup window.

### 8.3.7 Calibrate the Sensor

For sidestream CO<sub>2</sub> module, a calibration should be performed once a year or when the measured value has a great deviation.

#### NOTE

---

- Advice on the proper disposal of calibration gases refer to chapter 8.3.5 Scavenge the Sample Gas.
- 

## 8.4 Use a Microstream CO<sub>2</sub> Module

#### NOTE

---

- This section is only applicable to the anesthesia machine configured with microstream CO<sub>2</sub> module.
-

---

## 8.4.1 Prepare to Measure CO<sub>2</sub>

1. Plug the sampling tube into the sampling tube connector and then connect the CO<sub>2</sub> components as shown below.

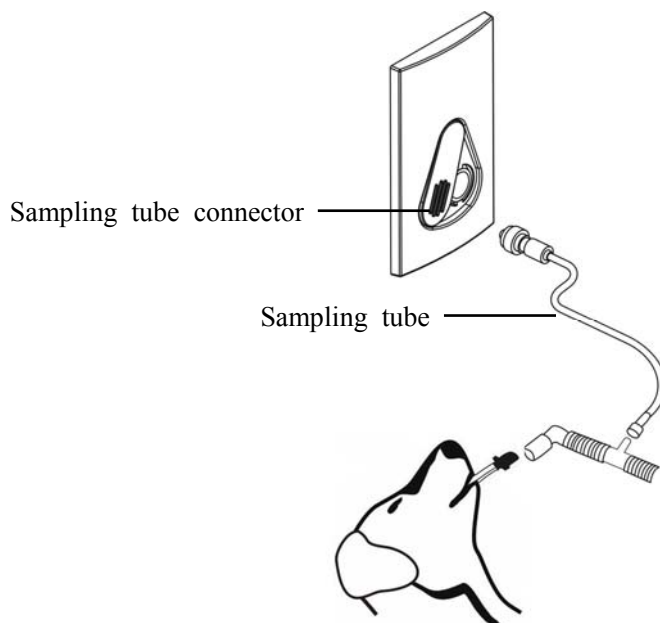

2. By default, the microstream CO<sub>2</sub> module is in measure mode. The [**CO<sub>2</sub> Loaded Successfully**] message appears on the screen when the CO<sub>2</sub> module is plugged in. And then [**CO<sub>2</sub> Startup**] message appears.
3. After warm-up is finished, you can perform CO<sub>2</sub> measurements.

## 8.4.2 Make CO<sub>2</sub> Settings

By selecting the  key and then [**General**] tab → [**CO<sub>2</sub> Setup**] menu, you can make CO<sub>2</sub> settings described below.

### 8.4.2.1 Set Operating Mode

The default operating mode of the CO<sub>2</sub> module is [**Measure**] when the anesthesia machine is turned on for the first time. If the system enters the Standby mode, the CO<sub>2</sub> module will also enter the Standby mode. If the system exits the Standby mode, the CO<sub>2</sub> module will also exit the Standby mode and enter the measure mode.

If the current CO<sub>2</sub> module is in Standby mode, you must push the  key or select the

 key → [**General**] tab → [**CO<sub>2</sub> setup**] menu → [**Operating Mode**] → [**Measure**]

to start the CO<sub>2</sub> module.

During the Standby, the working components of the CO<sub>2</sub> module such as gas pump and infrared source are automatically turned off to extend the service life of the module.

---

### 8.4.2.2 Set Maximum Hold

In the CO<sub>2</sub> parameter area, EtCO<sub>2</sub> and FiCO<sub>2</sub> values are refreshed in real-time. To set EtCO<sub>2</sub> and FiCO<sub>2</sub>:

1. Access  key → [General] tab → [CO<sub>2</sub> Setup] menu.
2. Select [Max Hold] and select:
  - ◆ [Single Breath]: EtCO<sub>2</sub> and FiCO<sub>2</sub> are calculated based on each breath.
  - ◆ [10 s], [20 s] or [30 s]: EtCO<sub>2</sub> and FiCO<sub>2</sub> refer to the highest and the lowest CO<sub>2</sub> values measured respectively within the configured time period (10 s or 20 s).

### 8.4.2.3 Set Humidity Compensation

The CO<sub>2</sub> module is configured to compensate CO<sub>2</sub> readings for either Body Temperature and Pressure, Saturated Gas (BTPS), to account for humidity in the animal's breath, or Ambient Temperature and Pressure, Dry Gas (ATPD).

1. ATPD:  $P_{CO_2}(mmHg) = CO_2(vol\%) \times P_{amb} / 100$
2. BTPS:  $P_{CO_2}(mmHg) = CO_2(vol\%) \times (P_{amb} - 47) / 100$

Where,  $P_{CO_2}$  = partial pressure,  $vol\%$  = CO<sub>2</sub> concentration,  $P_{amb}$  = ambient pressure, and unit is mmHg.

For CO<sub>2</sub> module, humidity compensation is switched on or off based on the actual situations. To set the humidity compensation:

1. Select  key → [General] tab → [CO<sub>2</sub> Setup] menu.
2. Select the [Humidity Compens.] button.
3. Select either [On] for BTPS or [Off] for ATPD, depending on which compensation applies.
4. Select the [Accept] button to confirm the change.

### 8.4.2.4 Load CO<sub>2</sub> Defaults

1. Select  key → [General] tab → [CO<sub>2</sub> Setup] menu.
2. Select the [Load CO<sub>2</sub> Defaults] button.
3. Select the [Yes] button to confirm the change.

---

#### 8.4.2.5 Set CO<sub>2</sub> Scale

1. Select  key → [General] tab.
2. Select the [Set CO<sub>2</sub> Scale] button.
3. Choose the scale you need.
4. Select the [Accept] button to confirm the change.

#### 8.4.2.6 Set CO<sub>2</sub> Placement

1. Select  key → [Display] tab.
2. Select the [CO<sub>2</sub> Placement] button.
3. Choose [Top] or [Bottom].
4. Select the [Accept] button to confirm the change.

#### 8.4.2.7 Set CO<sub>2</sub> Unit

1. Select  key → [System] tab.
2. Select the [Unit] button → [CO<sub>2</sub>] button.
3. Choose [mmHg] or [kPa] or [%].
4. Select the [Accept] button to confirm the change.

### 8.4.3 Measurement Limitations

Measurement accuracy may degrade due to:

- Leakage or internal leakage of the sample gas.
- Mechanical shock
- Cyclic pressure which is greater than 10 kPa (100 cmH<sub>2</sub>O)
- Other interference source (if present)
- Humidity or condensates

Measurement accuracy may be affected by the breath rate and I/E ratio as follows:

EtCO<sub>2</sub> is within specification for breath rate  $\leq$  40 bpm and I/E ratio  $\leq$  1:1;

EtCO<sub>2</sub> is within specification for breath rate  $\leq$  20 bpm and I/E ratio  $\leq$  2:1.

Measurement accuracy is unspecified for breath rate larger than 40 bpm.

---

#### 8.4.4 Scavenge the Sample Gas

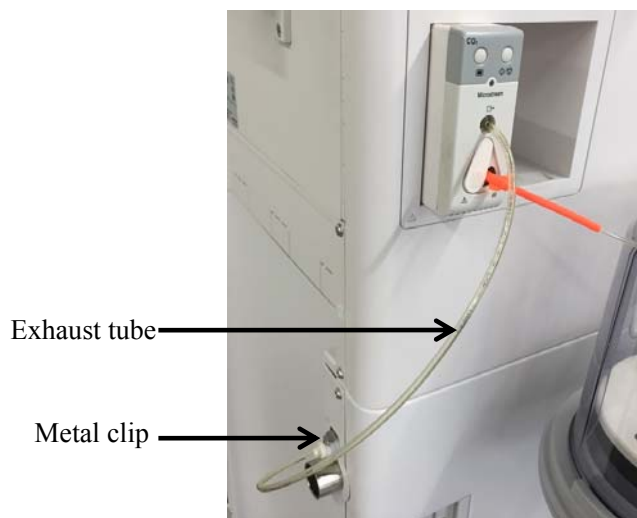

To scavenge the sample gas to the waste gas disposal system, depress the metal clip and then insert the connector of the exhaust tube into the sample gas return port marked . A click indicates that the connector of the exhaust tube is installed in place, as shown above.

Depress the metal clip to release exhaust tube connector. Then pull out the connector.

---

#### **WARNING**

- **When using microstream CO<sub>2</sub> module to perform CO<sub>2</sub> measurements on the animal who is receiving or has recently received anesthetic agents, connect the gas outlet to the waste gas disposal system to prevent the medical staff from breathing in the anesthetic agent.**
- 

#### 8.4.5 Zero the Sensor

Zeroing the sensor aims to eliminate the effect of baseline drift on the readings during the measurement so as to ensure measurement accuracy.

For microstream CO<sub>2</sub> module, a zero calibration is carried out automatically when necessary. You can also start a manual zero calibration when deemed necessary. You do not need to disconnect the sensor from the breathing system when performing the zeroing.

- 
1. Ensure that the system is in Standby mode.
  2. Select  key → [System] tab (system password needed).
  3. Select the [Calibration] button → [CO<sub>2</sub> Module] button.
  4. Select the [Zero] button to start zeroing the CO<sub>2</sub> module.
    - ◆ If zeroing fails, you can select [Retry] button to zero again or select [Done] button to enter the calibration screen.
    - ◆ If zeroing is completed successfully, you can select [Continue] button to enter the calibration screen.
  5. If there is no need to zero, you can select [Accept] button to close the setup window.

## 8.4.6 Calibrate the Sensor

For microstream CO<sub>2</sub> module, a calibration should be performed once a year or when the measured value has a great deviation.

### NOTE

- 
- Advice on the proper disposal of calibration gases refer to chapter 8.4.4 Scavenge the Sample Gas.
- 

## 8.4.7 Oridion Information

# Microstream

This trademark is registered in Israel, Japan, German and America already.

### Oridion Patents

This device and the CO<sub>2</sub> sampling consumables designed for use herewith are covered by one or more of the following USA patents: 4,755,675; 5,300,859; 5,657,750; 5,857,461 and international equivalents. USA and international patents are pending.

### No Implied License

Possession or purchase of this device does not convey any express or implied license to use the device with unauthorized CO<sub>2</sub> sampling consumables, which would, alone, or in combination with this device, fall within the scope of one or more of the patents relating to this device and/or CO<sub>2</sub> sampling consumable.



---

## 8.5 Use a Mainstream CO<sub>2</sub> Module

### NOTE

- 
- This section is only applicable to the anesthesia machine configured with mainstream CO<sub>2</sub> module.
- 

### 8.5.1 Prepare to Measure CO<sub>2</sub>

1. Connect the sensor to the CO<sub>2</sub> module.
2. By default, the mainstream CO<sub>2</sub> module is in measure mode. The [CO<sub>2</sub> Loaded Successfully] message appears on the screen when the CO<sub>2</sub> module is plugged in. And then [CO<sub>2</sub> Startup] message appears.
3. After warm-up is finished, connect the sensor to the airway adapter.
4. Perform a zero calibration, referring to *8.4.5 Zero the Sensor*.
5. After the zero calibration is finished, connect the airway as shown below.

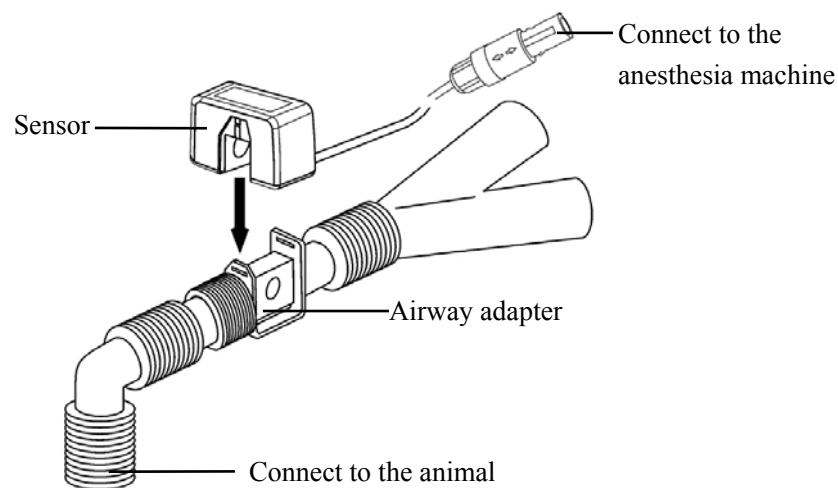

6. Ensure that there are no leakages in the airway and then perform CO<sub>2</sub> measurements.

### NOTE



- 
- Always position the sensor with the adapter in an upright position to avoid collection of fluids on the windows of the adapter. Large concentrations of fluids at this point will obstruct gas analysis.
-

---

## 8.5.2 Make CO<sub>2</sub> Settings

By selecting the  key and then [General] tab → [CO<sub>2</sub> Setup] menu, you can make CO<sub>2</sub> settings described below.

### 8.5.2.1 Set Operating Mode

The default operating mode of the CO<sub>2</sub> module is [Measure] when the anesthesia machine is turned on for the first time. If the current CO<sub>2</sub> module is in Standby mode, you must push the  key or select the  key → [General] tab → [CO<sub>2</sub> Setup] menu → [Operating Mode] → [Measure] to start the CO<sub>2</sub> module. When the anesthesia machine restarts, the CO<sub>2</sub> module automatically continues with the previously selected operating mode.

During the standby, the working components of the CO<sub>2</sub> module such as gas pump and infrared source are automatically turned off to extend the service life of the module.

### 8.5.2.2 Set Maximum Hold

In the CO<sub>2</sub> parameter area, EtCO<sub>2</sub> and FiCO<sub>2</sub> values are refreshed in real-time. To set EtCO<sub>2</sub> and FiCO<sub>2</sub>:

1. Access  key → [General] tab → [CO<sub>2</sub> Setup] menu.
2. Select [Max Hold] and select:
  - ◆ [Single Breath]: EtCO<sub>2</sub> and FiCO<sub>2</sub> are calculated based on each breath.
  - ◆ [10 s] and [20 s]: EtCO<sub>2</sub> and FiCO<sub>2</sub> refer to the highest and the lowest CO<sub>2</sub> values measured respectively within the configured time period (10 s or 20 s).

### 8.5.2.3 Set Barometric Pressure

1. Access  key → [General] tab → [CO<sub>2</sub> Setup] menu.
2. Set [Barometric Pressure] based on the actual conditions.

---

### 8.5.2.4 Set Gas Compensations

---

#### **WARNING**

---

- **Ensure that the appropriate compensations are used. Inappropriate compensations may cause inaccurate measured values and result in misdiagnosis.**
- 

1. Access  key → [General] tab → [CO<sub>2</sub> Setup] menu.
2. Set the following compensations based on the actual conditions:
  - [Balance Gas]
    - ◆ [Air]: when air is used as a balance gas.
    - ◆ [N<sub>2</sub>O]: when N<sub>2</sub>O is used as a balance gas.
  - [O<sub>2</sub> Compen.]
    - ◆ [OFF]: when the amount of O<sub>2</sub> in the ventilation gas mixture is less than 30%
    - ◆ Other options: selects an appropriate value according to the amount of O<sub>2</sub> in the ventilation gas mixture.
  - [AG Compen.]: enters the concentration of anesthetic gas (if there is) in the ventilation gas mixture to compensate for the effect of anesthetic gas upon the readings.

The total of the concentrations of O<sub>2</sub> compensation and AG compensation cannot be greater than 100%.

### 8.5.2.5 Load CO<sub>2</sub> Defaults

1. Select  key → [General] tab → [CO<sub>2</sub> Setup] menu.
2. Select the [Load CO<sub>2</sub> Defaults] button.
3. Select the [Yes] button to confirm the change.

### 8.5.2.6 Set CO<sub>2</sub> Scale

1. Select  key → [General] tab.
2. Select the [Set CO<sub>2</sub> Scale] button.
3. Choose the scale you need.
4. Select the [Accept] button to confirm the change.

---

### 8.5.2.7 Set CO<sub>2</sub> Placement

1. Select  key → [Display] tab.
2. Select the [CO<sub>2</sub> Placement] button.
3. Choose [Top] or [Bottom].
4. Select the [Accept] button to confirm the change.

### 8.5.2.8 Set CO<sub>2</sub> Unit

1. Select  key → [System] tab.
2. Select the [Unit] button → [CO<sub>2</sub>] button.
3. Choose [mmHg] or [kPa] or [%].
4. Select the [Accept] button to confirm the change.

## 8.5.3 Measurement Limitations

Measurement accuracy may degrade due to:

- Leakage or internal leakage of the sample gas.
- Mechanical shock
- Cyclic pressure which is greater than 10 kPa (100 cmH<sub>2</sub>O)
- Other interference source (if present)
- Humidity or condensates

Measurement accuracy may be affected by the breath rate and I/E ratio as follows:

EtCO<sub>2</sub> is within specification for breath rate  $\leq$  60 bpm and I/E ratio  $\leq$  1:1;

EtCO<sub>2</sub> is within specification for breath rate  $\leq$  30 bpm and I/E ratio  $\leq$  2:1.

Measurement accuracy is unspecified for breath rate larger than 60 bpm.

---

## 8.5.4 Zero the Sensor

Zeroing the sensor aims to eliminate the effect of baseline drift on the readings during the measurement so as to ensure measurement accuracy.

For mainstream CO<sub>2</sub> module, zero the sensor when:

1. The adapter is replaced.
2. The sensor is re-connected to the module.
3. The message **[CO<sub>2</sub> Zero Required]** is displayed. In this case, check the airway adapter for blockage. If a blockage is detected, clear or replace the adapter.

To zero the sensor, do as follows:

1. Connect the sensor to the CO<sub>2</sub> module.
2. Access the  key → **[General]** tab → **[CO<sub>2</sub> Setup]** menu, and set **[Operating Mode]** to **[Measure]**. The message **[CO<sub>2</sub> Warmup]** is displayed.
3. After warm-up is finished, connect the sensor to a clean, dry airway adapter. The adapter should be vented to the air and isolated from CO<sub>2</sub> sources, including ventilator, the animal's breathing and your own breathing.
4. Select **[Zero]** button from the **[CO<sub>2</sub> Setup]** menu and the screen displays **[CO<sub>2</sub> Zero Running]**.
5. A typical zeroing takes about 15 to 20 s. This message disappears after zeroing is completed.

---

### **WARNING**

- **When zeroing the sensor during the measurement, disconnect the sensor from the breathing system first.**
- 

## 8.5.5 Calibrate the Sensor

For the mainstream CO<sub>2</sub> module, calibration is not required. Contact us if calibration is necessary.

---

**FOR YOUR NOTES**

# 9 AG and O<sub>2</sub> Concentration Monitoring

---

## 9.1 Introduction

The anesthetic gas (AG) module measures the animal's anesthetic and respiratory gases, and incorporates the features of the O<sub>2</sub> module as well.

AG is suitable for CONTINUOUS OPERATION.

The AG (anesthesia gas) module determines the concentrations of certain gases using the infrared (IR) light absorption measurement. The gases that can be measured by the AG module absorb IR light. Each gas has its own absorption characteristic. The gas is transported into a sample cell, and an optical IR filter selects a specific band of IR light to pass through the gas. For multiple gas measurement, there are multiple IR filters. Higher concentration of IR absorbing gas causes a lower transmission of IR light. The amount of IR light transmitted after it has been passed through an IR absorbing gas is measured. From the amount of IR light measured, the concentration of gas present can be calculated.

Oxygen does not absorb IR light as other breathing gases and is therefore measured relying on its paramagnetic properties. Inside the O<sub>2</sub> sensor are two nitrogen-filled glass spheres mounted on a strong rare metal taut-band suspension. This assembly is suspended in a symmetrical non-uniform magnetic field. In the presence of paramagnetic oxygen, the glass spheres are pushed further away from the strongest part of the magnetic field. The strength of the torque acting on the suspension is proportional to the oxygen concentration. From the strength of the torque, the concentration of oxygen is calculated.

The measurement provides:

1. CO<sub>2</sub>, AA or N<sub>2</sub>O waveform;
2. Measured parameters: EtCO<sub>2</sub>, FiCO<sub>2</sub>, EtN<sub>2</sub>O, FiN<sub>2</sub>O, EtAA, FiAA and MAC, Where, AA stands for any of the five anesthetic agents: Iso (Isoflurane), Enf (Enflurane), Sev (Sevoflurane), or Hal (Halothane).

The rated respiration rate range of AG module is 2 to 100 bpm, and the data sample rate is 25 Hz. And the EtCO<sub>2</sub> concentration reading is using the highest values respectively of the temporal CO<sub>2</sub> waveform. The FiO<sub>2</sub> concentration reading is using the highest values respectively of the temporal O<sub>2</sub> waveform. The EtN<sub>2</sub>O and EtAA concentration readings are using the temporal value respectively of the waveforms at the moment when the EtCO<sub>2</sub> concentration is being recorded.

The rated respiration rate range of AG module is calculated based on the temporal CO<sub>2</sub> waveform. The method used to determine the rated respiration rate range: Utilize a valve to permit switching between the two sampling gases at different frequencies (simulating the range of specified breath rates). Record the EtCO<sub>2</sub> value presented for each frequency. By drawing the coordinate diagram which indicates the corresponding relationship between end-tidal value and breathing frequency, the range of breathing frequency can be obtained, with EtCO<sub>2</sub> measurement accuracy complying with the specification.

---

## 9.2 Identify AG Modules

The AG module can identify anesthesia gas automatically.

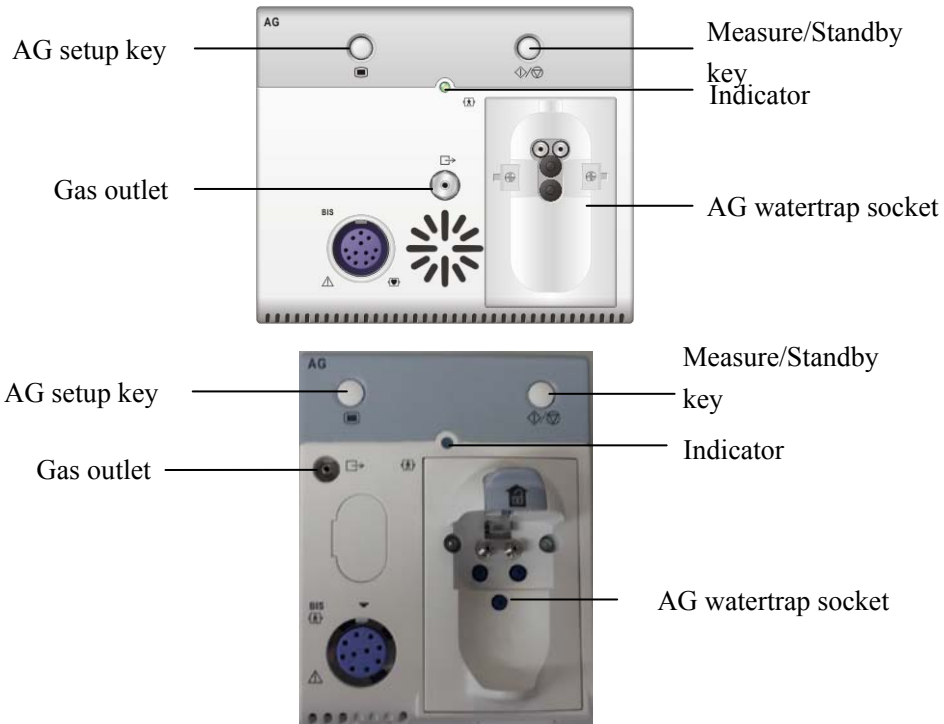

### NOTE

- 
- The AG module is configured with the function of compensating barometric pressure automatically.
- 

## 9.3 Prepare to Measure AG

1. Select the appropriate watertrap according to animal type and attach it to the watertrap socket.
2. Connect one end of the gas sampling tube to the watertrap.
3. Connect the other end of the gas sampling tube to the animal tubing via the airway adapter.



- 
4. Connect the exhaust tube to the gas outlet on the module to scavenge the sample gas into the waste gas disposal system.

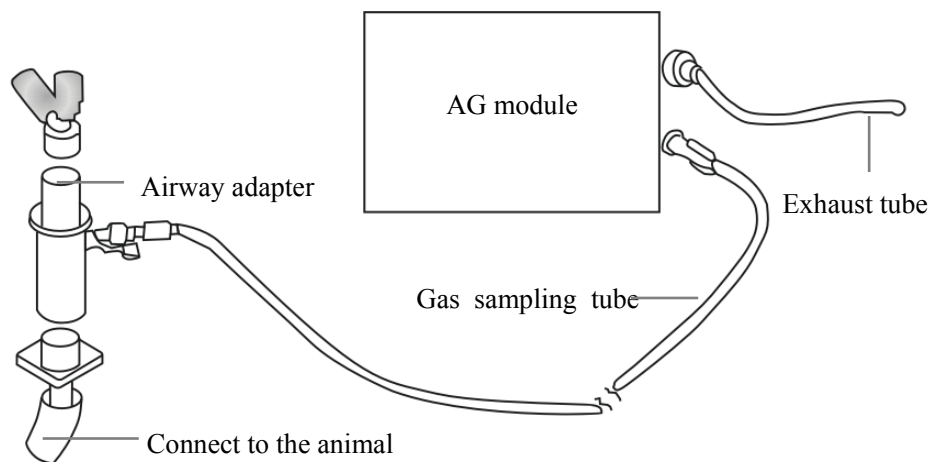

5. By default, the AG module is in measure mode. The message [AG Startup] appears on the screen when the AG module is plugged in.
6. After start-up is finished, the message [AG Warmup] is displayed. The AG module is in ISO accuracy mode. If you perform AG measurements during warm-up, the measurement accuracy may be compromised.
7. After warm-up is finished, the AG module enters full accuracy mode.

---

### CAUTION

- Position the airway adapter properly so that the part connecting to the gas sampling tube is pointing upwards. This prevents condensed water from entering the gas sampling tube and causing an occlusion as a result.
- The watertrap collects water drops condensed in the sampling tube and therefore prevents them from entering the module. If the collected water reaches a certain amount, you should drain it to avoid airway blockage.
- The watertrap has a filter preventing bacterium, vapor and animal secretions from entering the module. After a long-term use, dust or other substances may compromise the performance of the filter or even block the airway. In this case, replace the watertrap. Replacing the watertrap once a month is recommended.

---

### WARNING

- Do not apply adult watertraps to neonatal animals. Otherwise, animal injury could result.
- Ensure that all connections are reliable. Any leak in the system can result in erroneous readings due to animal breathing gas mixed with ambient air.
- There may be a risk of animal cross-infection if the sampled gas is returned to the breathing system

---

## 9.4 Make AG Settings

By selecting the  key and then [General] tab → [AG Setup] menu, you can make AG settings described below.

### 9.4.1 Set Flow Rate

1. Access  key → [General] tab → [AG Setup] menu.
2. Select [Flow Rate] menu, and then select either: [High], [Med] or [Low].
  - ◆ High: 200 mL/min for high volume watertrap; 120 mL/min for low volume watertrap
  - ◆ Med: 180 mL/min for high volume watertrap; 110 mL/min for low volume watertrap
  - ◆ Low: 150 mL/min for high volume watertrap; 100 mL/min for low volume watertrap
3. Select the [Accept] button to confirm the change.

---



### WARNING

- Please consider the animal's actual beathing capability and select the appropriate pump rate when setting the pump rate.
-

---

## 9.4.2 Set Operating Mode

The default operating mode of the AG module is **[Measure]** when the anesthesia machine is turned on. If the system enters the Standby mode, the CO<sub>2</sub> module will also enter the Standby mode. If the system exits the Standby mode, the CO<sub>2</sub> module will also exit the Standby mode and enter the measure mode.

If the current AG module is in Standby mode, you must push the / key or select the

 key → **[General]** tab → **[AG Setup]** menu → **[Operating Mode]** → **[Measure]** to start the AG module. When the anesthesia machine restarts, the AG module automatically continues with the previously selected operating mode.

When **[Operating Mode]** is set to **[Measure]**, the message **[AG Startup]** appears on the screen. After start-up is finished, the message **[AG Warmup]** is displayed. The AG module is in ISO accuracy mode. After warm-up is finished, the AG module enters full accuracy mode.

## 9.4.3 Set CO<sub>2</sub> Unit

1. Select  key → **[System]** tab.
2. Select the **[Unit]** button → **[CO<sub>2</sub>]** button.
3. Choose **[mmHg]** or **[kPa]** or **[%]**.
4. Select the **[Accept]** button to confirm the change.

## 9.4.4 Gas Scale

1. Select  key → **[Display]** Tab.
2. Select the **[Gas Scale]** button.
3. Select the **[CO<sub>2</sub> Scale]**, **[AA Scale]**, **[O<sub>2</sub> Scale]** or **[N<sub>2</sub>O Scale]** button. If one anesthesia agent, such as Sevoflurane, is detected, the system displays Sev Scale instead of AA Scale.
4. Select the desired scale setting.
5. If needed, select the **[Load Scales Defaults]** button and then select the **[Yes]** button to restore the factory default configurations.
6. Select the **[Accept]** button to confirm the change, or select **[Cancel]** button to discard the change.

---

## 9.4.5 CO<sub>2</sub> Placement

1. Select  key → [Display] Tab.
2. Select the [CO<sub>2</sub> Placement] button.
3. Choose between [TOP] and [Bottom].
4. Select the [Accept] button to confirm the change, or select [Cancel] button to discard the change.

## 9.5 Change Anesthetic Agent

If you change to another anesthetic agent, the AG module is capable of detecting the gas mixture during the transition period. The time required for anesthetic agent changeover depends upon the type of anesthesia (low flow or high flow) and the features of the anesthetic agents used (pharmacokinetics). During the changeover, the anesthesia machine gives no prompt message and the MAC values displayed may be inaccurate.

The AG module can identify two anesthetic agents automatically. When the proportion of the primary and secondary anesthetic agents in the mixture changes, the AG module can distinguish between them according to their contributions to the MAC value. Then the primary and secondary anesthetic agents will be exchanged on a display.

## 9.6 Measurement Limitations

Measurement accuracy may degrade due to:

- Leakage or internal leakage of the sample gas.
- Mechanical shock
- Breathing circuit pressure which is greater than 10 kPa (100 cmH<sub>2</sub>O)
- Other interference source (if present)
- Humidity or condensates

Measurement accuracy may be affected by the breath rate and I/E ratio as follows:

EtCO<sub>2</sub> is within specification for breath rate  $\leq$  60 bpm and I/E ratio  $\leq$  1:1;

EtCO<sub>2</sub> is within specification for breath rate  $\leq$  30 bpm and I/E ratio  $\leq$  2:1.

Measurement accuracy is unspecified for breath rate larger than 60 bpm.

---

## 9.7 Troubleshooting

If the gas inlet (including watertrap, sampling tube and airway adapter) is occluded by condensed water, airway occlusion will be prompted on the screen.

To remove the occlusion:

- Check the airway adapter for occlusion and replace if necessary.
- Check the sampling tube for occlusion or kinking and replace if necessary.
- Check the watertrap for water build-up. Empty the watertrap. If the problem persists, replace the watertrap.

If the problem persists, internal occlusions may exist. Contact your service personnel.

## 9.8 Scavenge the Sample Gas

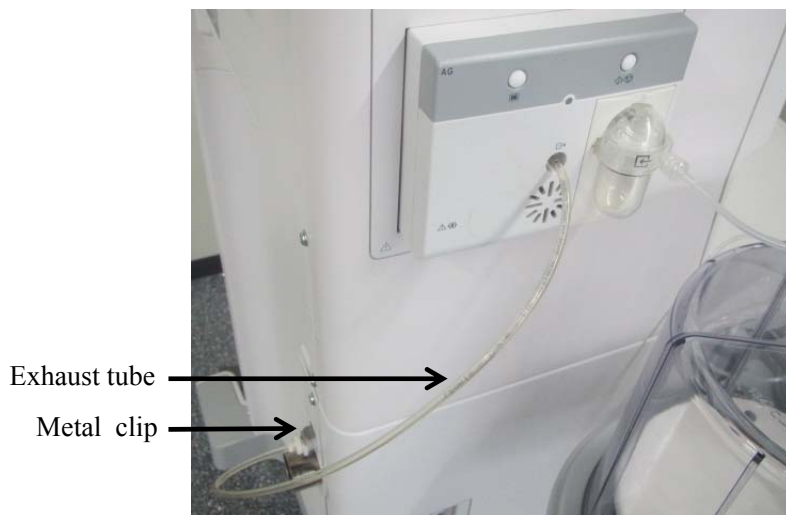

To scavenge the sample gas to the waste gas disposal system, depress the metal clip and then insert the connector of the exhaust tube into the sample gas return port marked . A click indicates that the connector of the exhaust tube is installed in place, as shown above.

Depress the metal clip to bounce the connector of the exhaust tube. Then pull out the connector to remove the exhaust tube.

---

### **WARNING**

- **When using the AG module to perform AG measurements on the animals who are receiving or have recently received anesthetic agents, connect the outlet to the waste gas disposal system to prevent the medical staff from breathing in the anesthetic agents.**
-

---

## 9.9 Calibrate the AG Module

Calibrate the AG module once a year or when the measured value has a great deviation.  
Contact us for calibration service.

### NOTE

- 
- **Advice on the proper disposal of calibration gases refer to chapter 9.8 Scavenge the Sample Gas.**
-

# 10 Alarms

---

---

## 10.1 Introduction

Alarms, triggered by a vital sign that appears abnormal or by technical problems of the anesthesia machine, are indicated to the user by visual and audible alarm indications.

### NOTE

---

- **The System performs a self-test of its alarm system when powered on. The self-test includes the alarm LED and speaker. During the self-test, the alarm LED will illuminate in sequence the colors red, yellow, and cyan for approximately 1 second each color. The system speaker will produce one tone after the alarm light is in self-test.**
  - **The auditory alarm signal A-weighted sound pressure level is within 45 to 85 dB.**
  - **When multiple alarms of different levels occur simultaneously, the anesthesia machine will select the alarm of the highest level and give visual and audible alarm indications accordingly.**
  - **When multiple alarms of same levels occur simultaneously, the alarm messages are displayed in order of time of occurrence.**
- 

### 10.1.1 Types of Alarms and Messages

By nature, the anesthesia machine's alarms fall into three categories: physiological alarms, technical alarms and prompt messages.

#### 1. Physiological alarms

Physiological alarms, also called animal status alarms, are triggered by a monitored parameter value that violates set alarm limits or an abnormal animal condition.

Physiological alarm messages are displayed in the physiological alarm area.

#### 2. Technical alarms

Technical alarms, also called system status alarms, are triggered by a device malfunction or a animal data distortion due to proper operation or mechanical problems. Technical alarm messages are displayed in the technical alarm area.







#### 3. Prompt messages

As a matter of fact, prompt messages are not alarm messages. Apart from the physiological and technical alarm messages, the anesthesia machine will show some messages telling the system status. Messages of this kind are included into the prompt message category and usually displayed in the prompt message area.

## 10.1.2 Alarm Indicators

The system provides the following alarm indicators:

- **An alarm LED located on top of the LCD monitor.** The LED can illuminate red, yellow, cyan, or OFF depending on the alarm condition. The following table describes the alarm behavior of different alarm types and different alarm priority labels. If multiple alarms occur simultaneously, the audio and LED behavior will follow the highest priority active alarm.
- **Colored alarm messages displayed on the Main Screen.** High priority messages are red. Medium priority messages are yellow. Low priority messages are cyan. Prompt messages are white. Messages are displayed according to priority and time.
- **Alarm audio through the system alarm speaker.** The following table lists the audio behavior for each type of alarm.

Alarm Type	Alarm Priority	Audio Behavior	Message Behavior	Alarm LED Color
Physiological Alarm	High	Play high priority alarm sound file, the interval between each play is $5 \pm 1$ s.	White text red background, high priority icon 	Red
	Medium	Play medium priority alarm sound file, the interval between each play is $5 \pm 1$ s.	Black text yellow background, medium priority icon 	Yellow
	Low	Play low priority alarm sound file, the interval between each play is $17 \pm 1$ s.	White text cyan background, low priority icon 	Cyan
Technical Alarm	High	Play high priority alarm sound file, the interval between each play is $5 \pm 1$ s.	White text red background, high priority icon 	Red
	Medium	Play medium priority alarm sound file, the interval between each play is $5 \pm 1$ s.	Black text yellow background, medium priority icon 	Yellow
	Low	Play low priority alarm sound file, the interval between each play is $17 \pm 1$ s.	White text cyan background, low priority icon 	Cyan
Prompt Message	None	None	Black text white background	Off



---

## 10.2 Display Alarms

On the LCD monitor screen, alarm messages are automatically displayed at the top area of the Main Screen when alarm conditions occur. Additionally, a list of all active alarms and an alarm log can be found in the **[Alarms]** window.

Each message is displayed with an associated priority symbol as follows:

- High priority:     △!!!
- Medium priority:   △!!
- Low priority:      △!

To display a list of all active alarms:

1. On the Main Screen, select the  key or touch the Alarm Message area at the top of the screen.

The **[Alarms]** window is displayed.

2. Select the **[Active]** tab.

A list of all active alarm messages is displayed. Alarms are displayed in order of priority and time.

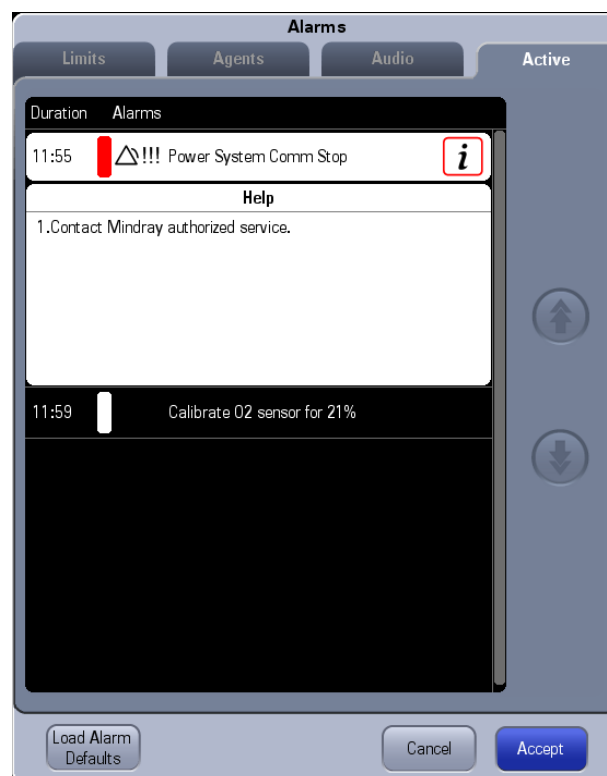

---

## NOTE

---

- Only high priority alarms offer help information.
  - Active alarms are ordered by alarm priority and time. The most recent and highest alarm is shown first.
- 

### 10.3 Displayed Order of Alarm Messages

Alarm messages are displayed in order of priority and time of occurrence. The alarm messages list divided into two areas.

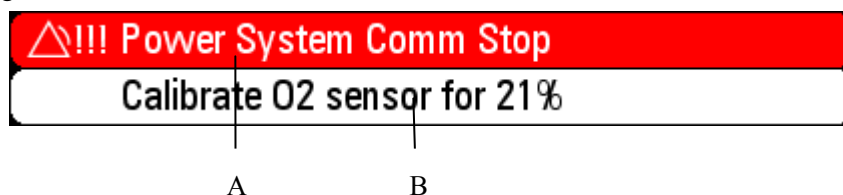

A: Area A (Highest priority and most recent alarm)

B: Area B (Less priority or less recent alarms)

- To be in Area A, an alarm must be both the highest priority and the most recent (Area A does not cycle). The remaining active alarms and prompt messages cycle in Area B.
- New Alarms with less priority than alarms in Area A are displayed immediately in Area B, and the cycle proceeds from that position in the list.
- Alarms cycling in Area B are grouped and displayed in the following order: high priority, medium priority, low priority, and prompt messages. In each group, the most recent alarm is displayed first.
- If the alarm in Area A is removed, then the most recent and highest priority alarm from Area B is moved to Area A.

### 10.4 Set Alarm Volume



Users can set the audio level of alarms and system alerts by selecting the  key on the Main Screen to display the [Alarms] window.

The [Alarms] volume settings adjust the audio level of all high, medium, and low Priority sounding alarms. The [System Alerts] volume settings adjust the audio level of all sounding pop-up prompts and non-confirmed ventilation mode alerts.

The adjustable volume range is within 45 to 85dB which is recommended by IEC 60601-1-8.

---

To set the Alarm Volume:

1. On the Main Screen, select the  key.  
The [Alarms] window is displayed.
2. Select the [Audio] tab.  
Volume controls for [Alarms] and [System Alerts] are displayed.
3. Adjust the volume by selecting the  (increase) or  (decrease) buttons.
  - ◆ The Alarms volume has 10 levels of adjustment. Default level is 5.
  - ◆ The System Alerts volume has 10 levels of adjustment. Default level is 2.
4. Select [Accept] button to activate your changes and exit the [Alarms] window.  
(Selecting [Cancel] button will discard your changes and exit the [Alarms] window.)

---

## WARNING

- Do not rely exclusively on the audible alarm system when using the anesthesia machine. Adjustment of alarm volume to a low level may result in a hazard to the animal. Always keep the animal under close surveillance.
- 

## 10.5 Set Alarm Limits



### NOTE

- An alarm is triggered when the parameter value is higher than the [High Limit] or lower than the [Low Limit]. The background of this parameter flashes. Click the flashing parameter to open the [Alarms] menu, to set the alarm limit quickly.
  - When using the anesthesia machine, always keep an eye to whether the alarm limits of a specific parameter are set to the appropriate values.
  - Set ALARM LIMITS to extreme values can render the ALARM SYSTEM useless.
  - When the machine is powered on after system power is off, the configuration to be loaded should be determined according to the power off duration. If the power off duration is equal to or longer than 120 seconds then the user default configurations should be loaded into Current configurations. If the power off duration is equal to or shorter than 60 seconds then the latest configurations should be loaded into the Current configurations. When the anesthesia machine is powered on 60 seconds to 120 seconds after the previous power-off, either the latest current configuration or the user default configuration may be loaded. This is unspecified due to precision error of power-off duration saved in the system.
-

---

## 10.5.1 Set Ventilator Alarm Limits

Users can set the alarm limits of Paw, MV, Vt Exp, Rate, FiO<sub>2</sub>, EtO<sub>2</sub>, FiN<sub>2</sub>O, EtN<sub>2</sub>O, FiCO<sub>2</sub> and EtCO<sub>2</sub> to create alarm conditions consistent with animal needs. The alarm is then triggered when the parameter value is greater than the High Limit or lesser than the Low Limit.

1. On the Main Screen, select the  key.  
The [**Alarms**] window is displayed.
2. Select the [**Limits**] tab or [**Agents**] tab.
3. Select a parameter softkey. The softkey is highlighted when selected.
4. Use the on-screen keypad to enter the desired parameter value, or press down the   
or  button to increase or decrease the parameter value, or turn the control knob to set the value. For each parameter, the range of values is displayed above the keypad.
5. Optionally, to restore the default values, select the [**Load Alarm Defaults**] button. This restores the high and low values for the parameters to the user default values.
6. Repeat Steps 3 and 4 for each parameter value.
7. Select [**Accept**] button to save the change (or select [**Cancel**] button to not save).

## 10.5.2 Set CO<sub>2</sub> Alarm Limits

1. On the Main Screen, select the  key → [**Limits**] tab.
2. Set [**High Limit**] and [**Low Limit**] respectively for each parameter.
3. Select [**Accept**] button to save the change (or select [**Cancel**] button to not save).

## 10.5.3 Set AG Alarm Limits

1. On the Main Screen, select the  key → [**Agent**] tab.
2. Set [**High**] and [**Low**] respectively for each parameter.
3. Select [**Accept**] button to save the change (or select [**Cancel**] button to not save).

---

## 10.5.4 Auto Alarm Limits

The Auto Alarm Limits function uses an algorithm based on measured values. The relationship is shown in the table below.

The [**Auto Alarm Limits**] button is disabled when the system is in Standby mode, Manual mode or Monitor mode. The [**Auto Alarm Limits**] button is also disabled when the current mode is PS, SIMV-VC, or SIMV-PC.

Alarm Limit	Adjust Formula
Paw High	PEAK+5 or PLAT+10, whichever is greater minimum 35 cmH <sub>2</sub> O
Paw Low	$(\text{PLAT} - \text{PEEP}) \times 0.6 + \text{PEEP} - 1$ minimum 3 cmH <sub>2</sub> O maximum Paw High - 1
MV High	$\text{MV} \times 1.4$ minimum 2.0 L/min
MV Low	$\text{MV} \times 0.6$ minimum 0.3 L/min maximum MV High - 0.1
Vt Exp High	$\text{Vt Exp} \times 1.4$ maximum 1600 mL
Vt Exp Low	$\text{Vt Exp} \times 0.6$ minimum 0 mL
Rate High	$\text{Rate} \times 1.4$ maximum 100 bpm
Rate Low	$\text{Rate} \times 0.6$ minimum 2 bpm

The parameters in the formula are all measured parameters. The new alarm limits for Paw are calculated on the basis of average values for PEAK, PLAT, and PEEP. The value used for average uses the value of the last four ventilation cycles or the value in one minute, whichever is smaller. Spontaneous breaths by the animal are not taken into account.

If there is not a valid measured MV, the corresponding MV alarm limits will not be adjusted.

If the average value for PEAK, PLAT, and PEEP cannot be calculated, the corresponding alarm limits will not be adjusted.



If the calculated alarm limit is more than the high threshold of setting range or less than the low threshold, the corresponding threshold is used as the auto alarm limit.

---

## 10.6 Alarm Audio Pause

### 10.6.1 Set Alarm Audio Pause



When an alarm condition occurs and the alarm audio is heard, the user can select the  key to pause the alarm audio. In audio paused status, all the alarm indicators work normally except audible alarm tones.

Select  key to pause all currently sounding alarm tones. The icon on the left of the alarm message changes to . It indicates the alarm audio has been paused. The alarm audio pause icon  and 120 s countdown time appear at the top of the screen.

#### NOTE

- 
- **The alarm audio will be heard, if an alarm condition occurs when the system is in an audio-paused state. Select  key, the new alarm audio will be paused for 120 s.**
  - **When the 120 s countdown time is up, the 120 s alarm audio pause status will be finished and audible alarm tones restored.**
- 

### 10.6.2 Cancel Alarm Audio Pause

In the alarm audio pause status, pressing  key or triggering a new alarm will finish the current audio pause status and restore audible alarm tones. Besides, the alarm audio pause icon  and 120 s countdown time will disappear from the upper right corner of the screen.

---

## 10.7 When an Alarm Occurs

When an alarm occurs, do as follows:

1. Check the animal's condition.
2. Determine the alarming parameter or alarm category.
3. Identify the alarm source.
4. Take proper actions to eliminate the alarm condition.
5. Ensure the alarm condition is corrected.

For details about how to troubleshoot alarms, refer to *D Alarm and Prompt Messages*.

---

**FOR YOUR NOTES**



# 11 Installations and Connections

---

---

## WARNING

---

- Continuous use of desiccated absorbent may endanger animal safety. Adequate precautions should be taken to ensure that the absorbent in the CO<sub>2</sub> absorbent canister does not become desiccated. Turn off all gases when finished using the system.
  - When electrosurgical equipment is used, keep the electrosurgical leads away from the breathing system, the O<sub>2</sub> sensor and other parts of the anesthesia machine. Keep backup manual ventilation and simple respirator with mask available in case the electrosurgical equipment prevents safe use of the ventilator. In addition, make sure of the correct operations of all life support and monitoring equipment.
  - Do not use antistatic or conductive masks or breathing tubes. They can cause burns if they are used near high frequency electrosurgical equipment.
  - This equipment must be installed by the factory authorized engineer.
  - This anesthesia machine has waste gas exhaust ports. The operator of the machine should pay attention to the disposal of the residual breathing gas scavenged.
- 

## CAUTION

---

- The operational environment and the power source of the equipment shall comply with the requirements in B.2 Environmental Specifications and B.3 Power Requirements.
- 

## 11.1 Install the Breathing System

The anesthesia machine can be configured with two types of breathing systems. Here, breathing system compatible with Pre-Pak and that not compatible with Pre-Pak are defined.

### NOTE

---

- Pay attention to the disposal of the breathing circuit after equipment use, the detection of the absorbent in the canister and the anesthetic agent in the vaporizer to ensure the normal operation of the equipment.
-

---

## 11.1.1 Breathing System Compatible with Pre-Pak

### 11.1.1.1 Breathing System Diagrams

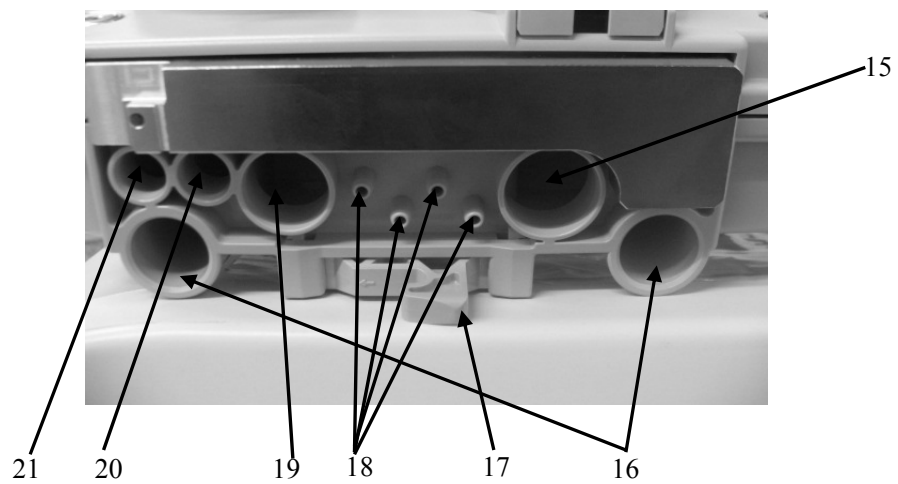
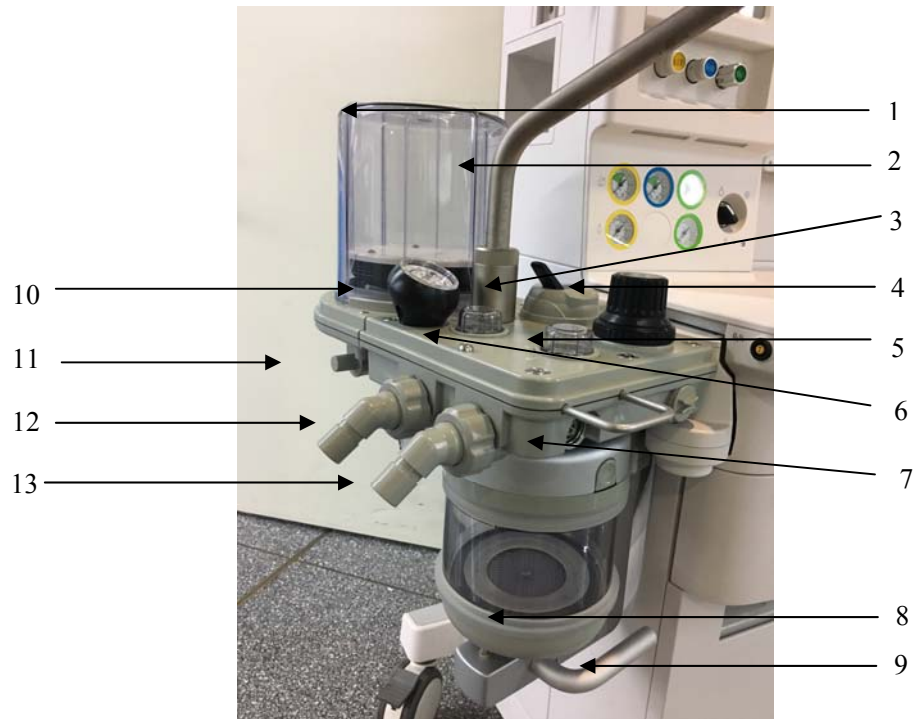

1	Bellows housing	12	Expiration connector
2	Bag arm	13	Inspiration connector
3	Auto/Manual switch	14	Water collection cup
4	APL valve	15	Drive gas connector
5	Inspiratory check valve	16	Guide pin hole
6	Expiratory check valve	17	Locking catch retainer
7	O <sub>2</sub> sensor	18	Pressure sampling connector
8	CO <sub>2</sub> absorbent canister	19	APL valve gas outlet
9	Handle for CO <sub>2</sub> absorbent canister	20	Fresh gas inlet
10	Airway pressure gauge	21	ACGO connector
11	Leak test plug	/	/

### 11.1.1.2 Circuit Adapter Diagram

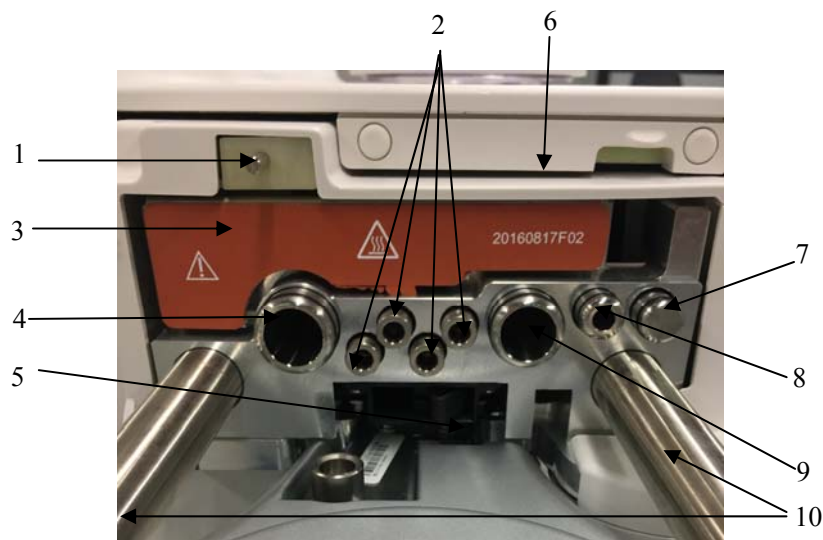

1	Auto/Manual ventilation linked switch	6	Circuit adapter base
2	Pressure sampling connector	7	ACGO connector
3	Heating module	8	Fresh gas inlet
4	Drive gas connector	9	APL valve gas outlet
5	Circuit switch	10	Circuit support guide

### NOTE

- The heating module does not work when the anesthesia machine is battery powered.
- Do not overbear the bag arm, such as depressing it forcibly or hanging heavy objects onto it.
- When the difference between the reading on the airway pressure gauge and the Paw value displayed on the screen is great, please contact us.

---

### 11.1.1.3 Install the Breathing system

1. Align the guide pin holes on the circuit block with the matching guide pins on the circuit adapter.



2. Push the breathing system into the circuit adapter with force to allow the breathing system to be connected to the adapter seamlessly.



3. Lock the breathing system. Refer to *11.1.1.8 Install the CO<sub>2</sub> Absorbent Canister* for operation steps. The process of installing the CO<sub>2</sub> absorbent canister is the process of locking the breathing system.

---

### **WARNING**

- **After the breathing system is installed onto the circuit adapter, ensure that the breathing system is firmly locked. If not, the breathing system will be disconnected from the circuit adapter during use, which can cause serious fresh gas leak and inaccurate tidal volume measurement.**
-

---

## NOTE

---

- If it is hard to push the breathing system into or out of the circuit adapter, you need to apply some lubricant (M6F-02003---: “DuPont Krytox high-performance fluorine lubricating grease”) to the seal on the pneumatic connector to reduce friction.
- 

### 11.1.1.4 Install the Bag Arm

1. Align the bag arm with the port on the breathing system.



2. Turn the locking nut clockwise to tighten the bag arm.



---

### 11.1.1.5 Install the Bellows

---

#### **WARNING**

---

- **Before installing the bellows housing, check that the sealing component on the breathing system is in position. If not, you must install the sealing component properly before installing the bellows housing.**
- 

1. Attach the bottom ring of the bellows to the bellows base on the breathing system and ensure that the bellows is tightly connected to the base.

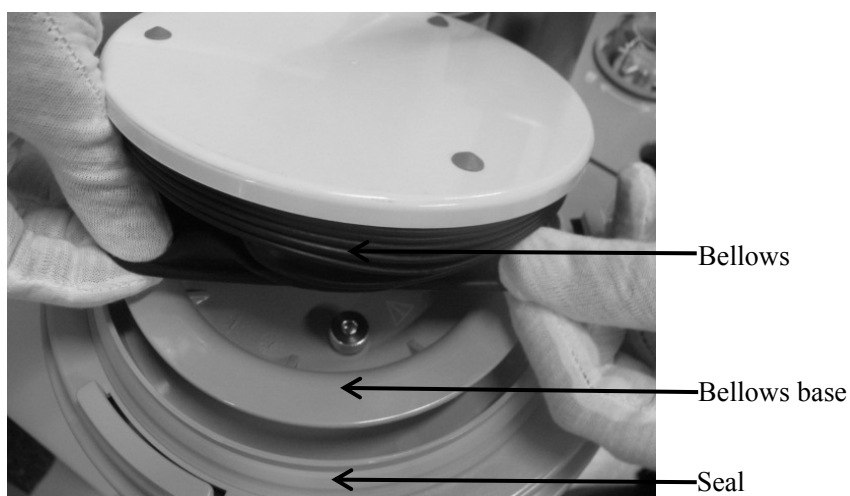

2. Align the bellows housing bayonet tabs with the slots on the breathing system and then lower the bellows housing. Ensure that the housing is depressing the seal evenly.

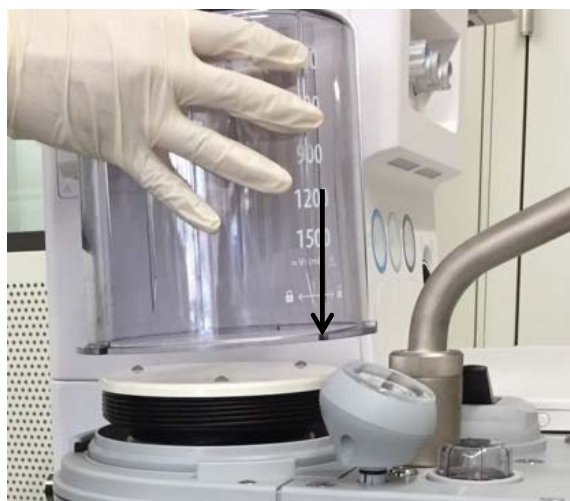

- 
3. Hold the bellows housing tightly and turn it clockwise until it stops. Ensure that the side of the housing marked with scale is facing the operator.



#### 11.1.1.6 Install the Flow Sensor

---

#### WARNING

---

- **Tighten the locking nuts when installing the flow sensor. Failure to do so may result in invalid measurement.**
- **Exert care when moving the anesthesia machine to prevent the flow sensor from getting damaged.**
- **The end of inspiration/expiration connectors which connects the breathing tube shall be kept downward to prevent condensed water from entering the breathing system.**

- 
1. Ensure that the direction of arrow on the flow sensor is same to that on the breathing system and the side with printed illustration is facing upward.





- 
2. Insert the flow sensor horizontally.
  3. Align the inspiration/expiration connectors and their locking nuts with the flow sensors.



4. Tighten the locking nuts clockwise.



#### 11.1.1.7 Install the O<sub>2</sub> Sensor

---

### **WARNING**

---

- Before installing the O<sub>2</sub> sensor, check that the seal on the sensor is in good condition. If no seal is installed or the seal is damaged, replace the O<sub>2</sub> sensor.
  - When installing the O<sub>2</sub> sensor, turn it tightly to avoid breathing system leak.
  - Install the O<sub>2</sub> sensor manually. Using a wrench or other tool may damage the O<sub>2</sub> sensor.
-



---

## NOTE

---

- Before installing the O<sub>2</sub> sensor, please check if the hexagon nut shown below is screwed tightly. If not, it may cause the O<sub>2</sub> sensor connection failure.

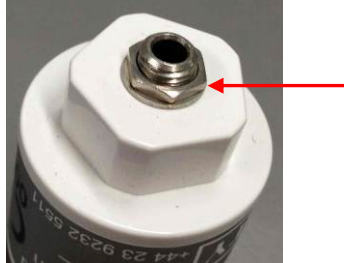

1. Rotate the O<sub>2</sub> sensor into the O<sub>2</sub> sensor shell. Then tighten the O<sub>2</sub> sensor cable onto the O<sub>2</sub> sensor shell.



The O<sub>2</sub> sensor assembly installed in place is shown below.



- 
2. Insert the O<sub>2</sub> sensor assembly into the O<sub>2</sub> sensor port on the breathing system.



3. Insert the other end of the O<sub>2</sub> sensor cable into the O<sub>2</sub> sensor port on the circuit adapter.



---

### 11.1.1.8 Install the CO<sub>2</sub> Absorbent Canister

---

#### **WARNING**

---

- Obey applicable safety precautions.
  - Do not use the CO<sub>2</sub> absorbent canister with chloroform or trichloroethylene.
  - Disposable CO<sub>2</sub> absorbent canister is a sealed unit which should not be opened or refilled.
  - Avoid skin or eye contact with the contents of the CO<sub>2</sub> absorbent canister. In the event of skin or eye contact, immediately rinse the affected area with water and seek medical assistance.
  - Changing the absorbent during ventilation may result in breathing system leakage if the anesthesia machine does not have BYPASS function.
  - When the anesthesia machine is configured with BYPASS function, ensure that the CO<sub>2</sub> absorbent canister is installed in position and is locked tight. Failure to do so causes the gas inside the breathing system to bypass the CO<sub>2</sub> absorbent canister, resulting in repeated inhalation of the animal's exhaled CO<sub>2</sub>.
  - CO<sub>2</sub> concentration monitoring is strongly recommended when the anesthesia machine has BYPASS function.
  - Before installing a CO<sub>2</sub> absorbent canister, inspect the color of the absorbent in the canister to determine when to change the absorbent.
  - Inspect absorbent color during the surgery or at the end of a case. During non-use, absorbent may go back to the original color. Refer to the absorbent instructions for more information about color changes.
  - Adequate precautions should be taken to ensure that the absorbent in the CO<sub>2</sub> absorbent canister does not become desiccated. Turn off all gases every time when finished using the system. If the absorbent completely dries out, it may give off carbon monoxide (CO) when exposed to anesthesia agents. For safety, replace the absorbent.
  - Clean the CO<sub>2</sub> absorbent canister and change the CO<sub>2</sub> absorbent canister sponge regularly. Otherwise, the absorbent powder built up inside the CO<sub>2</sub> absorbent canister will go into the breathing system.
  - Clean the rim of the CO<sub>2</sub> absorbent canister regularly. Absorbent particles sticking on the rim may cause breathing system leak.
  - Before installing the CO<sub>2</sub> absorbent canister, inspect the canister rim, canister support and seal for absorbent particles. If there is, clean it to prevent breathing system leakage.
  - Check if the CO<sub>2</sub> absorbent canister is installed in place. If not, the alarm message of [CO<sub>2</sub> Canister Not Mounted] is displayed on the screen. In this case, push the
-

---

---

## WARNING

---

Audio Pause key and a dialog box pops up prompting [Are you sure you want to disable the "CO<sub>2</sub> Canister Not Mounted" alarm for more than 2 minutes? ]. This alarm message changes to prompt message when [Ok] is selected.

- After replacing the CO<sub>2</sub> absorbent or mounting CO<sub>2</sub> absorber, ensure that CO<sub>2</sub> can be fully absorbed by the absorbent.
- 

## NOTE

---

- The CO<sub>2</sub> absorbent canister should only be used with air, oxygen, nitrous oxide, Halothane, Enflurane, Isoflurane, Sevoflurane and Desflurane.
  - Change absorbent when necessary to prevent the build-up of non-metabolic gases when the system is not in use.
  - Before installing the CO<sub>2</sub> absorbent canister, check that the seal between the breathing system and the CO<sub>2</sub> absorbent canister is in good condition. If not, replace the seal immediately.
  - When absorber is on, all gases will pass through the absorbent.
- 

### Assemble the CO<sub>2</sub> Absorbent Canister

1. Connect the tube of the CO<sub>2</sub> absorbent canister to the base assembly of the CO<sub>2</sub> absorbent canister.

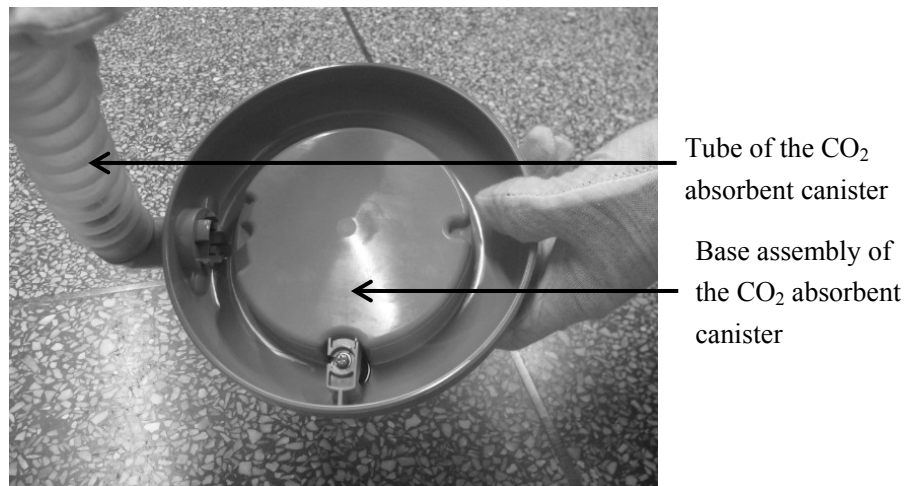

- 
2. Connect the other end of the tube of the CO<sub>2</sub> absorbent assembly to the Bypass assembly.

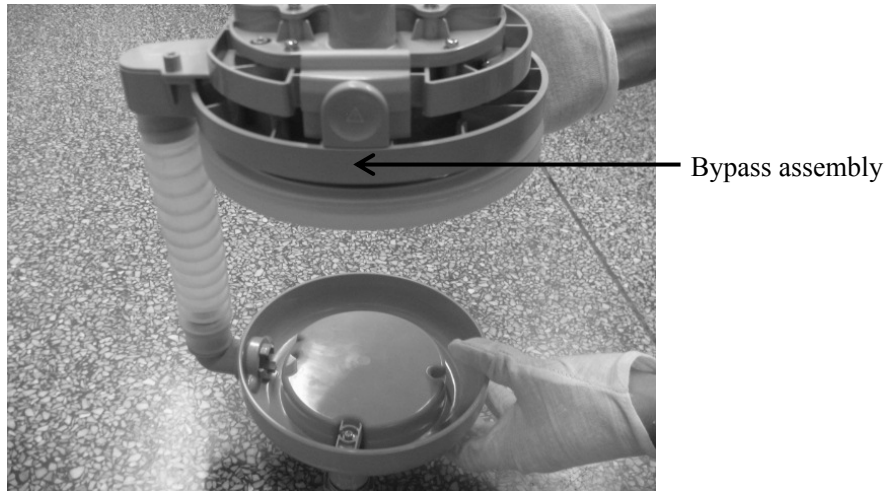

3. Slide the guide rod on the base assembly of the CO<sub>2</sub> absorbent canister into the guide hole.

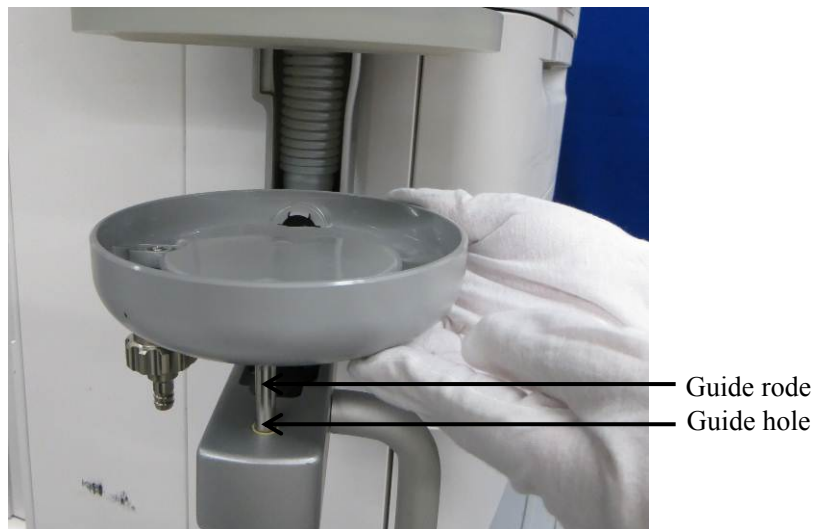

- 
4. Press and hold the buckle on the Bypass assembly and align it with the Bypass mounting plate to mount the Bypass assembly in position.



- 
5. Place the absorbent canister onto the base assembly.

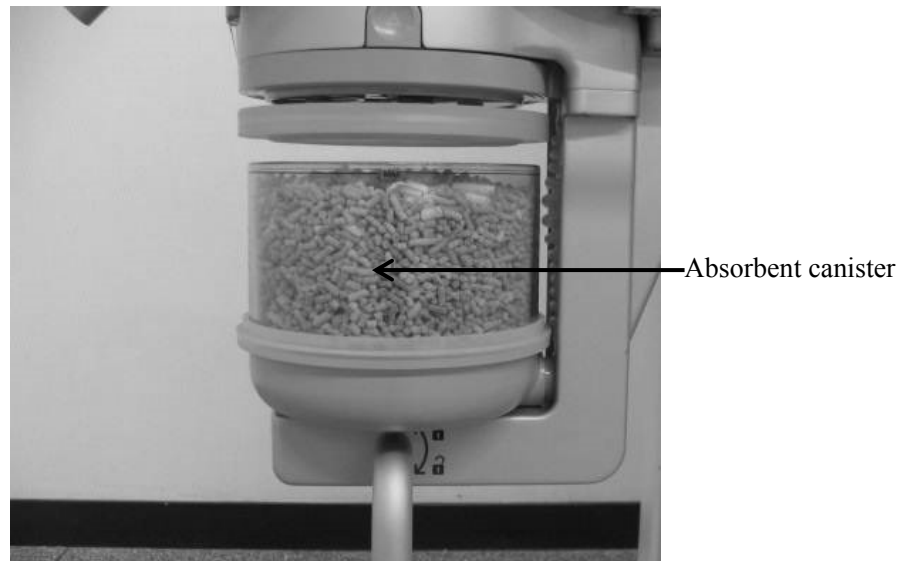

6. Rotate the handle to the position as shown below to lock the absorbent canister and the breathing system as well.



---

**⚠ CAUTION**

- Remember to do a breathing system leak test after reinstalling the CO<sub>2</sub> absorbent canister.
-

---

## Change the Absorbent

### NOTE

- A gradual color change of the absorbent in the canister indicates absorption of carbon dioxide. The color change of the absorbent is only a rough indicator. Use carbon dioxide monitoring to determine when to change the absorbent.
  - Follow local regulations regarding disposal of hospital waste when the absorbent has changed color. If left standing for several hours, it may regain its original color giving a misleading indication of activity.
  - Medisorb™ absorbent is recommended.
- 

1. Rotate the handle to the position as shown below.



2. Remove the absorbent canister.
3. Remove the Pre-Pak absorbent which has changed color or pour out the loose fill absorbent.
4. Change the Pre-Pak absorbent or pour in new loose fill absorbent.

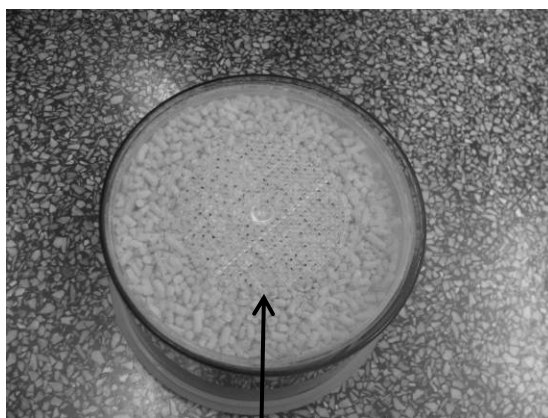

Pre-Pak absorbent

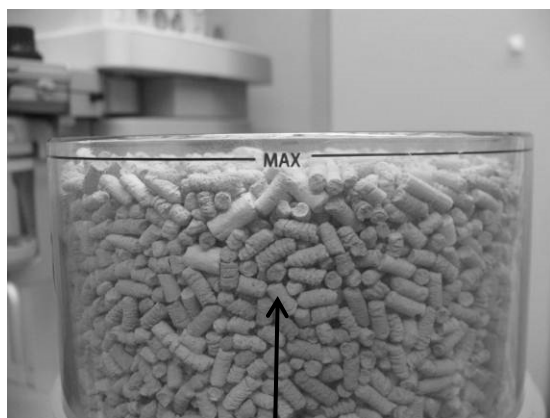

Loose fill absorbent



- 
5. Place the absorbent canister onto the base assembly.

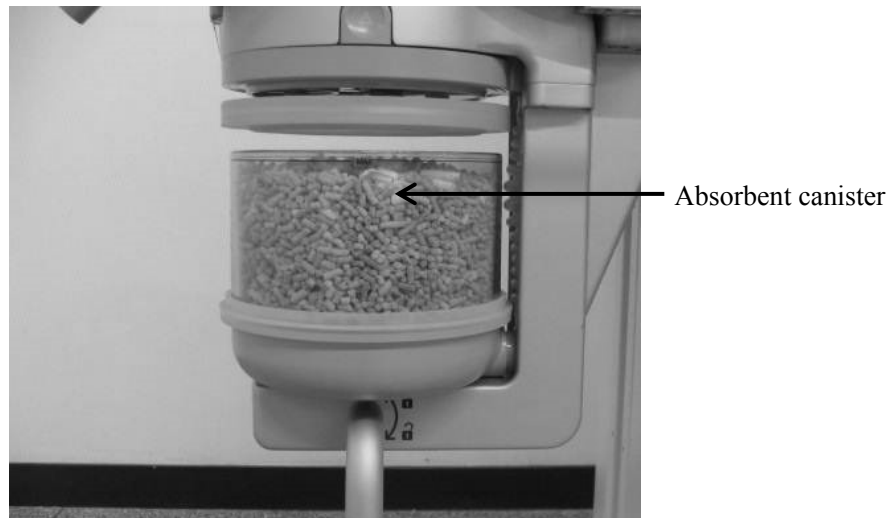

6. Rotate the handle to the position as shown below to lock the absorbent canister and the breathing system as well.

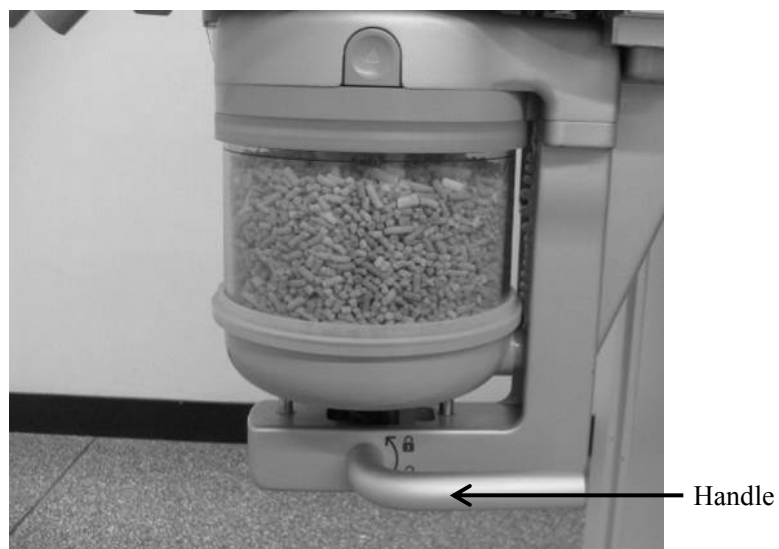

---

**⚠ WARNING**

- When re-installing the CO<sub>2</sub> absorbent canister after changing the absorbent, ensure that the canister is locked firmly and installed in position.

---

**NOTE**

- The absorbent poured in cannot exceed the **MAX** level marked on the CO<sub>2</sub> absorbent canister.

---

### 11.1.1.9 Install the Breathing Tubes

#### NOTE

- When installing the breathing tube, hold the tube connector at both ends of the tube to prevent damage of the tube.
  - Do not reuse the filter to prevent cross-contamination.
  - Install the filter as described in this manual to prevent dust and particles from entering the animal's lungs and prevent cross-contamination.
- 

1. The following picture shows the filter at the animal connection.

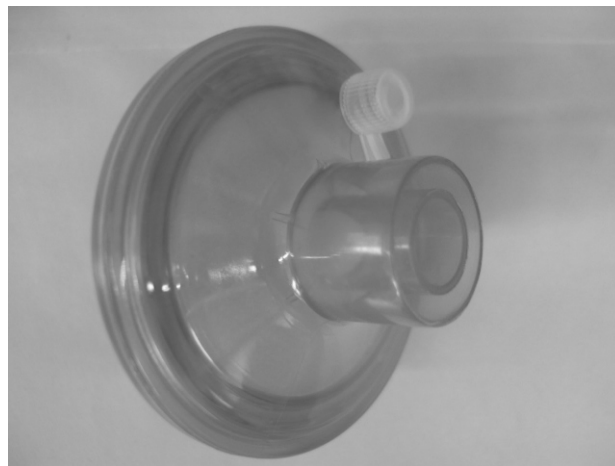

2. Connect the two ends of the breathing tubes to the inspiration/expiration connectors on the breathing system.



- 
3. Connect the filter to the Y-piece.



### 11.1.1.10 Install the Manual Bag

Connect the manual bag to the manual bag port on the breathing system.



---

## 11.1.2 Breathing System Not Compatible with Pre-Pak

### 11.1.2.1 Breathing System Diagrams

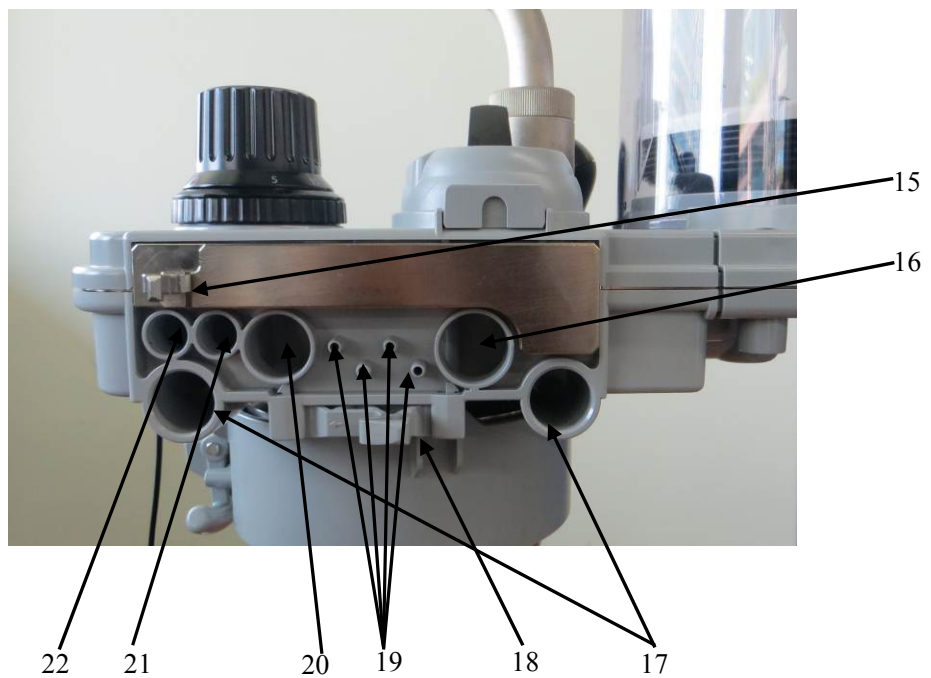
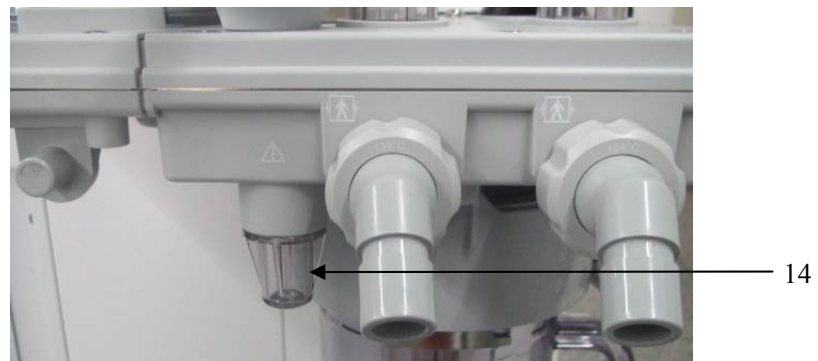
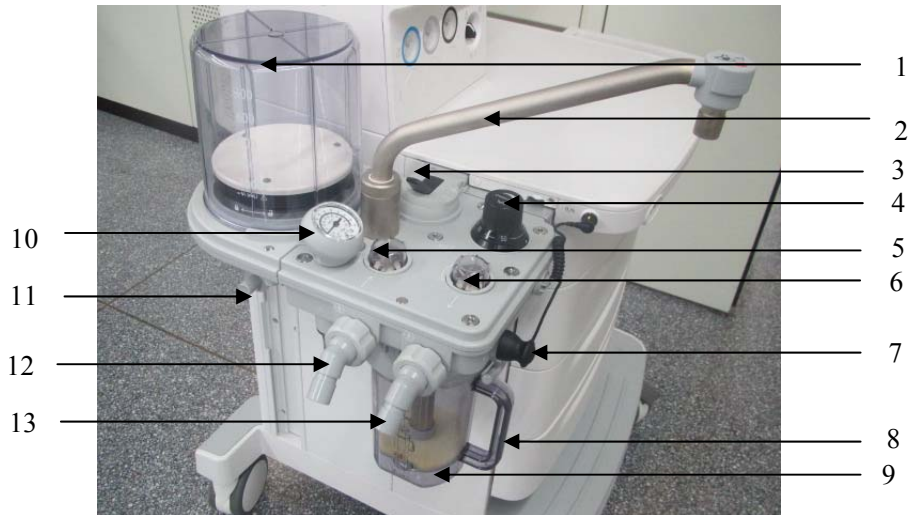

1	Bellows housing	12	Expiration connector
2	Bag arm	13	Inspiration connector
3	Auto/Manual switch	14	Water collection cup
4	APL valve	15	Locking hook
5	Expiratory check valve	16	Drive gas connector
6	Inspiratory check valve	17	Guide pin hole
7	O <sub>2</sub> sensor	18	Locking catch retainer
8	Handle for CO <sub>2</sub> absorbent canister	19	Pressure sampling connector
9	Soda-lime container or CO <sub>2</sub> absorbent canister	20	APL valve gas outlet
10	Airway pressure gauge	21	Fresh gas inlet
11	Leak test plug	22	ACGO connector (if configured)

### 11.1.2.2 Circuit Adapter Diagram

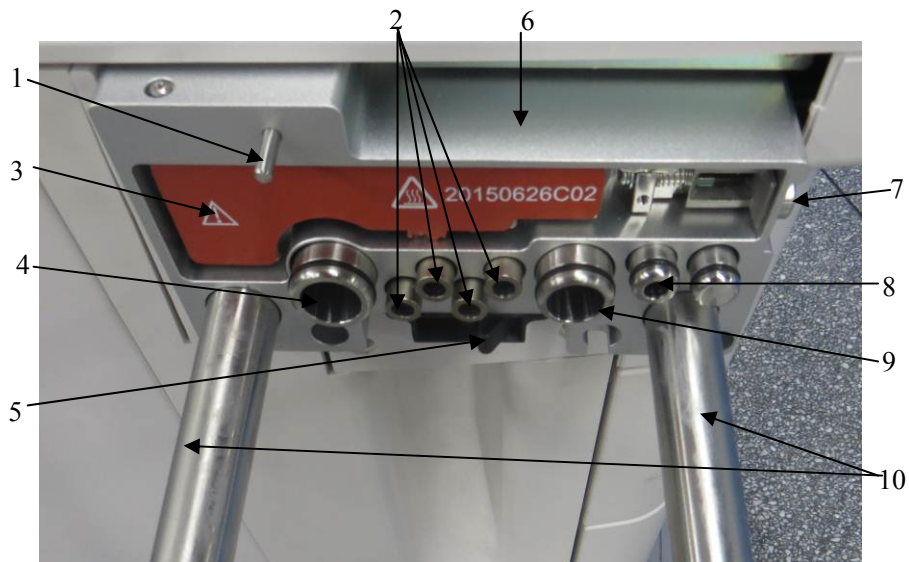

1	Auto/Manual ventilation linked switch	6	Circuit adapter base
2	Pressure sampling connector(s)	7	Locking catch
3	Heating module	8	Fresh gas inlet
4	Drive gas connector	9	APL valve gas outlet
5	Circuit switch	10	Circuit support guide

---

## NOTE

---

- The heating module does not work when the anesthesia machine is battery powered.
  - Do not overload the bag arm, for instance, depress it forcibly or hanging heavy objects onto it.
  - When the difference between the reading on the airway pressure gauge and the Paw value displayed on the screen is high, please contact us.
- 

### 11.1.2.3 Install the Breathing System

1. Align the guide pin holes on the breathing system with the matching guide pins on the circuit adapter.



2. Push the breathing system into the circuit adapter firmly to allow the breathing system to be connected to the adapter seamlessly.

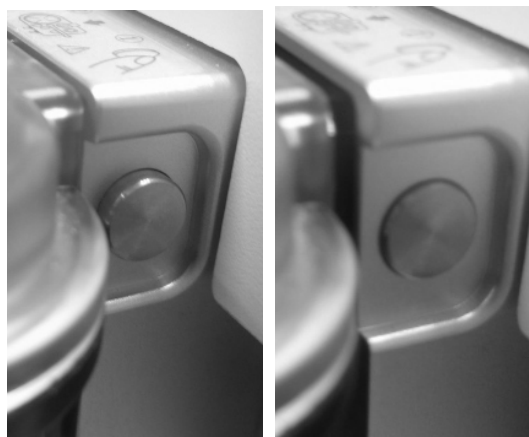

Locked state

Unlocked state

---

---

 **WARNING**

---

- After the breathing system is installed onto the circuit adapter, ensure that the breathing system is firmly locked. If not, the breathing system will be disconnected from the circuit adapter during use, which can cause serious fresh gas leak and inaccurate tidal volume measurement.
- 

**NOTE**

---

- If it is hard to push the breathing system into or out of the circuit adapter, you need to apply some lubricant to the seal on the pneumatic connector (M6F-020003---: “Dupont Krytox high-performance fluorine lubricating grease”) to the seal on the pneumatic connector to reduce friction.
- 

#### 11.1.2.4 Install the Bag Arm

1. Align the bag arm with the port on the breathing system.



2. Turn the locking nut clockwise to tighten the bag arm.





---

### 11.1.2.5 Install the Bellows

---

#### **WARNING**

---

- **Before installing the bellows housing, check that the sealing component on the breathing system is in position. If not, you must install the sealing component properly before installing the bellows housing.**
- 

1. Attach the bottom ring of the bellows to the bellows base on the breathing system and ensure that the bellows is tightly connected to the base.

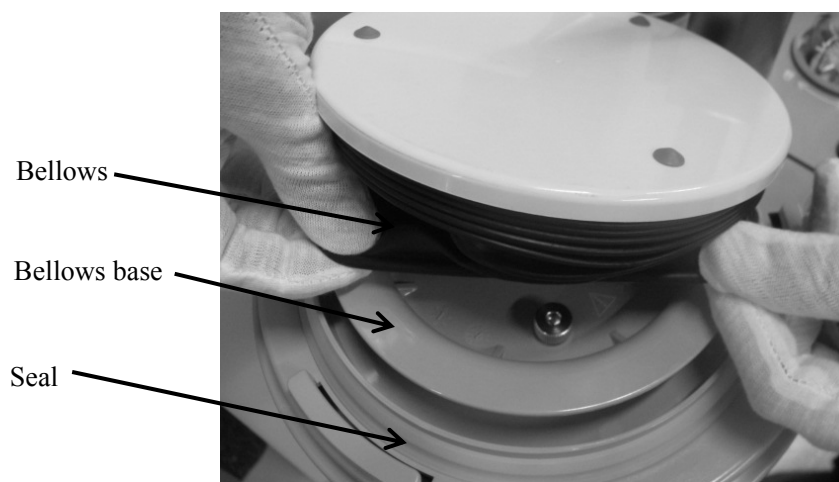

2. Align the bellows housing bayonet tabs with the slots on the breathing system and then lower the bellows housing. Ensure that the housing is depressing the seal evenly.





- 
3. Hold the bellows housing tightly and turn it clockwise until it stops. Ensure that the side of the housing marked with scale is facing the operator.



#### 11.1.2.6 Install the Flow Sensor

---

### WARNING

---

- **Tighten the locking nuts when installing the flow sensor. Failure to do so may result in invalid measurement.**
  - **Exert care when moving the anesthesia machine to prevent the flow sensor from getting damaged.**
  - **The end of inspiration/expiration connectors which connects the breathing tube shall be kept downward to prevent condensed water from entering the breathing system.**
- 

1. Ensure that the direction of arrow on the flow sensor is same to that on the breathing system and the side with printed illustration is facing upward.



- 
2. Insert the flow sensor horizontally.
  3. Align the inspiration/expiration connectors and their locking nuts with the flow sensors.



4. Tighten the locking nuts clockwise.



---

### 11.1.2.7 Install the O<sub>2</sub> Sensor

---

#### WARNING

---

- Before installing the O<sub>2</sub> sensor, check if the seal on the sensor is in good condition. If no seal is installed or the seal is damaged, replace the O<sub>2</sub> sensor.
  - When installing the O<sub>2</sub> sensor, turn it tightly to avoid breathing system leak.
  - Install the O<sub>2</sub> sensor manually. Using a wrench or other tool may damage the O<sub>2</sub> sensor.
- 

#### NOTE

---

- Before installing the O<sub>2</sub> sensor, please check if the hexagon nut shown below is screwed tightly. If not, it may cause the O<sub>2</sub> sensor connection failure.



1. Rotate the O<sub>2</sub> sensor into the O<sub>2</sub> sensor port on the breathing system.



The O<sub>2</sub> sensor assembly is shown below.



- 
2. Insert the O<sub>2</sub> sensor cable into the O<sub>2</sub> sensor.



3. Insert the other end of the O<sub>2</sub> sensor cable into the O<sub>2</sub> sensor connector on the circuit adapter.



---

### 11.1.2.8 Install the Soda-lime container or CO<sub>2</sub> Absorbent Canister

---

#### **WARNING**

---

- Obey applicable safety precautions.
  - Do not use the CO<sub>2</sub> absorbent canister with chloroform or trichloroethylene.
  - Disposable CO<sub>2</sub> absorbent canister is a sealed unit which should not be opened or refilled.
  - Avoid skin or eye contact with the contents of the CO<sub>2</sub> absorbent canister. In the event of skin or eye contact, immediately rinse the affected area with water and seek medical assistance.
  - Changing the absorbent during ventilation may result in breathing system leakage if the anesthesia machine does not have BYPASS function.
  - When the anesthesia machine is configured with BYPASS function, ensure that the CO<sub>2</sub> absorbent canister is installed in position and is locked tight. Failure to do so causes the gas inside the breathing system to bypass the CO<sub>2</sub> absorbent canister, resulting in repeated inhalation of the animal's exhaled CO<sub>2</sub>.
  - CO<sub>2</sub> concentration monitoring is strongly recommended when the anesthesia machine has BYPASS function.
  - Before installing a CO<sub>2</sub> absorbent canister, inspect the color of the absorbent in the canister to determine when to change the absorbent.
  - Inspect absorbent color during the surgery or at the end of a case. During non-use, absorbent may go back to the original color. Refer to the absorbent instructions for more information about color changes.
  - Adequate precautions should be taken to ensure that the absorbent in the CO<sub>2</sub> absorbent canister does not become desiccated. Turn off all gases every time when finished using the system. If the absorbent completely dries out, it may give off carbon monoxide (CO) when exposed to anesthesia agents. For safety, replace the absorbent.
  - Clean the CO<sub>2</sub> absorbent canister and change the CO<sub>2</sub> absorbent canister sponge regularly. Otherwise, the absorbent powder built up inside the CO<sub>2</sub> absorbent canister will go into the breathing system.
  - Clean the rim of the CO<sub>2</sub> absorbent canister regularly. Absorbent particles sticking on the rim may cause breathing system leak.
  - Before installing the CO<sub>2</sub> absorbent canister, inspect the canister rim, canister support and seal for absorbent particles. If there is, clean it to prevent breathing system leakage.
  - Check if the CO<sub>2</sub> absorbent canister is installed in place. If not, the alarm message of [CO<sub>2</sub> Canister Not Mounted] is displayed on the screen. In this case, push the
-

---

---

** WARNING**

Audio Pause key and a dialog box pops up prompting [Are you sure you want to disable the "CO<sub>2</sub> Canister Not Mounted" alarm for more than 2 minutes? ]. This alarm message changes to prompt message when [Ok] is selected.

- After replacing the CO<sub>2</sub> absorbent or mounting CO<sub>2</sub> absorber, ensure that CO<sub>2</sub> can be fully absorbed by the absorbent.

---

**NOTE**

- The CO<sub>2</sub> absorbent canister should only be used with air, oxygen, nitrous oxide, Halothane, Enflurane, Isoflurane and Sevoflurane.
- Change absorbent when necessary to prevent the build-up of non-metabolic gases when the system is not in use.
- When absorber is on, all gases will pass through the absorbent.
- Before installing the CO<sub>2</sub> absorbent canister, check that the seal between the breathing system and the CO<sub>2</sub> absorbent canister is in good condition. If not, replace the seal immediately.

---

## Assemble the CO<sub>2</sub> Absorbent Canister

1. The following figures show the components of a CO<sub>2</sub> absorbent canister:

- A. Absorbent
- B. Canister support
- C. Canister sponge
- D. CO<sub>2</sub> absorbent canister
- E. Canister handle
- F. Canister support buckle

Press the buckle as shown in the illustration to remove the canister support.

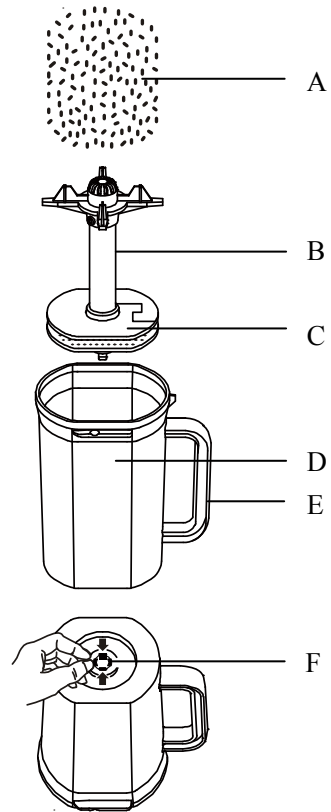

- 
2. Before installing the CO<sub>2</sub> absorbent canister, inspect the canister rim, canister support and seal for absorbent particles. If there is, please clean it.

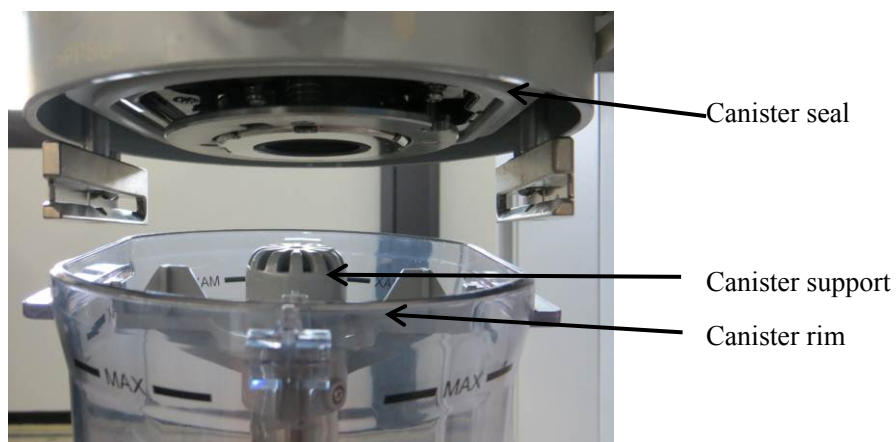

3. Align the CO<sub>2</sub> absorbent canister with the mounting slot.

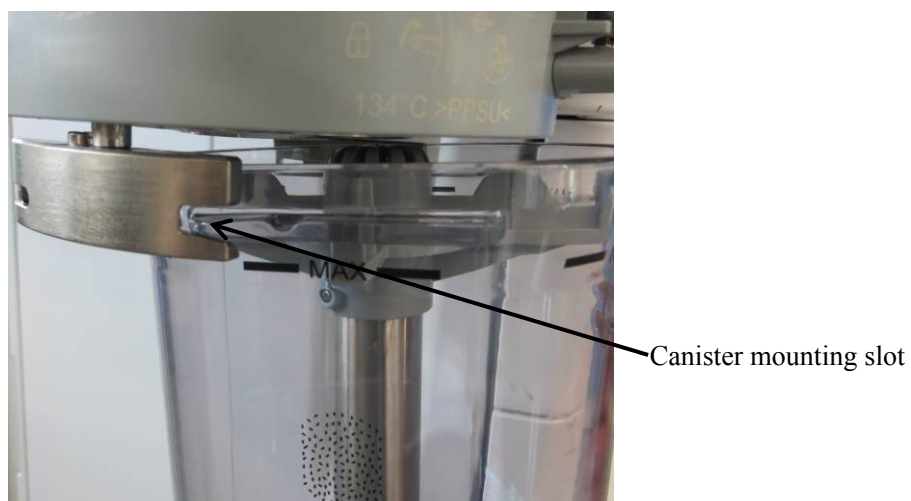

4. Push the CO<sub>2</sub> absorbent canister into the mounting slot.





- 
5. Turn the rotary handle clockwise for 90 degrees.



6. Let the rotary handle fall to lock the CO<sub>2</sub> absorbent canister.

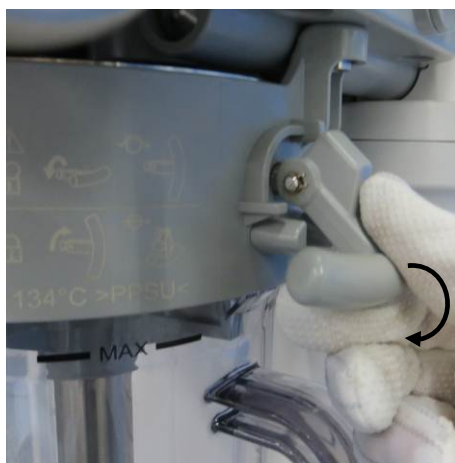

---

**⚠ CAUTION**

- Remember to do a breathing system leak test after reinstalling the CO<sub>2</sub> absorbent canister.

---

## Change the Absorbent

### NOTE

---

- A gradual color change of the absorbent in the canister indicates absorption of carbon dioxide. The color change of the absorbent is only a rough indicator. Use carbon dioxide monitoring to determine when to change the absorbent.
  - Follow local regulations regarding disposal of hospital waste when the absorbent has changed color. If left standing for several hours, it may regain its original color giving a misleading indication of activity.
  - Medisorb™ absorbent is recommended.
- 

1. Disassemble the CO<sub>2</sub> absorbent canister.
2. Pour out the absorbent which has changed color.
3. Press the canister support buckle to remove the canister support. Replace the CO<sub>2</sub> absorbent canister sponge.

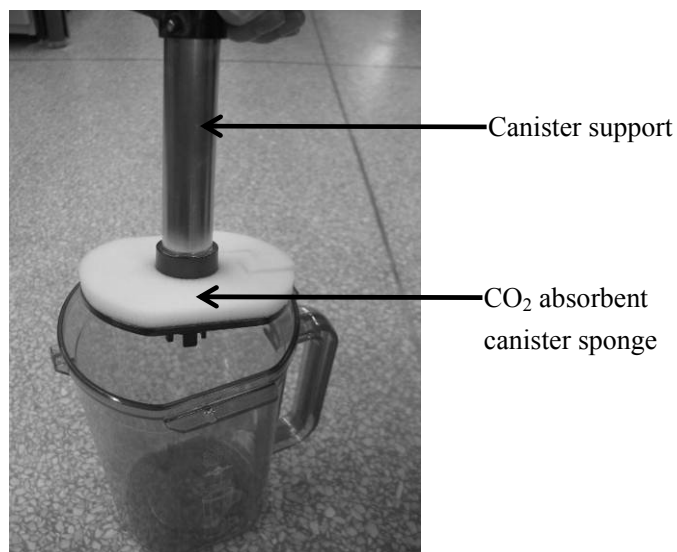

- 
4. Pour new absorbent into the CO<sub>2</sub> absorbent canister. When pouring, prevent the absorbent from falling on the venthole of the canister support, which may increase airway resistance.

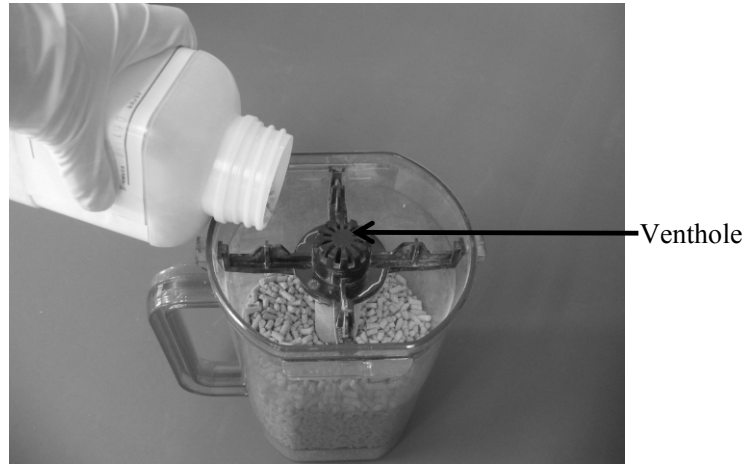

5. Install the canister support into the canister. Depress the canister support buckle to lock the canister.
6. Mount the CO<sub>2</sub> absorbent canister.



---

## **WARNING**

- Do not reuse the CO<sub>2</sub> absorbent canister sponge, which must be replaced every time the CO<sub>2</sub> absorbent canister is replaced.
  - The CO<sub>2</sub> absorbent canister sponge must be in place to prevent dust and particles from entering the breathing system.
  - When re-installing the CO<sub>2</sub> absorbent canister after changing the absorbent, ensure that the canister is locked firmly and installed in position.
-

---

## NOTE

- The absorbent poured in should not exceed the **MAX** level marked on the CO<sub>2</sub> absorbent canister.

---

### 11.1.2.9 Install the Breathing Tubes

## NOTE

- When installing the breathing tube, hold the tube connector at both ends of the tube to prevent damage of the tube.
- Do not reuse the filter to prevent cross-contamination.
- Install the filter as described in this manual to prevent dust and particles from entering the animal's lungs and prevent cross-contamination.

1. The following picture shows the filter to be mounted at the animal connection.

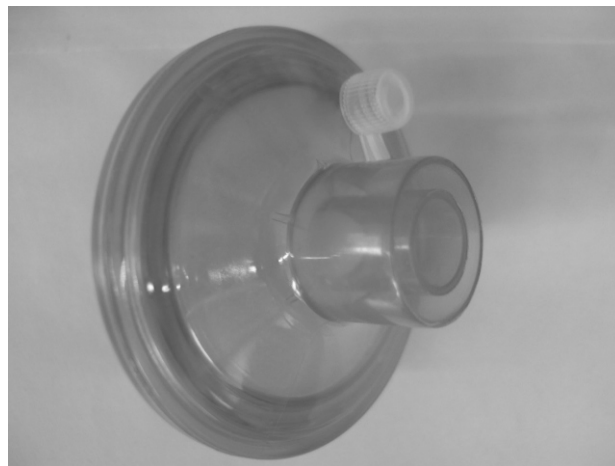

2. Connect the two ends of the breathing tubes to the inspiration/expiration connectors on the breathing system.

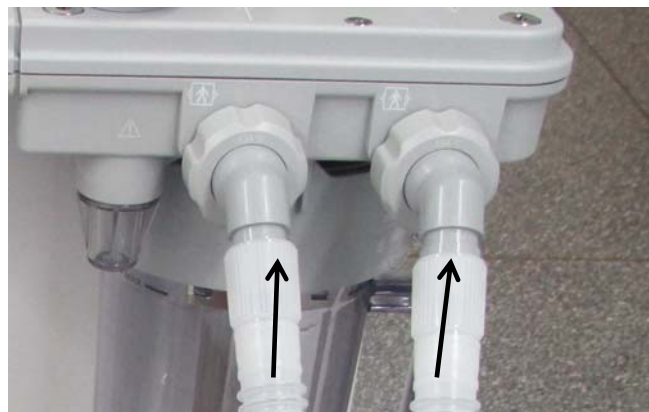

- 
3. Connect the filter to the Y-piece.



### 11.1.2.10 Install the Manual Bag

Connect the manual bag to the manual bag port on the breathing system.



---

## 11.2 Install the Vaporizer

---

### WARNING

---

- Use vaporizers compliant to ISO 80601-2-13. Refer to the vaporizer manufacturer's Instructions For Use for mounting, filling, or draining the vaporizer and other information.
  - If the vaporizer is incompatible with the anesthesia machine, the performance of the anesthetic agent in the vaporizer will be degraded. Use the vaporizer matching the anesthesia machine.
  - For this anesthesia machine, using or turning on more than one vaporizers simultaneously is prohibited.
- 

The barometric pressure may differ from the calibration pressure of the anesthetic vaporizer. This may cause an inaccurate output of the anesthetic agent. The operator should continuously monitor the concentration of anesthetic agent during system use to determine if the output concentration is accurate.

### 11.2.1 Assemble the Vaporizer

#### 11.2.1.1 Selectatec Mounting Mode

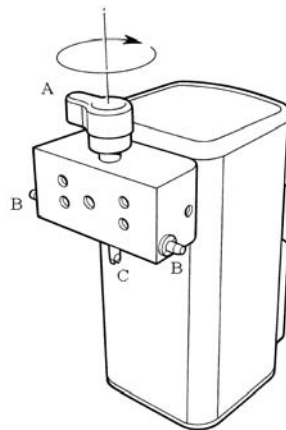

- A. Locking lever
- B. Interlock bolts
- C. Locking shaft

- 
1. Mount the vaporizer onto the manifold.



2. Push down and turn the locking lever (A) clockwise to lock the vaporizer in position.



3. Ensure that the top of the vaporizer is horizontal. If not, remove the vaporizer and reinstall it.
4. In case of reinstalling the vaporizer, try to lift each vaporizer straight up off the manifold rather than tilting. Do not rotate the vaporizer on the manifold.
5. If a vaporizer lifts off the manifold, install it again and complete steps 1 through 3. If the vaporizer lifts off a second time, do not use the system.

- 
6. Try to turn on more than one vaporizer at the same time.
  7. Test each possible combination. If more than one vaporizer turns on at the same time, remove the vaporizers, install them again, and complete steps 1 through 7.

### 11.2.1.2 Plug-in Mounting Mode

1. Mount the vaporizer onto the manifold.



2. Rotate the self-locking device clockwise to fix the vaporizer onto the manifold.



3. Ensure that the top of the vaporizer is horizontal. If not, remove the vaporizer and reinstall it.
4. In case of reinstalling the vaporizer, try to lift each vaporizer straight up off the manifold rather than tilting. Do not rotate the vaporizer on the manifold.
5. If a vaporizer lifts off the manifold, install it again and complete steps 1 through 3. If the vaporizer lifts off a second time, do not use the system.



- 
6. Press “0” button and rotate the control dial counterclockwise to make the vaporizer AG concentration output indicate “0” position. Then the vaporizer is ready for use.

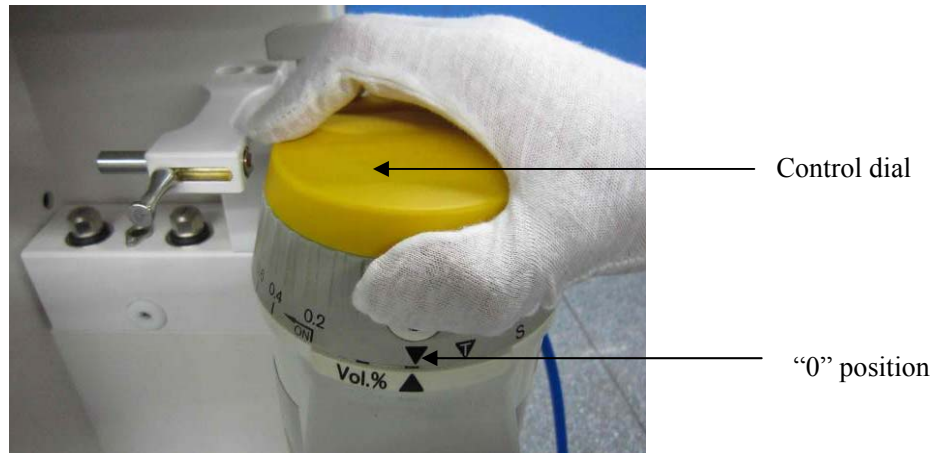

7. For the vaporizer to be locked, push the interlocking device into the hole on the vaporizer cover so that the vaporizer is locked.



## 11.2.2 Fill the Vaporizer

---

### **WARNING**

- **Ensure that the correct anesthetic agent is used. The vaporizer is designed with the specific anesthetic agent named on it and further indicated by color coded labeling. The concentration of the anesthetic agent actually output will vary if the vaporizer is filled with the wrong agent.**
-

---

### 11.2.2.1 Pour Fill System

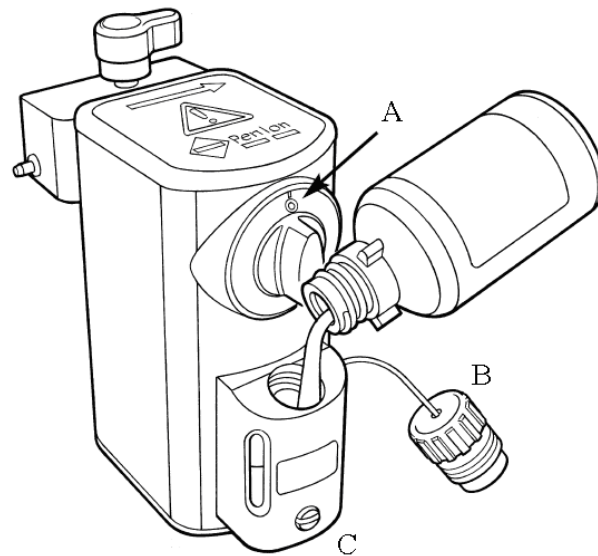

1. Check that the vaporizer concentration control (A) is in the 0 (zero) position. Check that the drain screw (C) is fully tightened.
2. Unscrew the filler cap (B).
3. Allow the liquid to flow into the vaporizer slowly. Pay attention to the liquid level during filling. Stop filling when the maximum level mark is reached.
4. Tighten filler cap (B) properly.

---

### 11.2.2.2 Quik-Fil System

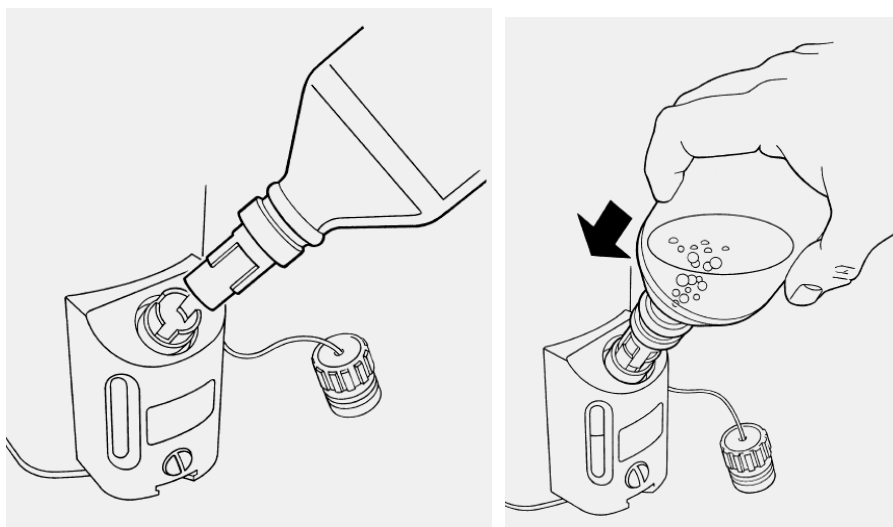

1. Check that the vaporizer concentration control is in the off (“0”) position.
2. Remove the protective cap from the anesthetic agent bottle filler, checking that the bottle and filler mechanism are not damaged.
3. Remove the vaporizer filler block cap and insert the bottle nozzle into the filler block. Rotate the bottle to align the bottle filler keys with the slots in the filler block.
4. Note the liquid level in the vaporizer window and press the agent bottle firmly into the vaporizer filler against the spring valve assembly. Allow the liquid to flow into the vaporizer until the maximum level mark is reached, paying continuous attention to the level in the window and the air return bubbles flowing into the bottle.
5. Release the bottle when the vaporizer is full and the continuous stream of bubbles ceases.
6. Pull out the bottle from the vaporizer filler and replace the vaporizer filler block cap, and the protective cap on the agent bottle

#### NOTE

- 
- The vaporizer volume is 300 mL at the maximum liquid level and 40 mL at the minimum liquid level.
-

---

### 11.2.2.3 Keyed Filler System

1. Check that the vaporizer concentration control (A) is in the off (“0”) position.
2. Attach the Keyed Filler adaptor (B) to the bottle (C).
3. Tighten the adaptor to ensure an airtight joint, which must be maintained throughout the filling operation.

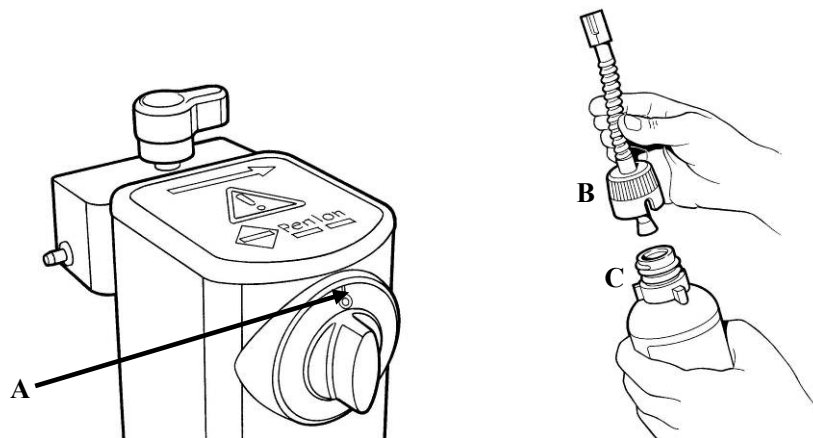

4. Loosen the clamp screw (D). Remove the plug (E).
5. Insert the keyed end of the bottle adaptor B fully into the vaporizer receiver. Tighten the clamp screw (D) to secure the adaptor.
6. Raise the bottle above the filler.
7. Open the filler control (F) – lift upwards. Allow the liquid to flow into the vaporizer until the upper mark is reached on the filler block window (G).

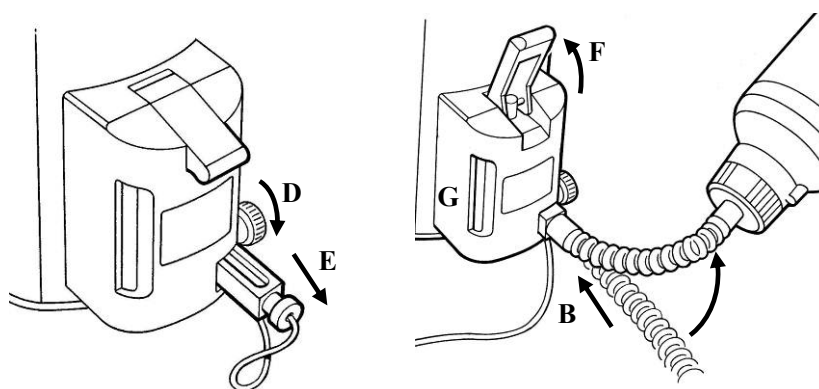

8. Close the filler control (F).
9. Lower the bottle below the level of the filler and allow the liquid in the bottle adaptor to flow back into the bottle. Loosen the clamp screw (D), remove the bottle adaptor from the receiver.

- 
10. Insert the plug (E) and tighten the clamp screw (D).

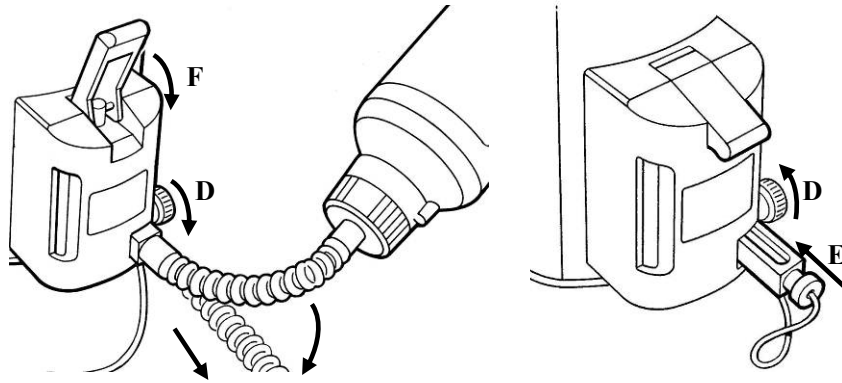

### 11.2.3 Drain the Vaporizer

---

#### WARNING

---

- Do not reuse the agent drained from the vaporizer. Treat as a hazardous chemical.
- 

#### 11.2.3.1 Pour Fill System

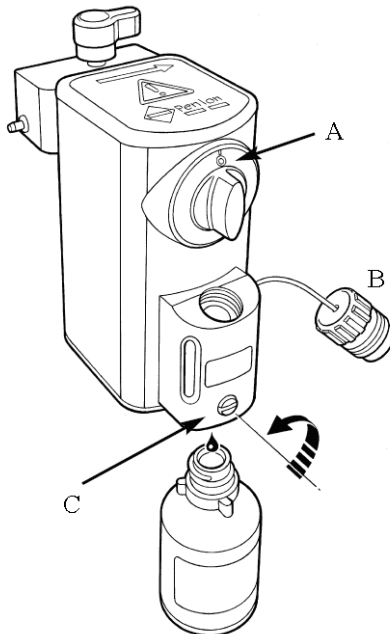

1. Check that the vaporizer concentration control (A) is in the 0 (zero) position.
2. Unscrew the filler cap (B).
3. Place a bottle marked with the drug name on the vaporizer under the drain tube in the base of the filler block. Turn the drain screw (C) anti-clockwise to allow the liquid to run into the bottle.

---

### 11.2.3.2 Quik-Fil System

#### NOTE

- 
- To avoid spillage, check that the bottle to be used for draining has sufficient capacity for the volume of liquid to be drained.
- 

---

#### WARNING

---

- The filler cap must be refitted before using the vaporizer.
- 

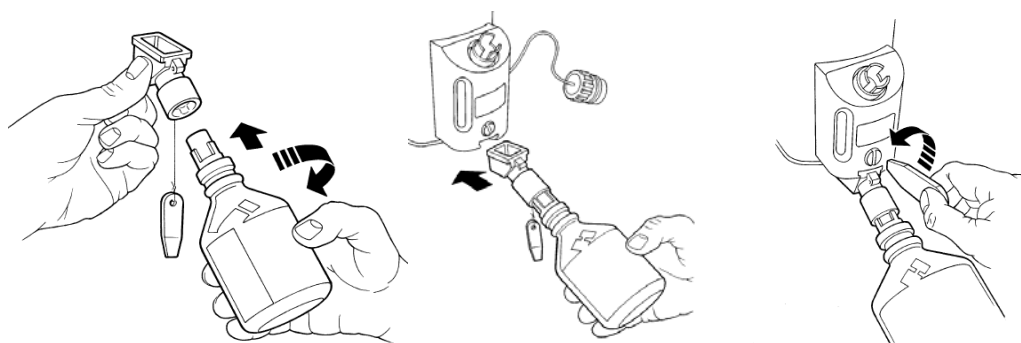

1. Remove the protective cap from an empty bottle. Insert the bottle nozzle into the drain funnel. Rotate the bottle to align the bottle filler keys with the index slots in the drain funnel, and screw the drain funnel onto the empty bottle.
2. Remove the vaporizer filler block cap.
3. Fully insert the drain funnel into the keyed drain slot, and unscrew the drain plug. Continue to drain the vaporizer until empty. Close the drain plug and tighten, and pull out the drain funnel.
4. Unscrew the drain funnel from the bottle and refit the bottle cap and the vaporizer filler block cap.

---

### 11.2.3.3 Keyed Filler System

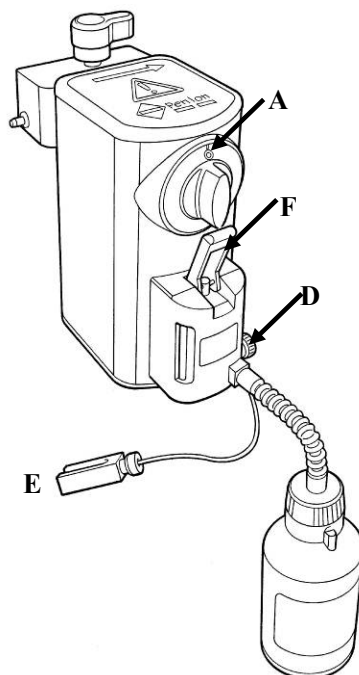

1. Check that the vaporizer concentration control (A) is in the off (“0”) position.
2. Attach the Keyed Filler adapter (B) to the bottle (C).
3. Tighten the adapter to ensure an airtight joint, which must be maintained throughout the filling operation.
4. Insert the keyed end of the bottle adapter (B) fully into the vaporizer receiver.
5. Tighten the clamp screw (D) to secure the adapter.
6. Keep the bottle below the filler.
7. Raise the filler control (F) and allow the liquid to run into the bottle until the flow ceases.
8. Close the filler control (F), loosen the clamp screw (D), and reinsert the plug (E). Tighten the clamp screw (D).

---

## 11.3 Replace the Gas Cylinder

To change a gas cylinder, do as follows:

1. Turn the handle of the cylinder valve clockwise. Close the cylinder valve on the cylinder to be replaced

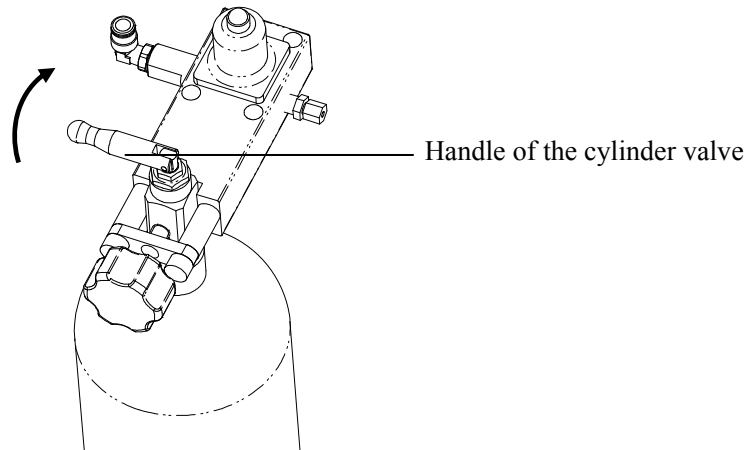

2. Turn the knob anticlockwise.

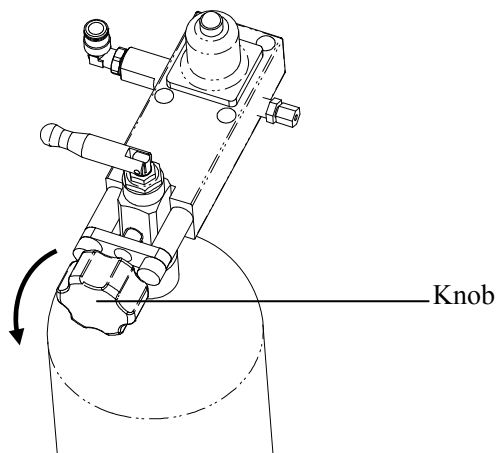

3. Fully loosen the knob to open the yoke gate.

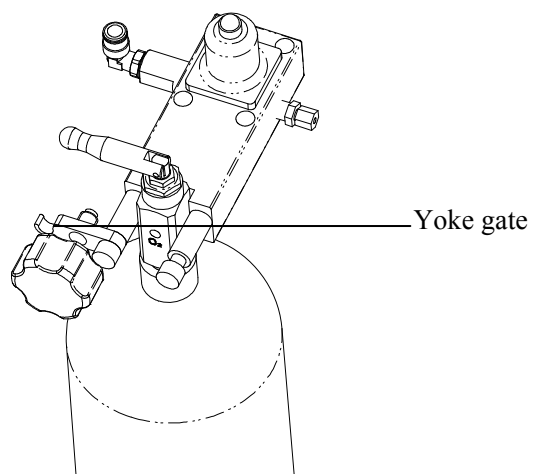



- 
4. Remove the used cylinder.

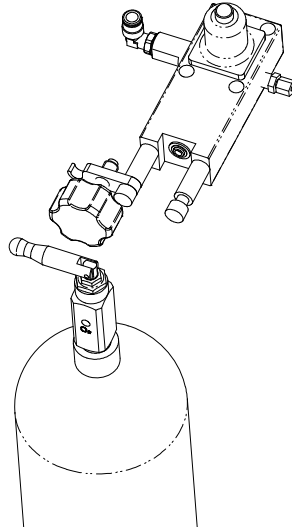

5. Replace with a new cylinder. Point the cylinder outlet away from all items that can be damaged by a release of high pressure gas.
6. Quickly open and close the cylinder valve. This removes dirt from the cylinder outlet.
7. Put the cylinder in the cylinder bracket.
8. Close the yoke gate and tighten the knob.
9. Do a high pressure leak test. For details, refer to **6.8 Cylinder Tests**.

---

**⚠ WARNING**

- **Do not leave gas cylinder valves open if the pipeline supply is in use. Cylinder supplies could be depleted, leaving an insufficient reserve supply in case of pipeline failure.**
-

---

## 11.4 Install the Modules

Push the module into the slot until you hear a click, indicating the module is installed in place. To remove the module, push the tab at the bottom of the module upwards, and then pull the module outward.

After inserting the module, ensure that the indicator on the module is lit up. If not, re-install the module.

### 11.4.1 Install the CO<sub>2</sub> Module



### 11.4.2 Install the AG Module



---

## 11.5 Pneumatic Connections

This anesthesia machine provides two types of connections —pipeline connections (for O<sub>2</sub>, N<sub>2</sub>O and Air) and cylinder connections (for O<sub>2</sub>, N<sub>2</sub>O and Air).

For details, refer to **2.2 Equipment Appearance**.

---

### **WARNING**

---

- **Use medical grade gas supplies only. Other types of gas supplies may contain water, oil, or other contaminants.**
  - **When the central piping system fails, one or more equipment connected may stop work. Ensure that cylinders are available.**
  - **When gas supplies are cut off, there is still pressure inside the pipeline. Remember to release the gas inside the pipeline before removing the tube.**
  - **If the [Drive Gas Pressure Low] alarm occurs when the gas supply pressure is greater than 200 kPa, contact your service personnel or Mindray.**
  - **The anesthesia machine stops gas delivery when the supply gas pressure is lower than 200 kPa.**
-

---

### 11.5.1 Connect the Pipeline Gas Supplies

The anesthesia machine provides three (O<sub>2</sub>, N<sub>2</sub>O and Air) pipeline supply connections which are connected to three hoses of different colors and cannot be exchanged. Connect the pipeline gas supplies as follows:

1. Check that the seal at the hose connector is in good condition before connecting the gas supply hose. If damaged, do not use the hose. Replace the seal to avoid leakage.
2. Align the hose connector with the matching gas supply inlet at the side of the anesthesia machine and then insert it.



3. Ensure that the hose is properly connected and tighten the tube nut.



### 11.5.2 Connect the Cylinder Gas Supply

For details, refer to *11.3 Replace the Gas Cylinder*

---

### 11.5.3 Connect the Backup Oxygen Supply

It is no need to do this operation if the system does not configure with backup oxygen supply.

This system can connect to the backup oxygen supply. The oxygen supply hose assembly is identified with the color of oxygen.

How to connect the oxygen supply hose assembly to the system is as follows:

1. Check if the sealing ring of the connector is intact before connecting the oxygen supply hose assembly to the system. If the sealing ring is damaged, this oxygen supply hose assembly cannot be used. Change the sealing ring, or it will cause leakage.
2. Plug the connector of the oxygen supply hose assembly to the backup oxygen supply inlet on the rear of the unit.
3. Ensure that the oxygen supply hose assembly is connected to the unit firmly. Screw the screw nut of the hose by hands.

### 11.6 Sample Gas Return Port and AGSS Outlet

The sample gas return port and AGSS outlet are Located on the right side of the rear of the machine, as shown below:



The outside diameter of the AGSS outlet is 30 mm. with 1:20 taper ratio. Please connect to the AGSS or waste gas disposal system.

---

#### **WARNING**

- **Before performing an operation on the animal, equip the anesthesia machine with anesthesia gas scavenging system which complies with ISO 80601-2-13 to purify the air in the operating room.**
  - **If your anesthesia machine is not configured with active AGSS, do not connect the AGSS outlet of the anesthesia machine to the active hospital's waste gas disposal system.**
-

---

## 11.7 AGSS Transfer and Receiving System

### 11.7.1 Components

1. Flow control
2. Top cover
3. Filter screen
4. Window
5. Guide slot locking knob
6. Fixing plate
7. Pressure compensation opening
8. Sleeve  
Connects to the AGSS active scavenging hose
9. Outlet
10. Float
11. Catheter tube
12. Main body
13. Inlet
14. Transfer tube connector 1  
Connects to the gas inlet.
15. Spring of the gas-in hose
16. Transfer tube
17. Transfer tube connector 2  
Connects to the AGSS outlet of the anesthesia machine.

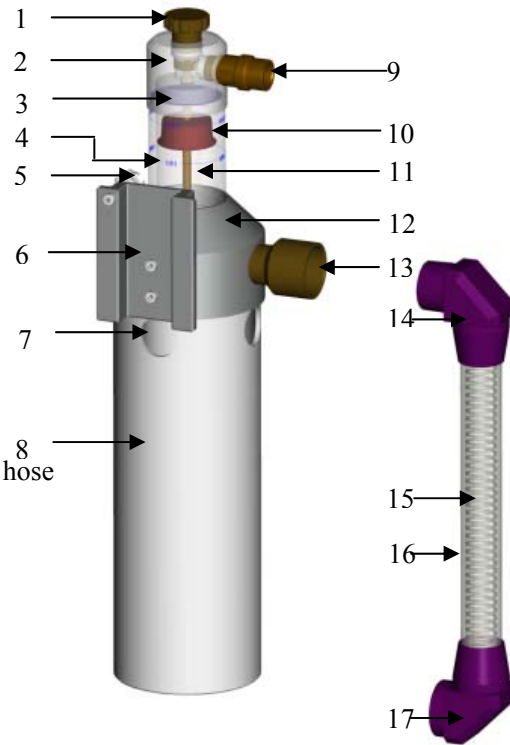

---

## 11.7.2 Assemble the AGSS

1. Mount the AGSS bracket onto the lower left decorative plate of the anesthesia machine.

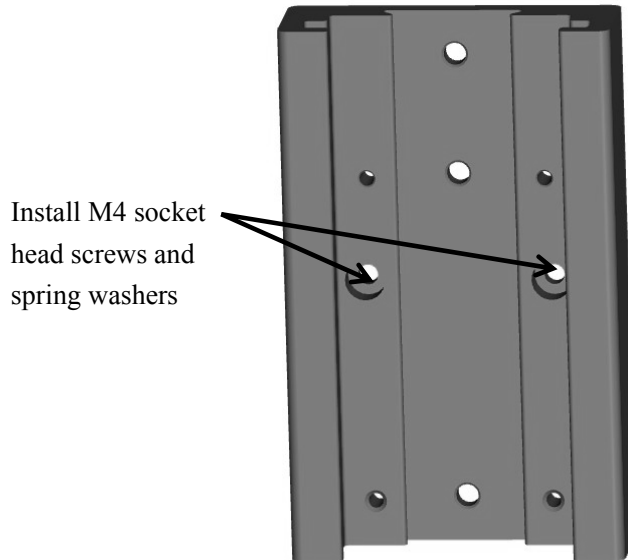

2. Mount the AGSS system already equipped with hook onto the AGSS bracket. Connect the AGSS inlet to the AGSS outlet of the anesthesia machine through the transfer tube. Connect the AGSS outlet to the hospital's waste gas disposal system using the AGSS active scavenging hose.

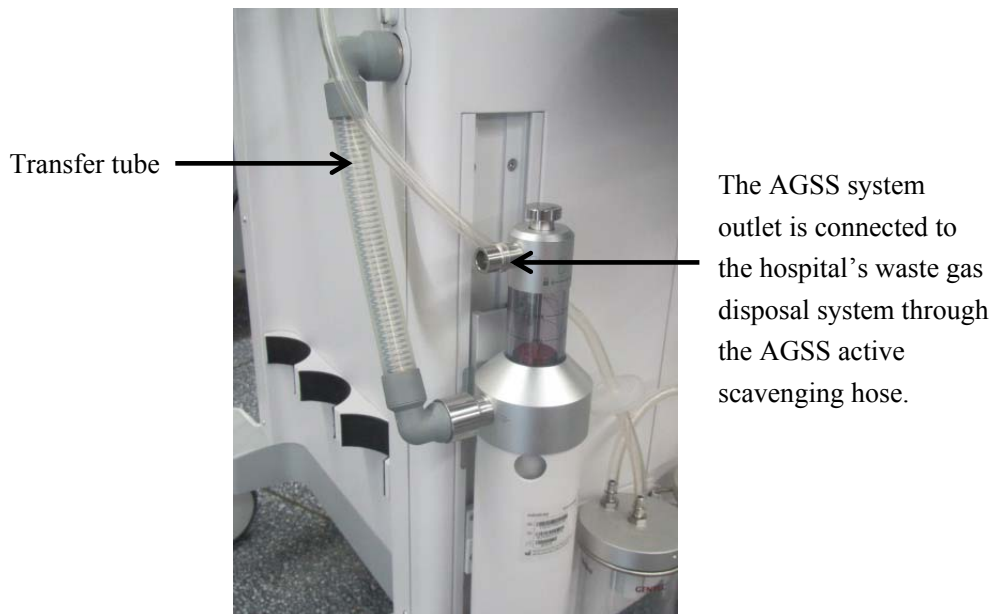

---

When the ACGO circuit needs to discharge the gas to the AGSS, you can use the adapter as below.

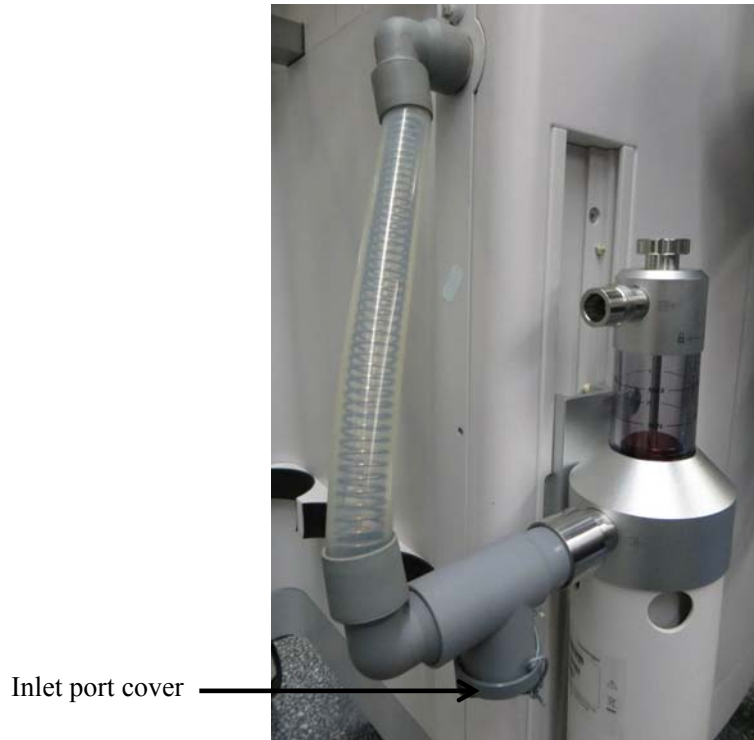

## NOTE

- 
- Remove the AGSS transfer and receiving system from the main unit when transporting or moving the anesthesia machine.
  - Keep the inlet port cover closed when the ACGO circuit is not used.
-



---

### 11.7.3 Waste Gas Disposal System

The AGSS transfer and receiving system is of high/low flow type, which is in compliance with ISO 80601-2-13. The applicable pump rate ranges from 25 to 50 L/min or from 75 to 105 L/min.

Before use, ensure that the waste gas disposal system is the same flow rate disposal system and is able to reach the flow range.

Before use, ensure that the connector of the waste gas disposal system is ISO 9170-2 standard connector.

For details about specifications, refer to *B.II AGSS Transfer and Receiving System Specifications*.

#### NOTE

- 
- Do not block the pressure compensation opening of the AGSS transfer and receiving system when in use.
  - The leakage of the TRANSFER and RECEIVING SYSTEM is measured using method recommend in Annex E of ISO 8835-3.
- 

---

#### WARNING

---

- This AGSS transfer and receiving system cannot be used with flammable anesthetic agent.
  - If the hose between the waste gas disposal system and the AGSS is occluded, or the extract flow of the waste gas flow system is insufficient, or the waste gas disposal system malfunctions, the waste gas inside the AGSS may overflow into the atmosphere at the rate more than 100 mL/min. In this case, it is recommended not to use the AGSS.
-

---

## 11.8 Negative Pressure Suction Device

### 11.8.1 Structure and Components

The negative pressure suction device is mainly composed of negative pressure regulator, liquid collection bottle, suction tube, and filter. It is used for collecting medical waste liquid and provides overfill protection to prevent fully collected waste liquid from flowing backward so as to ensure the tubing safety.



- Negative pressure suction switch (Ignore it if the negative pressure suction device is not configured with this switch.): can be set to ON or OFF. The negative pressure suction device is connected to the gas source when it is set to ON and is disconnected from the gas source when set to OFF.
- Swapping switch: swaps between the working modes of the negative pressure suction device. It can be set to FULL, OFF, or REG. FULL indicates that the negative pressure suction device is working with the maximum pressure and the knob does not function. OFF indicates that the negative pressure suction device is not working. REG indicates that the negative pressure suction device is working with its pressure adjusted through the knob.
- Pressure gauge: displays the current working pressure of the negative pressure suction device.
- Knob: adjusts the working pressure of the negative pressure suction device.
- Overfill protection: prevents the fully collected waste liquid from flowing backward so as to ensure the tubing safety.

---

## 11.8.2 Install the Negative Pressure Suction Device

1. Lock the screws with wrench. Fix the rack for the liquid collection bottle onto the anesthesia machine.



2. Place the liquid collection bottles into the rack. Install the suction tube based on the silkscreen on the liquid collection bottle.

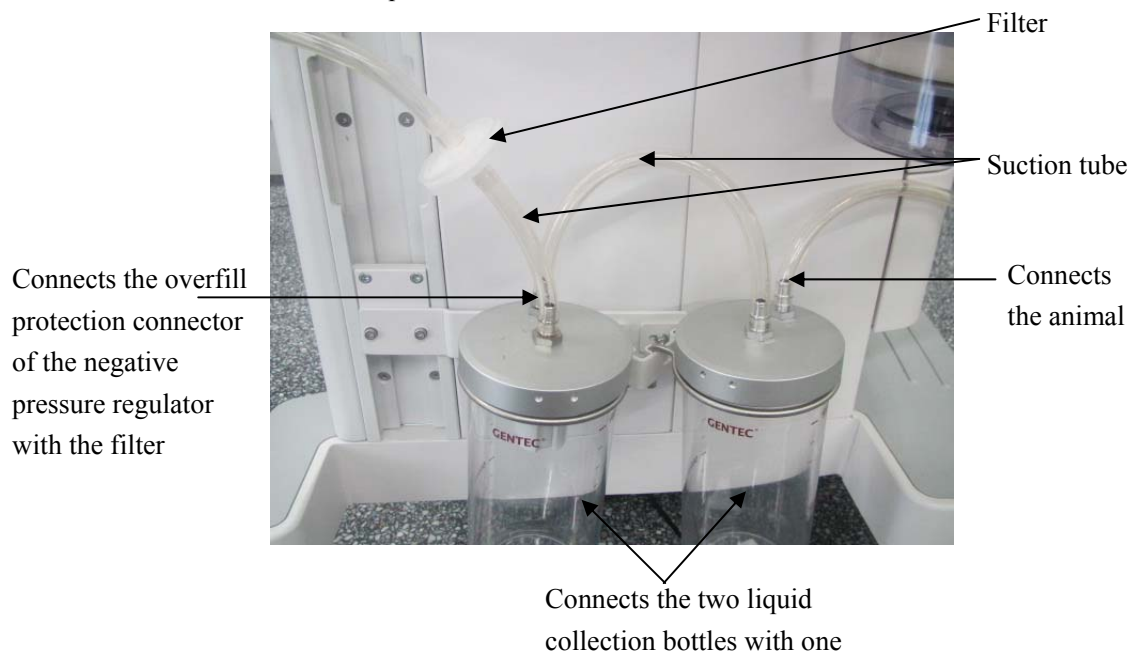

- 
3. Align with the handle of the anesthesia machine to slide the negative pressure regulator onto the handle. Tighten the nut to fix the negative pressure regulator.

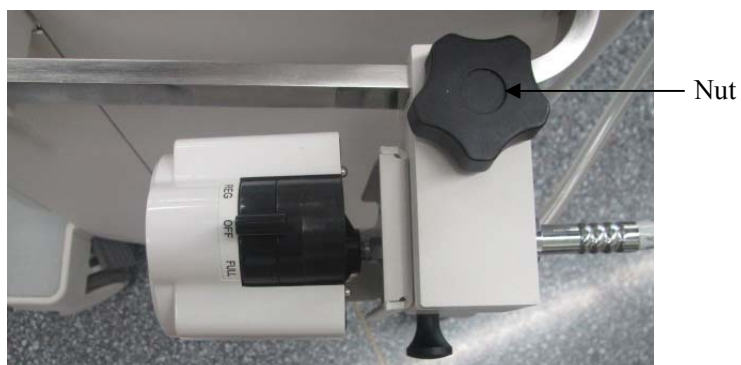

4. Insert the suction tube into the overfill protection connector. Then lift the nut and adjust the direction of the suction opening at the same time. Lower the nut after adjusting direction properly.



- 
5. Align the other end of the gas supply tube on the negative pressure regulator with the drive gas tee connector on the anesthesia machine and tighten the nut.

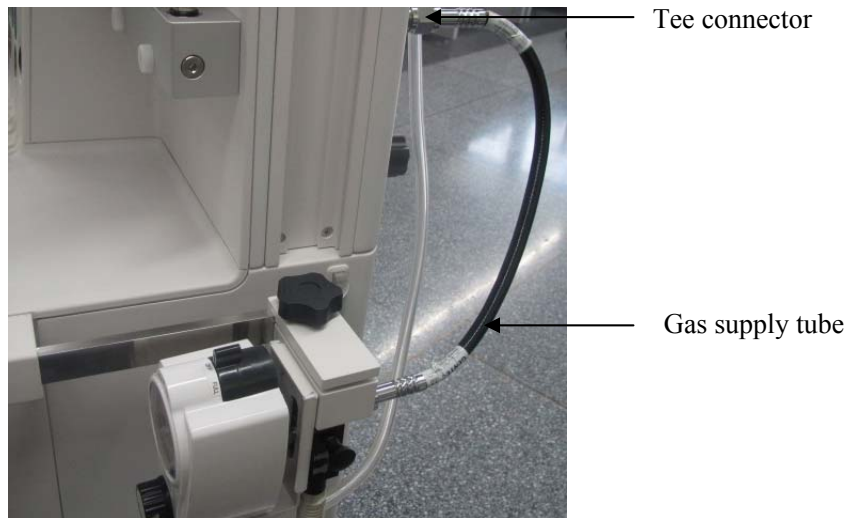

Or

Align the other end of the gas supply tube on the negative pressure regulator with the hospital's wall.

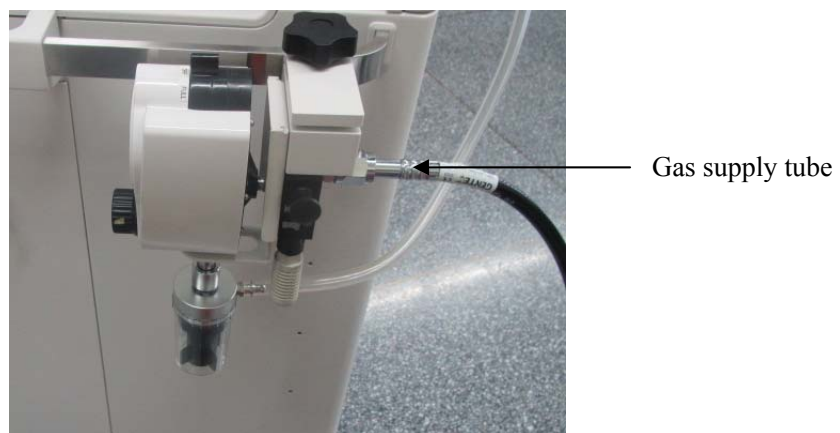

### 11.8.3 Turn on/off the Negative Pressure Suction Device

To turn on the negative pressure suction device:

1. Set the negative pressure suction switch to ON (Ignore this operation if the negative pressure suction device is not configured with this switch.).
2. Set the swapping switch to REG.
3. Adjust the knob to cause the reading on the pressure gauge to be greater than -40 kPa.

---

To turn off the negative pressure suction device:

1. Set the swapping switch to OFF.
2. Set the negative pressure suction switch to OFF (Ignore this operation if the negative pressure suction device is not configured with this switch.).

---

 **WARNING**

---

- **Keep the negative pressure suction switch in OFF status when not in use to prevent the hazard of high O<sub>2</sub> concentration in OR.**
-

# 12 Cleaning and Disinfection

---

---

## **WARNING**

---

- Obey applicable safety precautions.
  - Read the material safety data sheet for each cleaning agent.
  - Read the operation and service manual for all disinfection equipment.
  - Wear gloves and safety glasses. A damaged O<sub>2</sub> sensor can leak and cause burns (contains potassium hydroxide).
  - Reuse of undisinfected breathing system or reusable accessories may cause cross-contamination.
  - The operations described in 6 Preoperative Test must be performed before animal use every time the anesthesia machine has been disassembled for cleaning and disinfection, or has been reassembled.
  - To prevent leaks, avoid damaging any component in case of disassembling and reassembling the breathing system. Ensure the correct installation of the system, especially of the seal. Make sure of the applicability and correctness of the cleaning and disinfection methods.
  - Disassemble and reassemble the breathing system as described in this manual. If you need to further disassembly and reassembly, contact us. Improper disassembling and reassembling may cause breathing system leak and compromise normal system use.
- 
- 

## **NOTE**

---

- Clean and disinfect the equipment as required before it is put into use for the first time.
  - To help prevent damage, refer to the manufacturer's data if you have questions about a cleaning agent.
  - Do not use organic, halogenated, or petroleum based solvents, anesthetic agents, glass cleaners, acetone, or other harsh cleaning agents.
  - Do not use abrasive cleaning agents (such as steel wool, silver polish or cleaner).
  - Keep all liquids away from electronic parts.
  - Do not permit liquid to go into the equipment housings.
  - Do not soak synthetic rubber parts for more than 15 min. Swelling or faster aging can occur.
- 
-

---

## NOTE

---

- **Only autoclave parts marked 134° C.**
  - **Cleaning solutions must have a pH of 7.0 to 10.5.**
  - **Before disinfection, the product should be fully disassembled.**
- 

## 12.1 Clean and Disinfect the Anesthesia Machine

### Housing

1. Clean the surface of the anesthesia machine housing (and accessories) with a damp cloth soaked in alkalescent detergent (clean water or soap water with pH of 7.0 to 10.5). Disinfect the surface of the anesthesia machine housing with a damp cloth soaked in medium- or high-efficiency detergent (such as 75% alcohol, 70% isopropanol, or 2% glutaraldehyde) solution.
  2. After cleaning or disinfecting the housing, remove the remaining detergent by wiping with a dry lint free cloth.
- 

### WARNING

---

- **Seeping liquid into the control assembly can damage the equipment or cause personal injury. When cleaning or disinfecting the housing, ensure that no liquid enters the control assemblies and always disconnect the equipment from the AC mains. Reconnect the AC mains only after the cleaned or disinfected parts are fully dry.**
- 

### NOTE

---

- **Use only soft dry and lint free cloth to clean the display. Do not use any liquid for display cleaning.**
-



---

## 12.2 Disassemble the Breathing System Cleanable

### Parts

You need to disassemble the breathing system cleanable parts first before cleaning the system.

#### 12.2.1 Breathing System Compatible with Pre-Pak

##### 12.2.1.1 O<sub>2</sub> Sensor

1. Remove the O<sub>2</sub> sensor cable from the O<sub>2</sub> sensor connector on the circuit adapter.



2. Remove the O<sub>2</sub> sensor from the O<sub>2</sub> sensor port on the breathing system.



---

### 12.2.1.2 Manual Bag

Remove the manual bag from the manual bag port on the breathing system as shown below.



### 12.2.1.3 Breathing Tubes

#### NOTE

- 
- When disassembling the breathing tube, hold the tube connectors at both ends of the tube to prevent damage to the tube.
  - Do not reuse the filter. Follow local regulations regarding disposal of hospital waste when the filter is discarded.
- 

1. Remove the filter from the Y-piece.



- 
2. Disconnect the breathing tubes from the inspiration/expiration connectors on the breathing system.



#### 12.2.1.4 Airway Pressure Gauge

Pull off the airway pressure gauge as shown below.



---

### 12.2.1.5 Bag Arm

1. Loosen the locking nut counterclockwise.



2. Remove the bag arm from the breathing system.



---

### 12.2.1.6 Bellows Assembly

1. Turn the bellows housing counterclockwise.



2. Lift off and remove the housing.

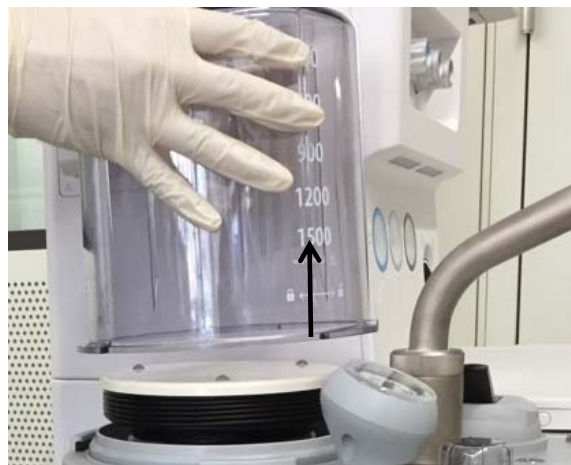

3. Remove the bellows assembly from the bellows base.

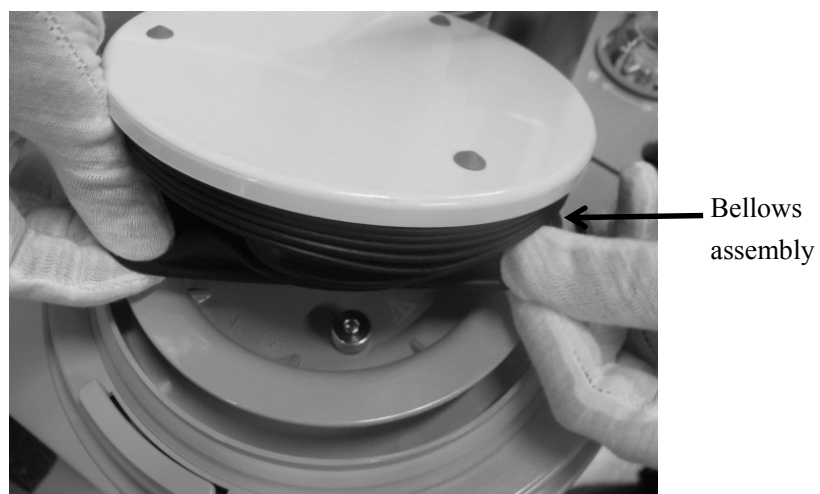

- 
4. Remove the bellows top plate from the bellows assembly.

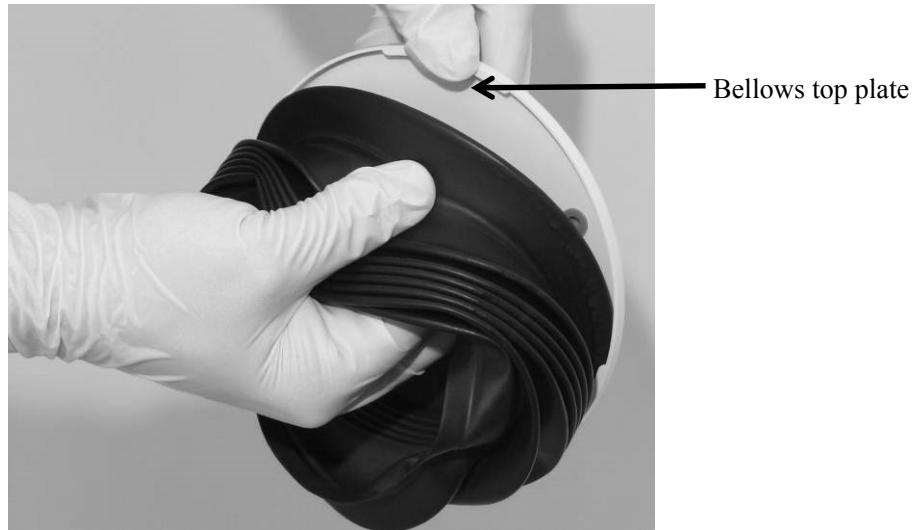

5. Remove the ring for bellows top plate.

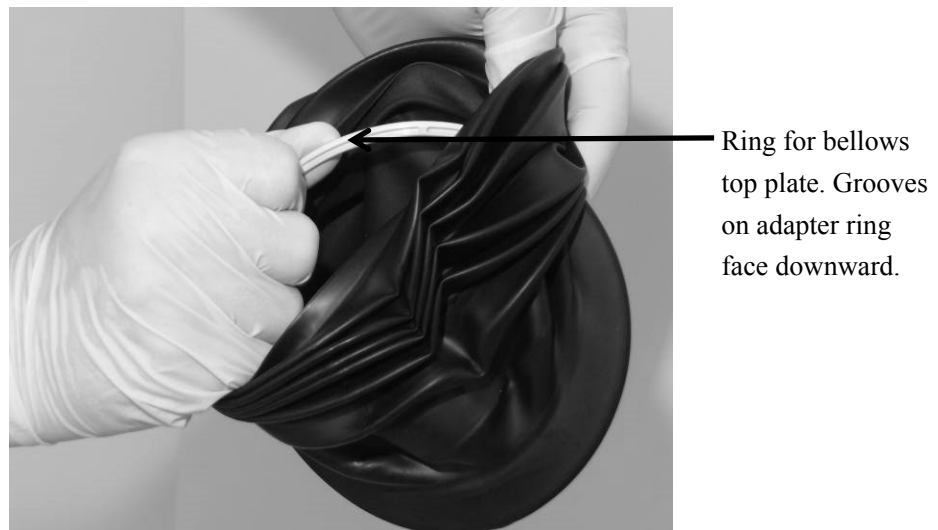

## NOTE

- 
- Note the orientation of the bellows adapter ring as it is being removed, to ensure that it is properly inserted during reassembly. If the ring contains grooves, the ring should be oriented so that the grooves are facing downward in the final reassembly.
-

- 
6. Remove the sealing ring.

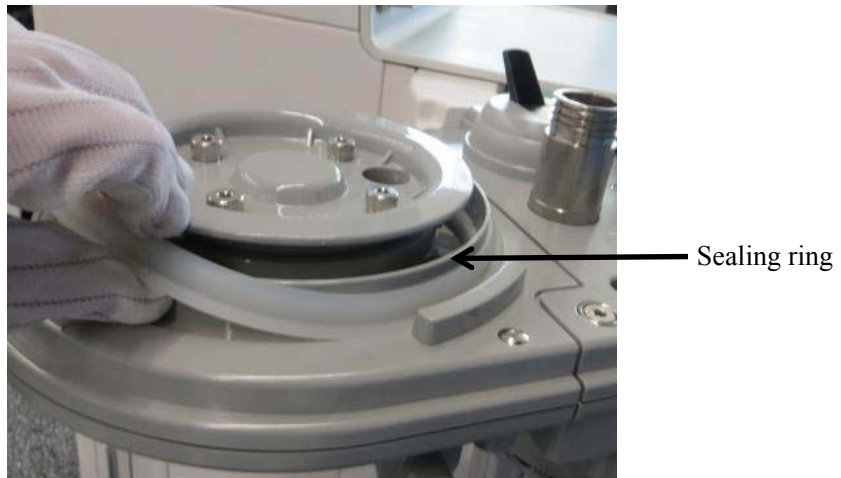

### 12.2.1.7 Flow Sensor

1. Turn the locking nuts counterclockwise.



2. Pull out the inspiration/expiration connectors and their locking nuts.



- 
3. Pull out the flow sensors horizontally.



### 12.2.1.8 Expiratory Check Valve Assembly

1. Turn the check valve cover counterclockwise to remove it.





- 
2. Pull out the check valve.



### 12.2.1.9 Inspiratory Check Valve Assembly

For details about how to disassemble the inspiratory check valve assembly, refer to 12.2.1.8 Expiratory Check Valve Assembly.

### 12.2.1.10 CO<sub>2</sub> Absorbent Canister

1. Place a water collection cup under the drainage valve. Turn the drainage valve knob anticlockwise. Open the drainage valve and collect the drained water with water collection cup. Then tighten the valve knob clockwise and close the drainage valve.



Drainage valve knob

- 
2. Rotate the handle to the position as shown below.



3. Take out the absorbent canister.
4. Press and hold the buckle on the Bypass assembly to take out the Bypass assembly downward.

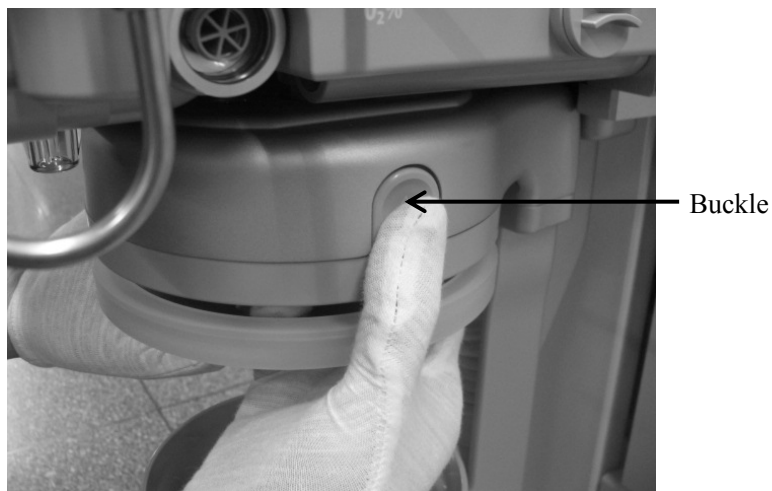

5. Pull out the CO<sub>2</sub> base assembly upward.

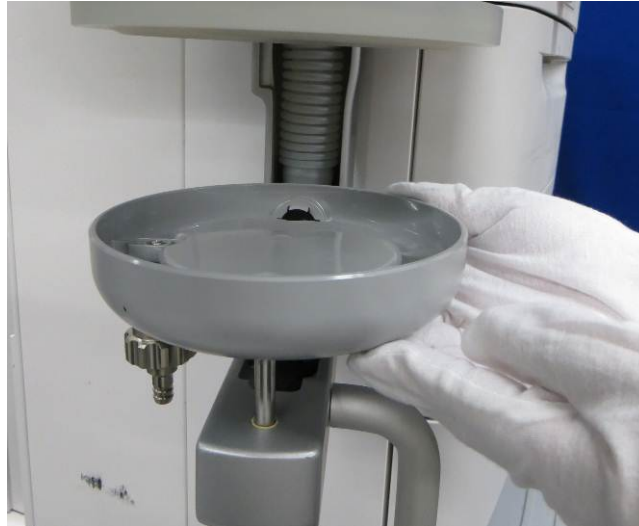

---

**⚠ WARNING**

---

- **Absorbent is a caustic substance and is a strong irritant to eyes, skin and respiratory system. Affected parts should be flushed with water. If irritation continues after flushed by water, seek medical assistance immediately.**
- 

#### **12.2.1.11 Water Collection Cup**

1. Hold the water collection cup and turn it anticlockwise.



2. Remove the water collection cup.

#### **12.2.1.12 Sample Gas Return Port**

If your breathing system is configured with sample gas return port and this function is in use, depress the metal clip to release exhaust tube connector. Then pull out the connector. For details, refer to *8.3.5 Scavenge the Sample Gas* or *8.4.4 Scavenge the Sample Gas* or *9.8 Scavenge the Sample Gas*.

---

### 12.2.1.13 Breathing system

Ensure that the above-mentioned assemblies are disassembled. Then remove the breathing system from the circuit adapter with both hands.

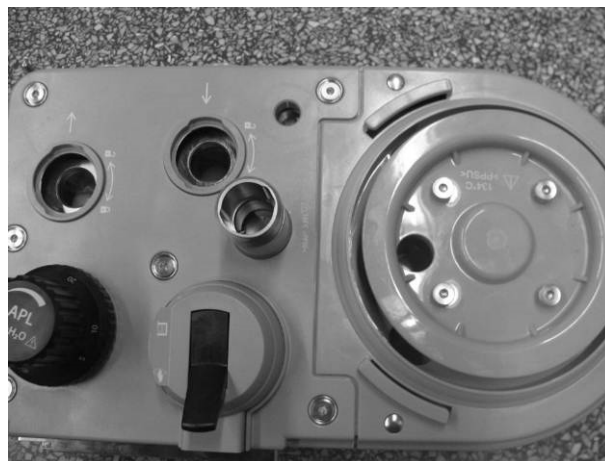

### NOTE

- If it is hard to push the breathing system into or out of the circuit adapter, you need to apply some lubricant (M6F-020003---: “DuPont Krytox high-performance fluorine lubricating grease”) to the seal on the pneumatic connector to reduce friction.
  - The breathing system cannot be removed before the CO<sub>2</sub> absorbent canister is removed.
-

---

## 12.2.2 Breathing System Not Compatible with Pre-Pak

### 12.2.2.1 O<sub>2</sub> Sensor

1. Remove the O<sub>2</sub> sensor cable from the O<sub>2</sub> sensor connector on the circuit adapter.



2. Remove the O<sub>2</sub> sensor cable from the O<sub>2</sub> sensor.



3. Unscrew the O<sub>2</sub> sensor from the O<sub>2</sub> sensor port on the breathing system.



---

### 12.2.2.2 Manual Bag

Remove the manual bag from the manual bag port on the breathing system as shown below.



### 12.2.2.3 Breathing Tubes

#### NOTE

- 
- When disassembling the breathing tube, hold the tube connectors at both ends of the tube to prevent damage to the tube.
  - Do not reuse the filter. Follow local regulations regarding disposal of hospital waste when the filter is discarded.
- 

1. Remove the filter from the Y-piece.



- 
2. Disconnect the breathing tubes from the inspiration/expiration connectors on the breathing system.

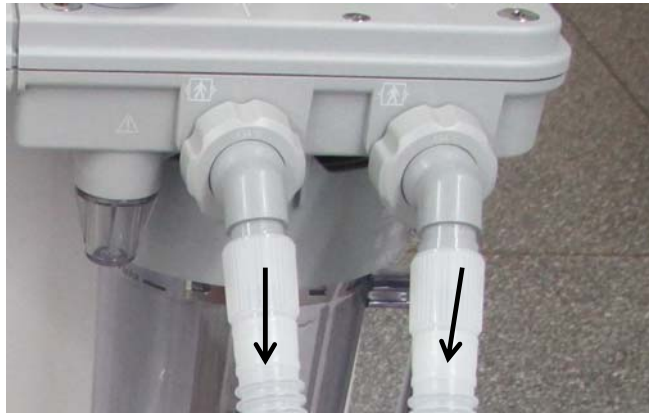

#### 12.2.2.4 Airway Pressure Gauge

Pull off the airway pressure gauge as shown below.



#### 12.2.2.5 Bag Arm

1. Loosen the locking nut counterclockwise.





- 
2. Remove the bag arm from the breathing system.



### 12.2.2.6 Bellows Assembly

1. Turn the bellows housing counterclockwise.



2. Lift off and remove the housing.

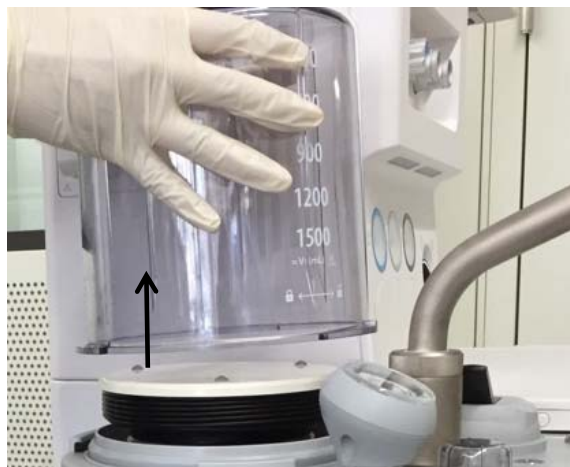



- 
3. Remove the bellows assembly from the bellows base.



4. Remove the bellows top plate from the bellows assembly.

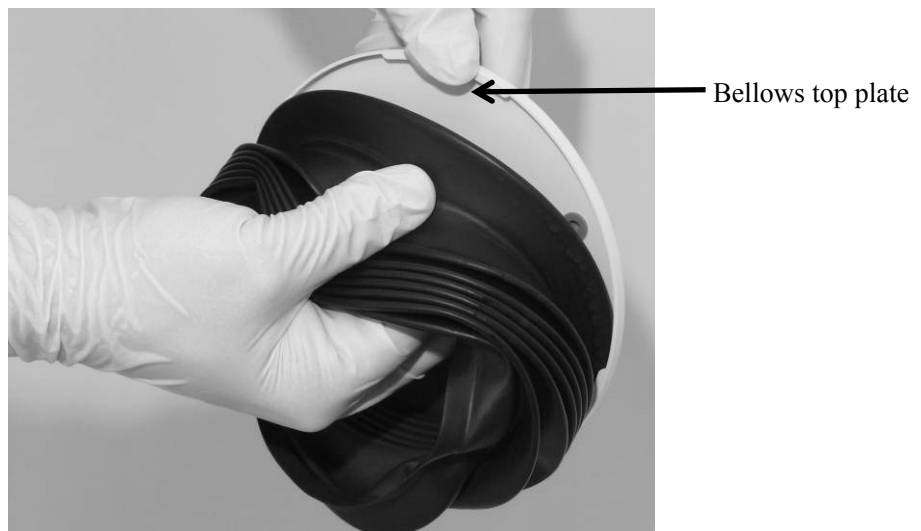

5. Remove the ring for bellows top plate.

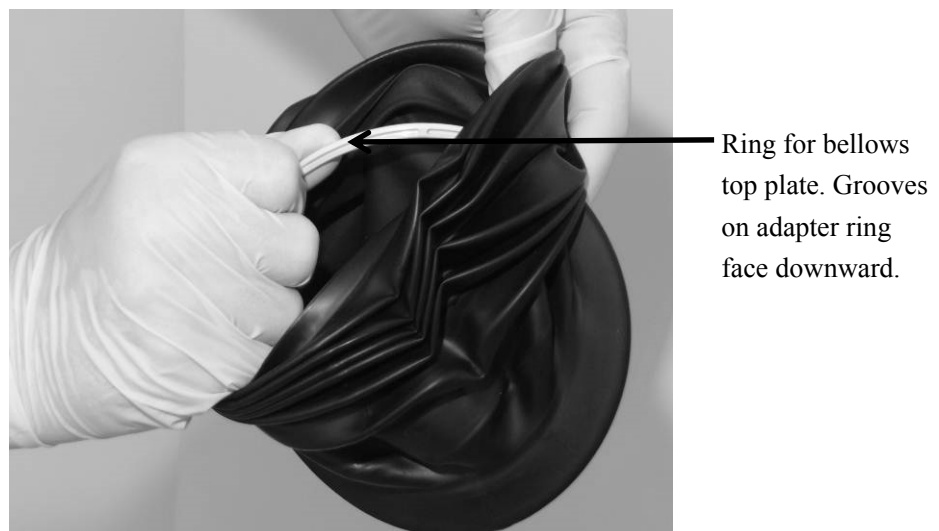

---

## NOTE

---

- Note the orientation of the bellows adapter ring as it is being removed, to ensure that it is properly inserted during reassembly. If the ring contains grooves, the ring should be oriented so that the grooves are facing downward in the final reassembly.
- 

6. Remove the sealing ring.

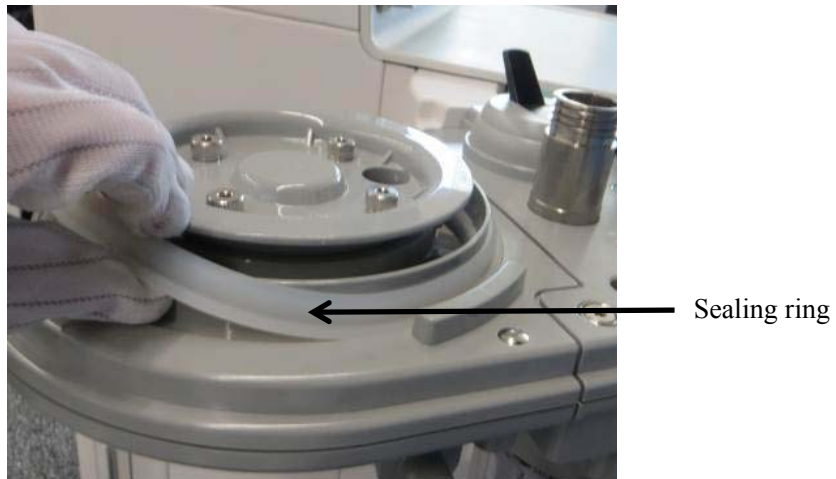

### 12.2.2.7 Flow Sensor

1. Turn the locking nuts counterclockwise.



- 
2. Pull out the inspiration/expiration connectors and their locking nuts.



3. Pull out the flow sensors horizontally.



### 12.2.2.8 Expiratory Check Valve Assembly

1. Turn the check valve cover counterclockwise to remove it.



- 
2. Pull out the check valve.



### 12.2.2.9 Inspiratory Check Valve Assembly

For details about how to disassemble the inspiratory check valve assembly, refer to [12.2.2.8 Expiratory Check Valve Assembly](#).

### 12.2.2.10 CO<sub>2</sub> Absorbent Canister

1. Pull up the rotary handle 90 degrees.



- 
- Turn the rotary handle for 90 degrees counterclockwise.



- Pull out the CO<sub>2</sub> absorbent canister from the mounting slot.

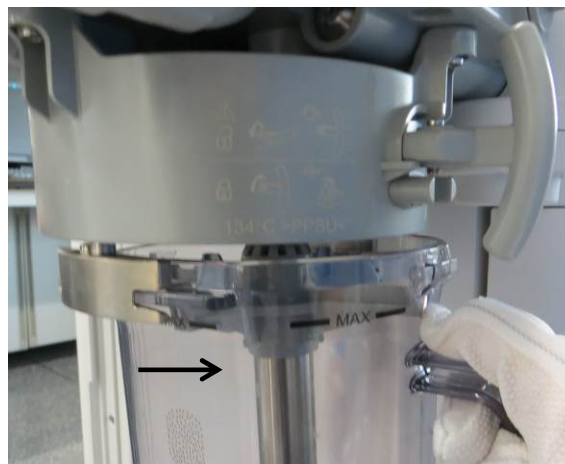

- To reassemble the canister, refer to *11.1.2.8 Install the Soda-lime container or CO<sub>2</sub> Absorbent Canister*.

---

---

**⚠ WARNING**

---

- Absorbent is a caustic substance and is a strong irritant to eyes, skin and respiratory system. Affected parts should be flushed with water. If irritation continues after flushed by water, seek medical assistance immediately.
- 
- 

### 12.2.2.11 Water Collection Cup

1. Hold the water collection cup and turn it anticlockwise.



2. Remove the water collection cup.

### 12.2.2.12 Sample Gas Return Port

If your breathing system is configured with sample gas return port and this function is in use, depress the metal clip to release exhaust tube connector. Then pull out the connector. For details, refer to *8.3.5 Scavenge the Sample Gas* or *8.4.4 Scavenge the Sample Gas* or *9.8 Scavenge the Sample Gas*.

### 12.2.2.13 Breathing System

#### NOTE

- Disassemble breathing system with the tools shown as following picture.

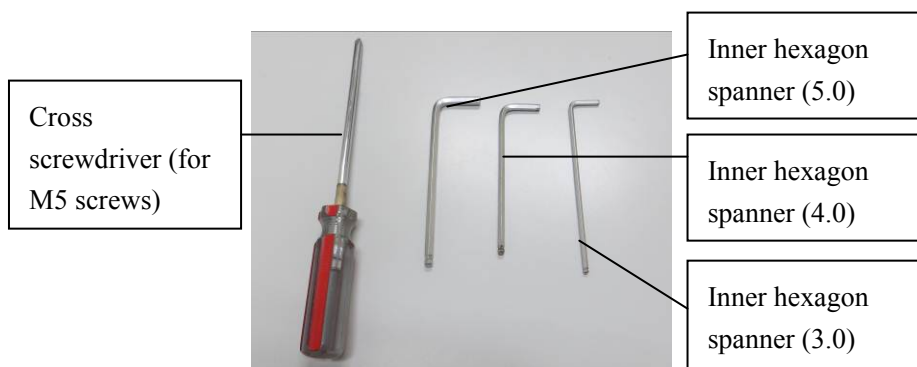

- 
1. Hold the breathing system with both hands. Depress the locking button with the right hand and pull out with force.

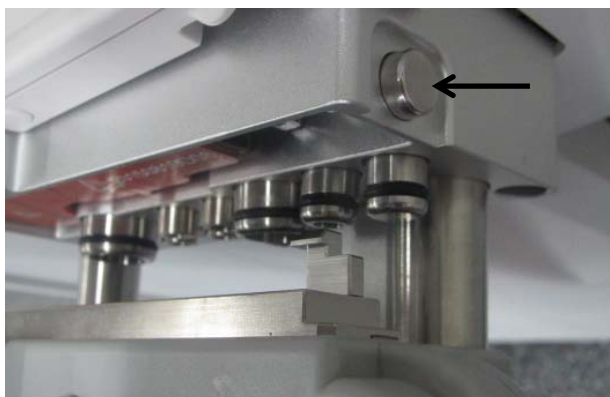

2. Remove the breathing system from the circuit adapter with both hands.

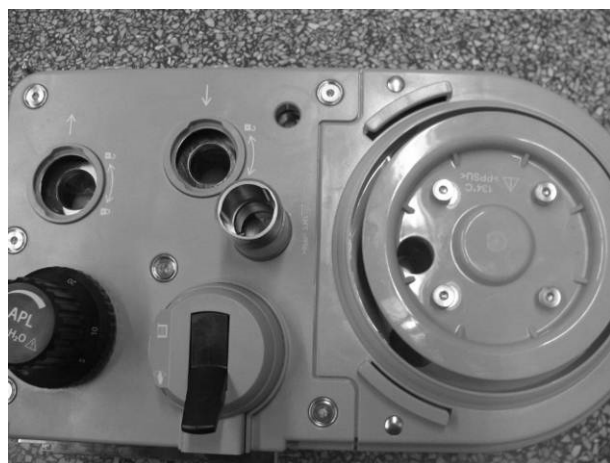



- 
3. Unscrew the three screws of the bellows base by inner hexagon spanner (3.0).



4. Lift off and remove the bellows base with the three screws.





5. Remove the seven screws on the lower cover panel by inner hexagon spanner (4.0).



Countersunk flat head screw M5\*25  
M5 spring washer and flat washer

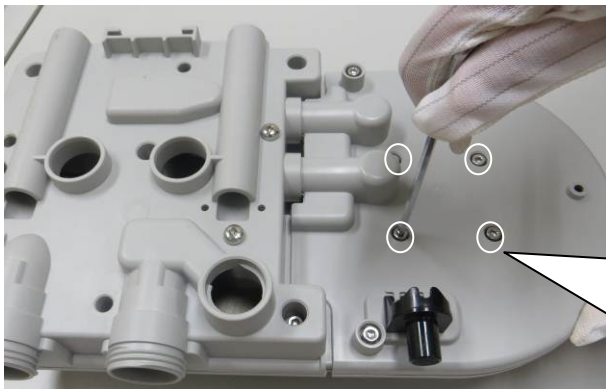

Hexagon lobular socket head cap  
screw M5\*20  
M5 spring washer and flat washer

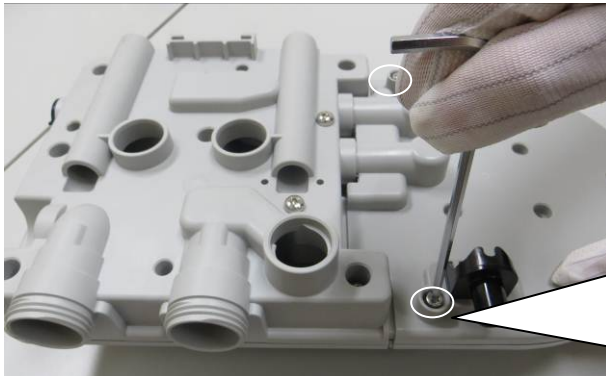

Hexagon lobular socket head cap  
screw M5\*25  
M5 spring washer and flat washer

6. Remove the upper part of bellows base.

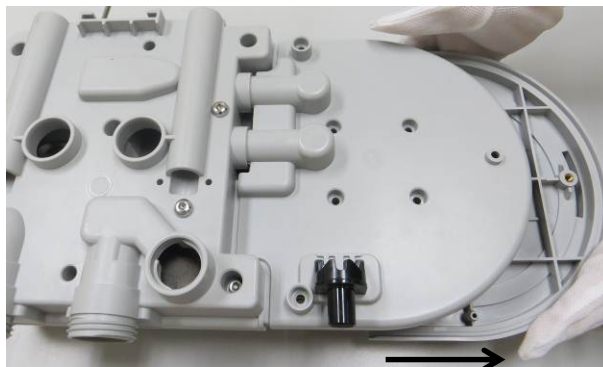

- 
7. Remove the lower cover panel.



8. Erect the breathing system, and remove the six screws on the upper and lower panel of gauge base by inner hexagon spanner (5.0) and inner hexagon spanner (4.0).

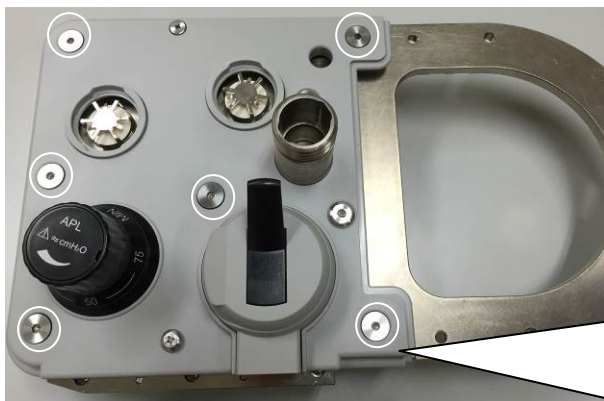

- Circuit upper panel nut
- Hexagon lobular socket head cap screw M5\*25
- M5 spring washer and flat washer

- 
9. Put the breathing system horizontally, and remove the two screws on the upper panel of gauge base by inner hexagon spanner (4.0).

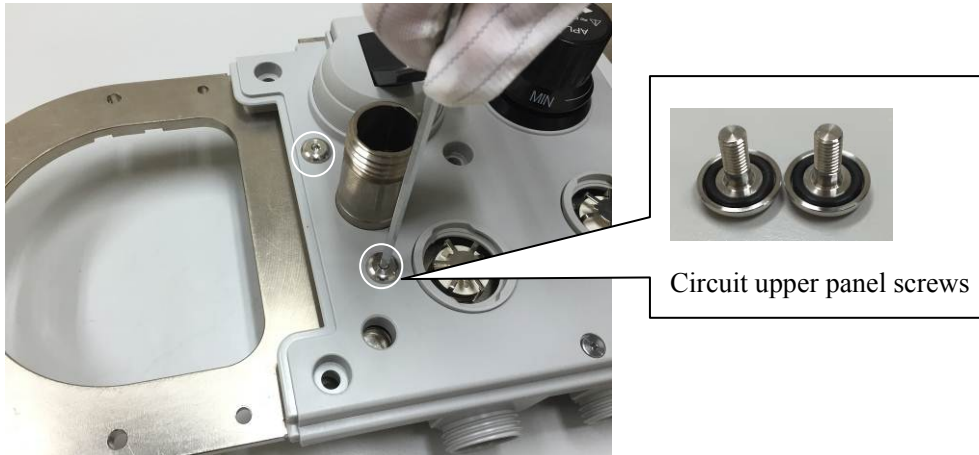

## NOTE

- Do not remove the sealing rings inside the circuit upper panel screws.
- 

10. Unscrew the other two screws on the upper panel of gauge base by Cross screwdriver.



- 
11. Remove the upper panel of gauges base.



12. Separate the metal plate and the lower panel of gauge base.

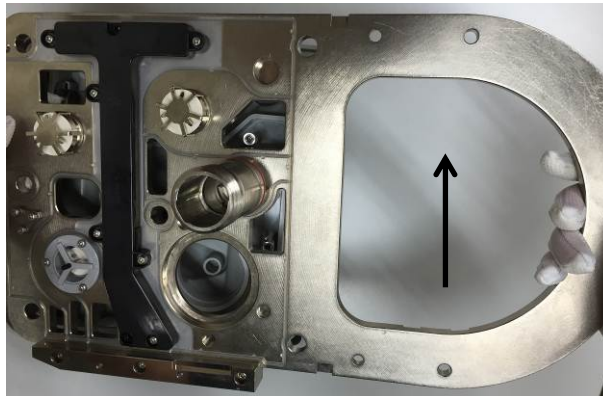

## NOTE

- 
- If it is hard to push the breathing system into or out of the circuit adapter, you need to apply some lubricant (M6F-020003--- : “Dupont Krytox high-performance fluorine lubricating grease” )to the seal on the pneumatic connector to reduce friction.
-

---

## 12.3 Clean & Disinfect and Re-install the Breathing System

Parts marked **134°C** are autoclavable. Metal and glass parts can be steam autoclaved. Maximum recommended temperature is 134°C. By using autoclave to solidify bacterioproducts rapidly, quick and reliable sterilization can be achieved.

Such parts are cleanable by hand. Rinse and dry all parts of the breathing system except the O<sub>2</sub> sensor completely by using mild detergent (pH ranging from 7.0 to 10.5).

The flow sensor is plastic. For details about cleaning procedure, refer to **12.3.4 Flow Sensor**.

---

### **WARNING**

---

- **Do not use talc, zinc stearate, calcium carbonate, corn starch or equivalent materials to prevent tackiness. These materials can go into the animal's lungs and airways and cause irritation or injury.**
  - **Do not put both of the breathing system or the O<sub>2</sub> sensor in liquid or autoclave them.**
  - **Inspect all parts for deterioration. Replace them if necessary.**
- 

All parts of the breathing system can be cleaned and disinfected. The cleaning and disinfection methods are different for different parts.

You need to select the appropriate method to clean and disinfect the parts based on the actual situations to avoid cross-contamination.

The table below lists the cleaning and disinfecting agents and autoclaving process that may be used on the anesthesia machine.

Name	Type
Ethanol (75%)	Moderately efficient disinfectant
Isopropanol (70%)	Moderately efficient disinfectant
Glutaraldehyde (2%)	Highly efficient disinfectant
Soap water (pH value of 7.0 to 10.5)	Cleaning agent
Clean water	Cleaning agent
Steam autoclave*	Highly efficient disinfection

Steam autoclave\*: All breathing system components are autoclavable except the PAW gauge, flow sensor and O<sub>2</sub> sensor. If the breathing system is configured with the autoclavable flow sensors, the flow sensors can be autoclaved. The components can be autoclaved up to a maximum temperature of 134°C (273°F) for 20 minutes (recommended time). Bellows can be autoclaved at 121°C (250°F) for 20 minutes or at 134°C (273°F) for 7 minutes (recommended time). Suction tubes and liquid collection bottles are not autoclavable.

Parts	Cleaning methods		Disinfection methods		
	1 Wipe	2 Immersion	A Wipe	B Immersion	C Steam autoclave
Breathing tubes and Y-piece		★		★	★
Breathing mask		★		★	★
Flow sensor		★		★	★ <sup>1</sup>
Airway Pressure Gauge	★		★		
Bellows assembly (not including bellows)		★		★	★
Bellows		★		★	★
Inspiratory and expiratory check valves assemblies		★		★	★
O <sub>2</sub> sensor	★		★		
Canister assembly		★		★	★
Canister connection block assembly		★		★	★
Water collection cup		★		★	★
Bag arm		★		★	★
BYPASS assembly		★		★	★
Breathing system		★		★	★
Manual bag		★		★	★

★ indicates applicable cleaning or disinfection method.

Cleaning methods:

1. Wipe: wipe with a damp cloth immersed in alkaline detergent (clean water or soap water with pH of 7.0 to 10.5) or alcohol solution and then wipe off the remaining detergent with a dry lint free cloth.
2. Immersion: flush with water first and then immersed in alkaline detergent (clean water or soap water with pH of 7.0 to 10.5) (water temperature 40°C recommended) for approximately three minutes. Finally clean with water and dry completely.

Disinfection methods:

- A. Wipe: wipe with a damp cloth immersed in medium- or high-efficiency detergent (such as 75% alcohol, 70% isopropanol, or 2% glutaraldehyde) solution and then wipe off the remaining detergent with a dry lint free cloth.
- B. Immersion: immersed in medium- or high-efficiency detergent (such as 75% alcohol, 70% isopropanol, or 2% glutaraldehyde) solution (immersion time varies according to the disinfectant). Then clean with water and dry in the air completely.
- C. Steam autoclave: Bellows are capable of being autoclaved at 121°C for 20 minutes or at 134°C for 7 minutes (recommended time). Other components of the breathing system are capable of being autoclaved at maximum 134°C for 20 minutes (recommended time).

Note: A and B belong to medium level disinfection and C to high level disinfection.

<sup>1</sup> If the breathing system is configured with the autoclavable flow sensors, the flow sensors can be autoclaved.



---

### 12.3.1 Breathing System

1. Ensure that the above-mentioned assemblies are disassembled. Then refer to methods recommended in the table of *12.3 Clean & Disinfect and Re-install the Breathing System* to clean and disinfect the breathing system.



Breathing System Not Compatible with Pre-Pak

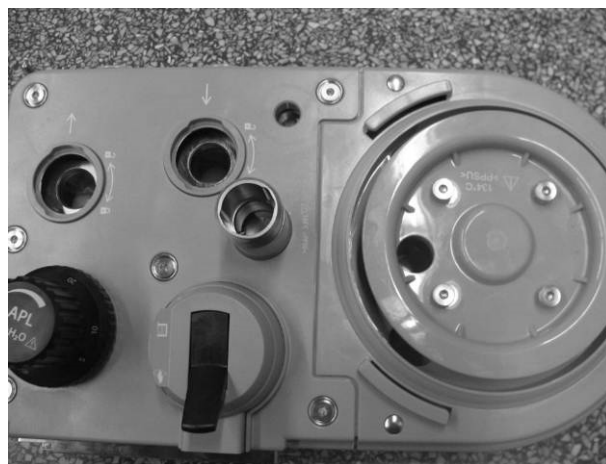

Breathing System Compatible with Pre-Pak

2. Ensure that the breathing system is fully dry before installing it with reference to *11.1.1.3 Install the Breathing system or 11.1.2.3 Install the Breathing System*.

#### NOTE

- Pay attention when installing the lower cover panel. Do not confuse hexagon lobular socket head cap screw M5\*20 and hexagon lobular socket head cap screw M5\*25.
  - Operate breathing system leak test after installing the breathing system.
-

---

## 12.3.2 Water Collection Cup

1. Refer to the methods recommended in the table of *12.3 Clean & Disinfect and Re-install the Breathing System* to clean and disinfect the water collection cup.
2. Ensure that the water collection cup is fully dry before installing it with reference to *12.2.1.11 Water Collection Cup* or *12.2.2.11 Water Collection Cup* in the reverse order:
  - Align the water collection cup with the matching threaded hole on the breathing system.
  - Turn the water collection cup clockwise to tighten it.

## 12.3.3 Inspiratory and Expiratory Check Valves Assembly

1. Refer to the methods recommended in the table of *12.3 Clean & Disinfect and Re-install the Breathing System* to clean and disinfect the inspiratory and expiratory check valves assembly.
2. Immerse the check valves and their covers in the disinfectant or autoclave them. Maximum recommended temperature is 134°C.
3. After they are fully dry, install the inspiratory and expiratory check valves with reference to *12.2.1.8 Expiratory Check Valve Assembly*, *12.2.1.9 Inspiratory Check Valve Assembly*, *12.2.2.8 Expiratory Check Valve Assembly*, and *12.2.2.9 Inspiratory Check Valve Assembly* in the reverse order. Push the check valve into the breathing system and then turn the valve cover clockwise to tighten it.

---

### **WARNING**

---

- **Do not separate the check valve diaphragm from the valve cover.**
  - **When installing the check valve, depress the valve forcibly to ensure that it is installed in position.**
- 

## 12.3.4 Flow Sensor

It is recommended to clean the flow sensor as determined by your hospital's policy. Or you can refer to the methods recommended in the table of *12.3 Clean & Disinfect and Re-install the Breathing System* to clean and disinfect the flow sensor.



---

---

 **CAUTION**

---

- **Do not autoclave the flow sensor. If the breathing system is configured with the autoclavable flow sensors, the flow sensors can be autoclaved.**
  - **Do not use high pressure gas or brushes to clean the flow sensor.**
  - **Do not use cleaning solvents that are not approved for use with polycarbonates.**
  - **Do not clean the interior surface of the flow sensor. Use a damp cloth on the external surface only.**
- 

1. Submerge the flow sensor in the disinfectant solution for the disinfection period.
  2. Rinse the flow sensor with clean water.
  3. Completely dry the flow sensor before use.
  4. Refer to *12.2.1.7 Flow Sensor* or *12.2.2.7 Flow Sensor* to install the flow sensor in the reverse order.
- 

---

---

 **WARNING**

---

- **Tighten the locking nuts when installing the flow sensor. Failure to do so may result in invalid measurement.**
  - **The end of inspiration/expiration connectors which connects the breathing tube shall be kept downward to prevent condensed water from entering the breathing system.**
- 

### 12.3.5 Bellows Assembly

---

 **CAUTION**

---

- **Do not soak the bellows assembly in warm water and cleaning solution for more than 15 min. Swelling or faster aging can occur.**
  - **When exposing the bellows to air dry, hang and outspread it fully to prevent tackiness.**
  - **Before installing the bellows housing, check if the sealing component on the breathing system is normal. If it is coming off or tilting, install it properly first.**
-

---

## NOTE

---

- **Disassemble the bellows assembly before cleaning it. If not, it will take a very long time to dry.**
  - **If autoclaving is necessary, assemble the bellows assembly first. Turn over the bellows assembly to autoclave it.**
- 

1. Refer to the methods recommended in the table of *12.3 Clean & Disinfect and Re-install the Breathing* System to clean and disinfect the bellows assembly.
2. Place the bellows assembly in warm (40°C recommended temperature) mild detergent (such as soap water). Carefully wash the assembly to prevent damage of the parts.
3. Rinse the assembly with clean warm water.
4. Autoclave the cleaned bellows housing. Maximum recommended temperature is 134°C.
5. Hang the disinfected bellows assembly upside down and dry at a room temperature less than 70°C.
6. Look for damaged parts after the bellows assembly is fully dry. Then install the assembly with reference to *11.1.1.5 Install the Bellows* or *11.1.2.5 Install the Bellows*.
7. Connect the bellows assembly, ventilator and breathing system.
8. Perform preoperative test before system use. For details, refer to *6.12.1 Bellows Test*.

### 12.3.6 Airway Pressure Gauge

1. Refer to the methods recommended in the table of *12.3 Clean & Disinfect and Re-install the Breathing* System to clean and disinfect the airway pressure gauge.
2. When the airway pressure gauge is fully dry, refer to *12.2.1.4 Airway Pressure Gauge* or *12.2.2.4 Airway Pressure Gauge* to install it in the reverse order.

### 12.3.7 Bag Arm

1. Refer to the methods recommended in the table of *12.3 Clean & Disinfect and Re-install the Breathing* System to clean and disinfect the bag arm.
2. Ensure that the bag arm is fully dry before installing it with reference to *12.2.1.5 Bag Arm* or *12.2.2.5 Bag Arm in the* reverse order.

---

## 12.3.8 Breathing Tubes and Y-Piece

### NOTE

---

- **When installing or cleaning the breathing tube, hold the tube connectors at both ends of the tube to prevent damage to the tube.**
- 
1. Refer to the methods recommended in the table of *12.3 Clean & Disinfect and Re-install the Breathing System* to clean and disinfect the breathing tubes and Y-piece.
  2. When the breathing tubes and Y-piece are fully dry, install them onto the breathing system with reference to *12.2.1.3 Breathing Tubes* or *12.2.2.3 Breathing Tubes* in the reverse order.

## 12.3.9 Manual Bag

1. Refer to the methods recommended in the table of *12.3 Clean & Disinfect and Re-install the Breathing System* to clean and disinfect the manual bag.
2. When the manual bag is fully dry, refer to *12.2.1.2 Manual Bag* or *12.2.2.2 Manual Bag* to install it in the reverse order.

## 12.3.10 O<sub>2</sub> Sensor

---

### WARNING

---

- **Do not put the breathing system or the O<sub>2</sub> sensor in liquid or autoclave them.**
  - **Water vapor may condense on the surface of the O<sub>2</sub> sensor, which can result in invalid O<sub>2</sub> concentration measurement. In this case, you need to take out the O<sub>2</sub> sensor, remove the water condensed on its surface, and reinstall it into the breathing system.**
- 
1. Refer to the methods recommended in the table of *12.3 Clean & Disinfect and Re-install the Breathing System* to clean and disinfect the O<sub>2</sub> sensor.
  2. When the O<sub>2</sub> sensor is fully dry, refer to *11.1.1.7 Install the O<sub>2</sub> Sensor* or *11.1.2.7 Install the O<sub>2</sub> Sensor*.

---

### 12.3.11 CO<sub>2</sub> Absorbent Canister

#### NOTE

- 
- It is recommended to apply the high level disinfection procedure after the intermediate level disinfection is completed.
- 
1. Refer to the methods recommended in the table of *12.3 Clean & Disinfect and Re-install the Breathing System* to clean and disinfect the CO<sub>2</sub> absorbent canister.
  2. Pour the absorbent into the CO<sub>2</sub> absorbent canister when the canister is fully dry.
  3. Refer to *11.1.1.8 Install the CO<sub>2</sub> Absorbent Canister* or *11.1.2.8 Install the Soda-lime container or CO<sub>2</sub> Absorbent Canister* to install the canister onto the breathing system.

### 12.3.12 Breathing Mask

Refer to the methods recommended in the table of *12.3 Clean & Disinfect and Re-install the Breathing System* to clean and disinfect the breathing mask.

## 12.4 AGSS Transfer and Receiving System

1. Disconnect the EVAC hose from the AGSS. Remove the AGSS and Transfer Hose from the main unit.

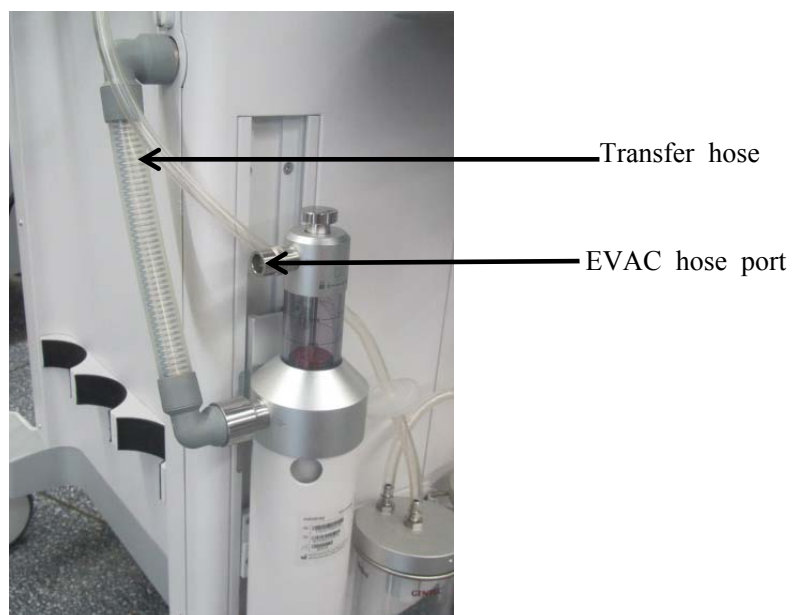

- 
2. Rotate the top cover counterclockwise to separate the top cover from the window.



3. Clean the outer surface of the AGSS and Transfer Hose with a soft, lint-free cloth and a recommended cleaning agent. Allow to dry thoroughly.
4. Remove the top of the AGSS. Inspect the AGSS filter and shake it over a waste container to clean it as necessary. If the filter must be replaced, dispose of the old filter per local disposal regulations.



---

**⚠ WARNING**

- Do not autoclave the AGSS.
-

---

## 12.5 Negative Pressure Suction Device

Pull out the suction tubes, remove the liquid collection bottles, and reject the filter. Flush the suction tubes and liquid collection bottles with clean water. Then soak them in the solution (40°C recommended) of water and alkaline detergent (40°C recommended) for approximately three minutes. Finally clean them with clean water and wipe with 70% ethanol.

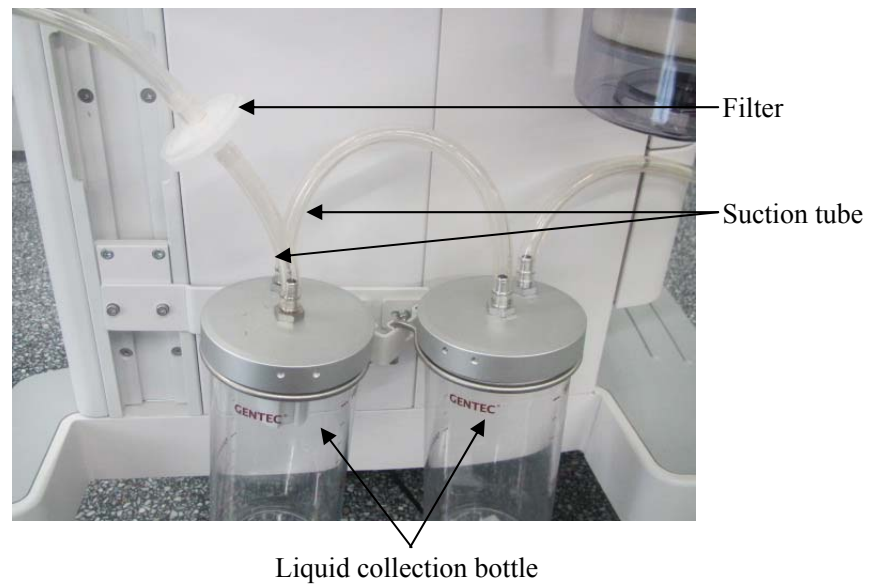

# 13 Accessories

## WARNING

- Use only accessories specified in this chapter. Using other accessories may cause incorrect measured valued or equipment damage.
- Disposable accessories cannot be reused. Reuse may degrade performance or cause cross-contamination.
- Check the accessories and their packages for damage. Do not use them if any sign of damage is detected.
- Parts which are intended to contact animals must comply with the biocompatibility requirement of ISO10993-1 to prevent any adverse reactions arising from such contact.
- Disposal of the accessories shall comply with the applicable waste control regulations.

Description	PN
<b>Connector</b>	
L connector 22F, 22M/15F, durable	040-001868-00
Y connector, durable	040-001866-00
<b>Manual Bag</b>	
Latex-Free Breathing Bag 0.5 Liter, disposable	040-001827-00
Latex-Free Breathing Bag 1 Liter, disposable	040-001828-00
Latex-Free Breathing Bag 2 Liter, disposable	040-001829-00
Latex-Free Breathing Bag 3 Liter, disposable	040-001830-00
Silicone Breathing Bag 0.5 Liter	040-001856-00
Silicone Breathing Bag 1 Liter	040-001857-00
Silicone Breathing Bag 2 Liter	040-001858-00
Silicone Breathing Bag 3 Liter	040-001859-00
<b>Breathing Tube</b>	
Silicone breathing tube, adult, 150 cm	040-001850-00
Silicone breathing tube, pediatric/infant, 150 cm	040-001851-00
Silicone breathing tube, adult, 45 cm	040-001854-0

Pediatric breathing tube kit (including 150 cm breathing tube, L connector, backup breathing tube, straight connector, filter, 1 Liter latex-free manual bag), disposable	040-001878-00
Adult breathing tube kit (including 150 cm breathing tube, L connector, backup breathing tube, straight connector, filter, 3 Liter latex-free manual bag), disposable	040-001876-00
<b>CO<sub>2</sub> Module</b>	
Main unit kit of Single-groove CO <sub>2</sub> module (with adult/pediatric accessories)	115-024797-00
Main unit kit of Single-groove CO <sub>2</sub> module (with neonatal accessories)	115-024798-00
CAPNOSTAT CO <sub>2</sub> module upgrade package (with accessories)	115-030410-00
ORIDION CO <sub>2</sub> module upgrade package (with accessories)	115-030412-00
Main unit kit of CAPNOSTAT CO <sub>2</sub> module (without accessories)	115-030414-00
Main unit kit of ORIDION CO <sub>2</sub> module (without accessories)	115-030416-00
Main unit kit of M02D CO <sub>2</sub> module (without accessories)	120-013811-00
Mainstream CAPNOSTAT 5 CO <sub>2</sub> accessory package	6800-30-50613
Microstream CO <sub>2</sub> accessory package	0621-30-69426
Single-slot CO <sub>2</sub> accessory package (adult/pediatric)	115-024752-00
Single-slot CO <sub>2</sub> accessory package (neonatal)	115-024753-00
<b>AG Module</b>	
Main unit kit of AG module (with O <sub>2</sub> ) (without accessories)	115-001698-00
Main unit kit of AG module (without O <sub>2</sub> ) (without accessories)	115-013204-00
AG module upgrade package (with O <sub>2</sub> ) (with accessories)	115-030400-00
AG module upgrade package (without O <sub>2</sub> ) (with accessories)	115-030401-00
AG module accessory package	0621-30-69686
Main unit kit of AG module, dual-slot (with O <sub>2</sub> ) (without accessories)	115-030368-00
Main unit kit of AG module, dual-slot (without O <sub>2</sub> ) (without accessories)	115-030369-00
AG module upgrade package , dual-slot (with O <sub>2</sub> ) (with accessories)	115-030379-00
AG module upgrade package , dual-slot (without O <sub>2</sub> ) (with accessories)	115-030380-00
AG module accessory package, dual-slot	115-030385-00
<b>Mask</b>	
Aircushion Mask, # 0, disposable (including aircushion and hook)	040-001817-00
Aircushion Mask, # 1, disposable (including aircushion and hook)	040-001818-00
Aircushion Mask, # 2, disposable (including aircushion and hook)	040-001819-00
Aircushion Mask, # 3, disposable (including aircushion and hook)	040-001820-00
Aircushion Mask, # 4, disposable (including aircushion and hook)	040-001821-00



Aircushion Mask, # 5, disposable (including aircushion and hook)	040-001822-00
Mask. Silicone, # 0, unibody	040-001835-00
Mask. Silicone, # 1, unibody	040-001836-00
Mask. Silicone, # 2, unibody	040-001837-00
Mask. Economy Silicone, # 3, assembly-type, durable	040-001841-00
Mask. Economy Silicone, # 4, assembly-type, durable	040-001842-00
Mask. Economy Silicone, # 5, assembly-type, durable	040-001843-00
<b>O<sub>2</sub> Sensor</b>	
O <sub>2</sub> sensor	040-000898-00
Cable of O <sub>2</sub> sensor	0601-20-78941
<b>Anesthetic Vaporizer</b>	
Vaporizer, Isoflurane 5% Selectatec, Key Filler	0621-30-78727
Vaporizer, Sevoflurane 8% Selectatec, Key Filler	115-002355-00
Vaporizer, Halothane 5% Selectatec, Key Filler	115-002356-00
Vaporizer, Sevoflurane 8% Selectatec, Quick Fil	M6Q-130008---
Vaporizer material kit, Isoflurane, Key Filler	115-005345-00
Vaporizer material kit, Sevoflurane, Key Filler	115-005346-00
Vaporizer material kit, Sevoflurane, Quick Fil	115-005350-00
Vaporizer material kit, Halothane, Key Filler	115-014138-00
Key Filler Adaptor for Halothane 53450	040-000063-00
Key Filler Adaptor for Enflurane 53452	040-000064-00
Key Filler Adaptor for Isoflurane 53453	040-000065-00
Key Filler Adaptor for Sevoflurane 53454	040-000066-00
Quik-Fil Drain Funnel Adaptor 54909	040-000067-00
Sevoflurane Quik-Fil Adaptor assembly (0605)	115-026747-00
<b>AGSS</b>	
AGSS low-flow active scavenging hose assembly (hose connecting the hospital's waste gas disposal system to the AGSS main unit. Hose length: approximately 4m)	115-009073-00
AGSS high-flow active scavenging hose assembly (hose connecting the hospital's waste gas disposal system to the AGSS main unit. Hose length: approximately 4m)	115-009097-00
Passive scavenging hose material kit	115-002342-00
AGSS transfer tube assembly (0631)	115-006557-00
AGSS positive scavenging hose (35G-WAGD-DS/FG2-3)	082-001372-00

AGSS British-standard connection material kit	115-020745-00
AGSS material kit (0634 low flow/international)	115-030332-00
AGSS material kit (0634 high flow/international)	115-030333-00
AGSS assembly (0631 high flow/new silk-screen)	115-017375-00
AGSS assembly (0631 low flow/new silk-screen)	115-017376-00
<b>Patient Monitor Bracket Assembly</b>	
T5 patient monitor fixed mounting assembly	115-004004-00
T8 patient monitor fixed mounting assembly	115-004003-00
GCX patient monitor bracket material kit (7000/8000)	115-015769-00
GCX patient monitor bracket material kit (6802/9000)	115-015770-00
GCX patient monitor bracket material kit (6800)	115-015783-00
GCX patient monitor bracket and module rack bracket material kit (6802)	115-015771-00
GCX patient monitor bracket and module rack bracket material kit (6800)	115-015784-00
GCX patient monitor bracket material kit (IMEC, new iPM)	115-015786-00
<b>Gas Source Hose</b>	
O <sub>2</sub> supply hose assembly, European-standard, 34I-OXY-BS/NS-5	082-001209-00
Air supply hose assembly, European-standard, 34I-AIR-BS/NS-5	082-001210-00
N <sub>2</sub> O supply hose assembly, European-standard, 34I-N2O-BS/NS-5	082-001211-00
O <sub>2</sub> supply hose assembly, German-standard, 34I-OXY-GS/NS-5	082-001212-00
Air supply hose assembly, German-standard, 34I-AIR-GS/NS-5	082-001213-00
N <sub>2</sub> O supply hose assembly, German-standard, 34I-N2O-GS/NS-5	082-001214-00
O <sub>2</sub> supply hose assembly, Australian-standard, 34I-OXY-SIS/NS-5	082-001215-00
Air supply hose assembly, Australian-standard, 34I-AIR-SIS/NS-5	082-001216-00
N <sub>2</sub> O supply hose assembly, Australian-standard, 34I-N2O-SIS/NS-5	082-001217-00
O <sub>2</sub> supply hose assembly, French-standard, 34I-OXY-FS/NS-5	082-001218-00
Air supply hose assembly, French-standard, 34I-AIR-FS/NS-5	082-001219-00
N <sub>2</sub> O supply hose assembly, French-standard, 34I-N2O-FS/NS-5	082-001220-00
O <sub>2</sub> supply hose assembly, American-standard, 34U-OXY-DS-5	082-001224-00
Air supply hose assembly, American –standard, 34U-AIR-DS-5	082-001225-00
N <sub>2</sub> O supply hose assembly, American –standard, 34U-N2O-DS-5	082-001226-00
O <sub>2</sub> supply hose assembly, American-standard, 34U-OXY-BS/DS-5	082-001227-00
Air supply hose assembly, American –standard, 34U-AIR-BS/DS-5	082-001228-00
N <sub>2</sub> O supply hose assembly, American –standard, 34U-N2O-BS/DS-5	082-001229-00
N <sub>2</sub> O supply hose assembly, American –standard, Chemetron,	082-001354-00

34U-N2O-CH/DS-5	
Air supply hose assembly, American –standard, Chemetron, 34U-AIR-CH/DS-5	082-001355-00
O <sub>2</sub> supply hose assembly, American-standard, Chemetron, 34U-OXY-CH/DS-5	082-001356-00
N <sub>2</sub> O supply hose assembly, American –standard, Ohmeda, 34U-N2O-OH/DS-5	082-001373-00
Air supply hose assembly, American –standard, Ohmeda, 34U-AIR-OH/DS-5	082-001374-00
O <sub>2</sub> supply hose assembly, American-standard, Ohmeda 34U-OXY-OH/DS-5	082-001376-00
O <sub>2</sub> supply hose assembly, American-standard, P-B 34U-OXY-PB/DS-5	082-001375-00
N <sub>2</sub> O supply hose assembly, American –standard, P-B 34U-N2O-PB/DS-5	082-001377-00
Air supply hose assembly, American –standard, P-B 34U-AIR-PB/DS-5	082-001378-00
Connector of gas nozzle	0611-20-58778
Nut of O <sub>2</sub> gas nozzle	0611-20-58779
Nut of N <sub>2</sub> O gas nozzle	0611-20-58839
Clamp, size range of 9.5 mm to 12 mm, galvanized	M90-000149---
<b>Negative Pressure Suction</b>	
Negative pressure suction material kit (driven by Air NIST)	115-041470-00
Negative pressure suction material kit (driven by Air DISS)	115-041471-00
Pipe-type negative pressure suction material kit (American-standard/Diss)	115-041474-00
Pipe-type negative pressure suction material kit (American-standard/PB)	115-041475-00
Pipe-type negative pressure suction material kit (American-standard/ ohmeda)	115-041476-00
Pipe-type negative pressure suction material kit (American-standard/ Chemetron)	115-041477-00
Pipe-type negative pressure suction material kit (American-standard/ British-standard)	115-041478-00
Pipe-type negative pressure suction material kit(Australian-standard)	115-041479-00
Pipe-type negative pressure suction material kit(Frence-standard)	115-041480-00
Pipe-type negative pressure suction material kit(German-standard)	115-041481-00
Pipe-type negative pressure suction material kit(British-standard)	115-041482-00
<b>Flow Sensor</b>	
Inspiratory flow sensor assembly	0601-30-69700
Expiratory flow sensor assembly	0601-30-78894
Flow sensor assembly	115-001366-00
Flow sensor assembly (steam autoclave)	115-041519-00

Expiratory flow sensor assembly (steam autoclave)	115-041508-00
Inspiratory flow sensor assembly (steam autoclave)	115-041507-00
<b>Battery</b>	
Lithium-Ion battery material kit, 11.1 V, 4500 mAh, LI23S002A	115-018012-00
<b>Support Arm</b>	
Support arm material kit (0634)	115-024461-00
Cord collector material kit (for support arm)	115-024056-00
M series support arm material kit (with cable manager)	115-024614-00
<b>Accessory Package</b>	
Durable accessory package, adult (without flow sensor)	115-031780-00
Durable accessory package, child (without flow sensor)	115-031781-00
Disposable accessory package, adult (without flow sensor)	115-030717-00
Disposable accessory package, child (without flow sensor)	115-030718-00
<b>Circuit</b>	
Mapleson D circuit	040-001702-00
T-piece system circuit	040-001703-00
Mapleson C circuit	040-001704-00
<b>Others</b>	
Air compressor cart material kit	115-014961-00
Backup vaporizer bracket material kit	115-017631-00
Hook material kit (0632)	115-021015-00
Cable tie accessory package	115-011304-00
SPECIAL SEAL	0348-00-0185

# A Theory of Operation

## A.1 Pneumatic Circuit System

### A.1.1 Pneumatic Circuit Diagram

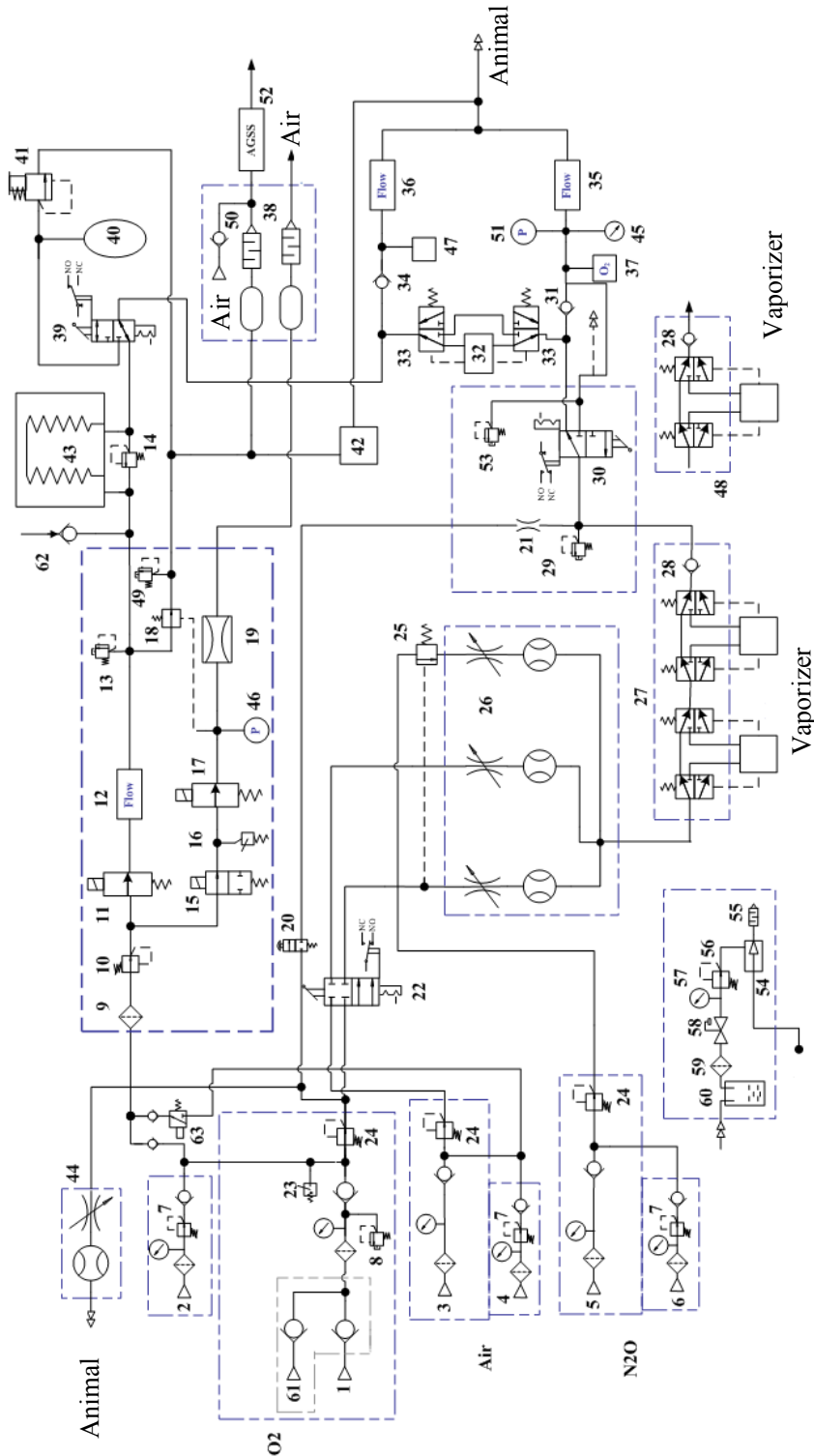

## A.1.2 Parts List

1	O <sub>2</sub> Pipeline	33	BYPASS stop valve
2	O <sub>2</sub> cylinder	34	Expiratory check valve
3	Air Pipeline	35	Inspiratory flow sensor
4	Air cylinder	36	Expiratory flow sensor
5	N <sub>2</sub> O Pipeline	37	O <sub>2</sub> sensor
6	N <sub>2</sub> O cylinder	38	Scavenging reservoir and sound arrestor
7	Regulator (0.4 MPa)	39	Auto/Manual switch
8	Pressure relief valve (0.758 MPa)	40	Manual bag
9	Filter	41	APL valve
10	Regulator (0.2 MPa)	42	Anesthetic gas module
11	Inspiratory flow control valve	43	Bellows assembly
12	Flow sensor (Venturi)	44	Auxiliary O <sub>2</sub> supply
13	Mechanical overpressure valve (110 cmH <sub>2</sub> O)	45	Airway pressure gauge
14	Pop-Off valve	46	Pressure sensor
15	PEEP safety valve	47	Water collection cup
16	Pressure switch (140 kPa)	48	Single-vaporizer manifold
17	Proportional PEEP valve	49	Pressure relief valve (10 cmH <sub>2</sub> O)
18	Expiratory valve	50	Negative pressure valve (1 cmH <sub>2</sub> O)
19	Pneumatic resistor	51	Pressure sensor
20	O <sub>2</sub> flush valve	52	AGSS
21	Flow restrictor	53	Pressure relief valve (11 kPa)
22	System switch	54	Venturi negative pressure generator
23	Pressure switch (0.2 MPa)	55	Muffler
24	Regulator (0.2 MPa)	56	Positive pressure valve (1KPa)
25	O <sub>2</sub> -N <sub>2</sub> O cut-off valve (0.1 MPa)	57	Adjustable negative pressure gauge
26	Flowmeter	58	Floating overfill protection valve
27	Double-vaporizer manifold	59	Negative pressure suction filter
28	Check valve	60	Liquid collection bottle
29	Pressure relief valve (38 kPa)	61	Backup oxygen supply inlet
30	ACGO selector switch	62	Free respiratory valve
31	Inspiratory check valve	63	Drive gas switch
32	Soda-lime container or CO <sub>2</sub> absorbent canister	64	/

---

### A.1.3 Description

The pneumatic system diagram is shown as follows, including anesthesia delivery system, vaporizer, anesthetic ventilator, and AGSS transfer and receiving system.

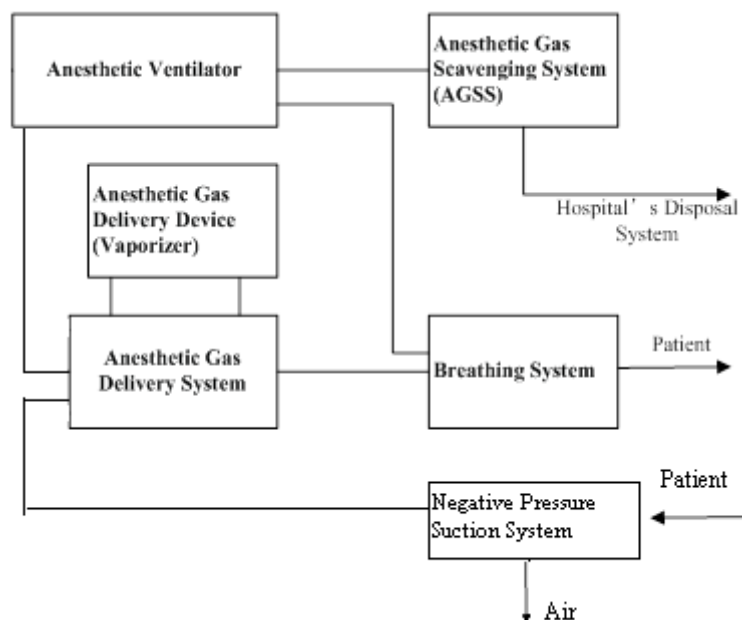

### Anesthesia Delivery System

The purpose of the anesthesia delivery system is to generate anesthetic mixed gas (fresh gas). Three types of supply gases are available:  $N_2O$ ,  $O_2$ , and Air. The user adjusts supply gas flows through the flowmeters. The mixed gas output from the flowmeters is further mixed with the anesthetic agent inside the anesthetic vaporizer to form the fresh gas. In addition to the fresh gas, anesthesia machine provides other two gas outputs: auxiliary  $O_2$  supply and  $O_2$  flush supply.

The input  $O_2$  splits into auxiliary  $O_2$  supply 44, drive gas switch 63,  $O_2$  flush valve 20, and system switch 22. The input Air splits into system switch 22, and drive gas switch 63. The input  $N_2O$  goes into the system through flow control assembly (flow regulator) 26 directly, not through the system switch, and there it is mixed with  $O_2$  and Air which come from the system switch. The mixed gas goes into the anesthetic gas delivery device. The drive gas switch 63 switches the drive gas to  $O_2$  or Air through system settings or system automatic decision.

After opening the system switch 22,  $O_2$ ,  $N_2O$  and Air pass through flow control and display system, and go in to the anesthetic gas delivery device (Vaporizer). The vaporizer bracket is integrated with the check valve 28, to prevent the pressures of  $O_2$  flush supply and rear-end fresh gas from affecting the anesthetic concentration output. The double-vaporizer manifold 27 prevents the user to open two vaporizers at the same time by Selectatec® interlocking function. The mixed gases with anesthetic agent pass through the check valve 28 and the ACGO selector switch 30 to deliver anesthetic gas.

By activating ACGO, the fresh gas can go out from ACGO outlet directly, not passing through the CO<sub>2</sub> absorbent canister in the breathing system, so the fresh gas can be delivered into the auxiliary manual breathing circuit.

## Anesthetic Gas Delivery Device

The anesthetic gas delivery device (vaporizer) can offer anesthetic vapor of controllable concentration. It has temperature compensation, flow compensation and pressure compensation functions. And it can support Enflurane, Isoflurane, Halothane and Sevoflurane.

## Anesthetic Ventilator

This anesthetic ventilator is a pneumatically driven, microprocessor-controlled anesthesia delivery system. The purpose of the anesthetic ventilator is to provide driving force for the animal's breathing procedure.

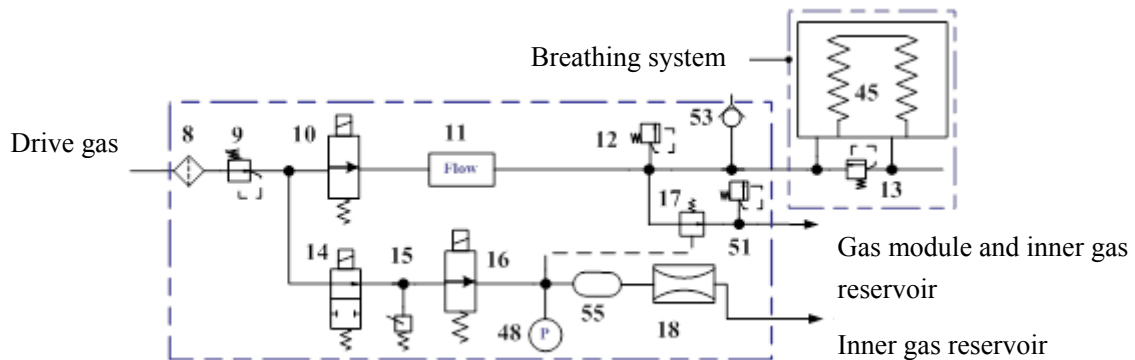

The drive gas comes from O<sub>2</sub> or Air gas supply. Filter 8 filters the drive gas again. Regulator 9 helps to keep the drive gas pressure to stay within a fixed pressure range (about 0.2Mpa). Inspiratory flow control valve 10 controls the inspiratory flow. Flow sensor 11 monitors the flow of drive gas. The ventilator has a built-in pressure safety valve 12 which opens when the inspiratory pressure exceeds approximately 110 cmH<sub>2</sub>O (11 kPa) to avoid sustained airway pressure. The drive gas from outside of bellows is removed through expiratory valve 17 during the expiration phase.

PEEP is achieved by the expiratory valve controlling the branch. When the proportional PEEP valve 16 opens, some gas will be output from pneumatic resistor 18, and there will be a relatively stable pressure, which is applied onto the expiratory valve membrane of the expiratory valve 17, in the airway between the proportional PEEP valve 16 and pneumatic resistor 18.



To prevent the pressure in the airway to be too high, the PEEP safety valve 14 is added in the front of expiratory valve controlling branch. The PEEP safety valve 14 is to control the on-off of expiratory valve controlling branch, to prevent the high pressure to hurt the animal and damage the device. 15 is pressure switch. When the pressure of drive gas is lower than 140 kPa, alarm will be triggered. Pressure sensor 48 monitors the pressure of expiratory valve 17. Pressure relief valve 51 ensures the pressure of the pipeline after the expiratory valve 17 is lower than 10 cmH<sub>2</sub>O in expiration phase.

## Breathing System

The breathing system offers a closed loop for anesthetic gas. The CO<sub>2</sub> that the animal breathes out can be absorbed in inspiration phase, to ensure the exhaled gas to be inspired again to keep the temperature and humidity condition of the gas. During inspiration phase, the drive gas compresses the bellows to push the gas into animal's lung; during expiration phase, the animal pushes the gas from the lung into the bellow, the CO<sub>2</sub> absorbent canister 32 of the circuit absorbs the CO<sub>2</sub> from exhaled gas that is pushed from bellows during inspiration..

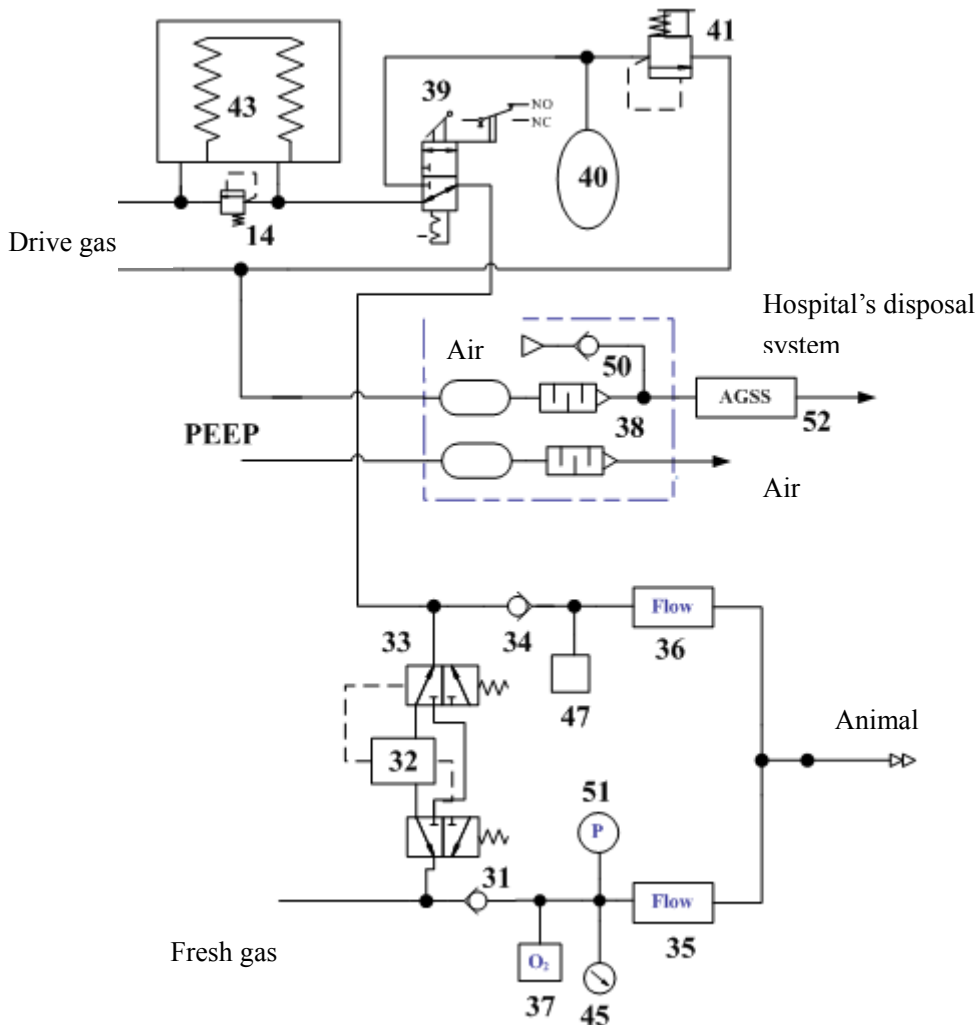

---

Enter manual ventilation or mechanical ventilation mode by setting Auto/Manual switch 39, a corresponding electric signal is send to main board.

In manual ventilation mode, the doctor presses the manual bag 40 to offer gas supply. The gas passes through Auto/Manual switch 39, BYPASS stop valve 33, Soda-lime container 32, and then inspiratory check valve 31 with the fresh gas from ACGO, O<sub>2</sub> sensor 37, airway pressure gauge 45 and inspiratory flow sensor 35, and goes into animal's lung. During expiration phase, the gas passes through expiratory flow sensor 36, expiratory check valve 34 and Auto/Manual switch 39, APL valve 41, and back into the AGSS.

In mechanical ventilation mode, the drive gas presses the bellows in the bellows assembly 43 to offer gas supply for the breathing system. During inspiration phase, the gas passes through Auto/Manual switch 39, BYPASS stop valve 35, CO<sub>2</sub> absorbent canister 32, inspiratory check valve 31, airway pressure gauge 45 and inspiratory flow sensor 35, and goes into animal's lung. During expiration phase, the gas passes through expiratory flow sensor 36, expiratory check valve 34 and Auto/Manual switch 39, and back into the AGSS.

### **Anesthetic Gas Scavenging System (AGSS)**

Anesthetic Gas Scavenging System (AGSS) includes AGSS transfer system, AGSS receiving system and AGSS disposal system. It transfers the waste gas from the scavenging assembly of the anesthesia machine and output it into the hospital's disposal system (AGSS processing system).

### **Negative Pressure Suction System**

The negative pressure suction system suctions the animal's pharyngeal fluid and vomit. External negative pressure suction system includes drive gas hose, venturi negative pressure generator, negative pressure regulator, overflow protection cup, filter, and water collector.

---

## A.2 Electrical System Structure

### A.2.1 Electrical Block Diagram

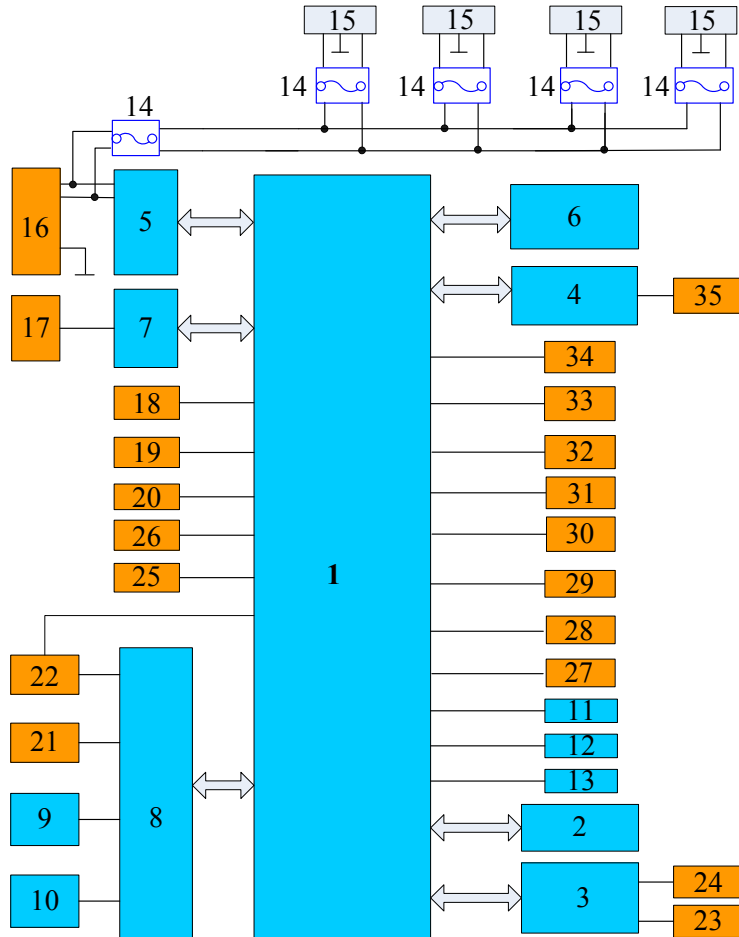

---

## A.2.2 Parts List

1	Motherboard	19	System switch
2	Infrared communication board	20	Fan for module rack
3	Top light board	21	Touch panel
4	Monitoring module	22	Display
5	Power board	23	Speaker
6	Main control board	24	Top light switch
7	Battery transfer board	25	Driving gas 3-way valve
8	Key control board	26	Heating module
9	Key and alarm light board	27	ACGO switch
10	Copper axis encoder board	28	AIR supply inlet pressure switch
11	Indicator light board	29	O2 supply inlet pressure switch
12	Back-light of flow-meter	30	O2 sensor
13	Auxiliary lighting board	31	Auto/Manual switch
14	Fuse	32	Circuit in-position switch
15	Auxiliary electrical outlet	33	Switch for CO2 absorbent canister
16	AC mains inlet	34	Pneumatic block
17	Lithium battery	35	Three-way valve assembly
18	Cooling fan	/	/

# **B** Product Specifications

---

---

The anesthesia machine shall be used together with the monitoring devices, alarm system and protective devices below:

- The pressure measurement device in compliance with ISO 80601-2-13
- The pressure restriction device in compliance with ISO 80601-2-13
- The expiratory volume monitor in compliance with ISO 80601-2-13
- The breathing system with alarm system in compliance with ISO 80601-2-13
- The anesthetic ventilation system in compliance with ISO 80601-2-13
- The AGSS transfer and receiving system in compliance with ISO 80601-2-13
- The anesthetic gas delivery device in compliance with ISO 80601-2-13
- The anesthetic ventilator in compliance with ISO 80601-2-13
- The O<sub>2</sub> monitor in compliance with ISO 80601-2-55
- The CO<sub>2</sub> monitor in compliance with ISO 80601-2-55
- The AG monitor in compliance with ISO 80601-2-55

The anesthesia machine is integrated with the pressure restriction device, expiratory volume monitor, breathing system with alarm system, pressure measurement device, anesthetic ventilation system, AGSS transfer and receiving system, anesthetic gas delivery device, anesthetic ventilator, O<sub>2</sub> monitor, CO<sub>2</sub> monitor and AG monitor in compliance with the aforementioned standards, where:

- The pressure restriction device, expiratory volume monitor and breathing system with alarm system also comply with ISO 80601-2-13.
- The O<sub>2</sub> monitor, CO<sub>2</sub> monitor, and AG monitor also comply with ISO 80601-2-13.

## B.1 Safety Specifications

Type of protection against electric shock	Class I equipment with internal electrical power supply. Where the integrity of the external protective earth (ground) in the installation or its conductors is in doubt, the equipment shall be operated from its internal electrical power supply (batteries).
Degree of protection against electric shock	BF, defibrillation-proof
Operating mode	Continuous
Degree of protection against hazards of explosion	Ordinary equipment, without protection against hazards of explosion, not for use with flammable anesthetics.
Degree of protection against harmful ingress of water	Protection against vertically falling water drops --IPX1
Electrical connections between the equipment and the patient	Non-electrical connections
Degree of Mobility	Mobile: including the base and casters of the anesthesia system
Disinfection methods	Steam autoclave, or can be disinfected

## B.2 Environmental Specifications

<b>Main Unit</b>			
<b>Item</b>	<b>Temperature (°C)</b>	<b>Related humidity (non-condensing)</b>	<b>Barometric pressure (kPa)</b>
Operating	10 to 40	15 to 95 %	70 to 106
Transport storage	-20 to +60 (O <sub>2</sub> sensor: -20 to +50)	10 to 95 %	50 to 106 (AG module: 70 to 106)

## B.3 Power Requirements

External AC power supply			
Input voltage	100 to 240 V	100 to 120 V	220 to 240 V
Input current	7A	7 A	6 A
Input frequency	50/60 Hz		
Leakage current	< 500 $\mu$ A		
Auxiliary output supply			
Output voltage	100 to 240 V	100 to 120 V	
Output frequency	50/60 Hz	50/60 Hz	
Output current(outlet 1)	3 A	3 A	
Output current(outlet 2)	3 A	3 A	
Output current(outlet 3)	3 A	3 A	
Output current(outlet 4)	3 A	3 A	
Total current	5A MAX	5A MAX	
Fuse(outlet 1)	T3.15AH/250V	T3.15AH/250V	
Fuse(outlet 2)	T3.15AH/250V	T3.15AH/250V	
Fuse(outlet 3)	T3.15AH/250V	T3.15AH/250V	
Fuse(outlet 4, optional)	T3.15AH/250V	T3.15AH/250V	
Total fuse	T5AH/250V	T5AH/250V	
Internal battery			
Number of batteries	One or two		
Battery type	Lithium-ion battery		
Time to shutdown	5 min at least (powered by new fully-charged batteries after the first low-power alarm)		
Operating time	90 min in case of one battery or 240 min in case of two batteries (powered by new fully-charged batteries at 25°C ambient temperature)		
AC input power line			
Length	5 m		

## B.4 Physical Specifications

<b>Anesthesia Machine</b>	
Size	1410mm × 780mm × 690mm (height × width × depth) (not including breathing system, including two vaporizers) 1410mm × 945mm × 690mm (height × width × depth) (including breathing system and two vaporizers)
Weight	<145 kg (without vaporizers and cylinders)
<b>Top Shelf</b>	
Weight limit	30 kg
Size	630mm × 315mm (width × depth)
<b>Worktable</b>	
Size	850 mm × 545 mm × 310 mm (height × width × depth)
<b>Drawer</b>	
Drawer	130 mm × 415 mm × 325 mm (height × width × depth)
<b>Caster</b>	
Caster	Four casters whose diameter is 125 mm. All four casters with brakes.
<b>Display</b>	
Type	Touchscreen
Size	10.4"
Resolution	1024 × 768 pixels
Brightness	Adjustable
<b>LED Indication</b>	
Alarm lamp	One (yellow and red. When high and medium level alarms occur simultaneously, it flashes red only). The visual alarm indication complies with the requirements of IEC 60601-1-8.
AC power LED	One (green; lit when connected to the AC power source).
Battery LED	One (green; lit when batteries are charged; extinguished when powered by batteries or no battery.)



<b>Audio Indication</b>	
Speaker/ Buzzer	One speaker or one buzzer. Gives off alarm tones and key tones; supports multi-level tone modulation. The alarm tones comply with the requirements of IEC 60601-1-8.
<b>Connector</b>	
Power supply	One AC mains inlet. Four auxiliary electrical outlets.
Network	One RJ45 connector to support network connection and online software upgrade.
Calibration Port	One DB9 female connector to support calibrating flow and pressure, power the calibration fixture and act as serial communication port with external devices.
RS-232 Communications Port	One DB9 male connector to act as serial communication port with external devices.
USB Ports	Two USB ports to support import configuration information and import/export configuration and history data.
Equipotential stud / lug	One

## B.5 Pneumatic Circuit System Specifications

<b>ACGO</b>		
Outlet	Coaxial 22 mm/15 mm conical connector	
<b>Gas Supplies</b>		
Pipeline pressure range	280 to 600 kPa	
Pipeline flow range	V <sub>max</sub> 120 L/min	
Pipeline inlet	DISS	
Cylinder pressure range	6.9 MPa ~ 20.0 MPa (O <sub>2</sub> /Air) 4.2 MPa ~ 6.0 MPa (N <sub>2</sub> O)	
Cylinder flow range	V <sub>max</sub> 120 L/min	
Cylinder inlet	PISS	
Backup oxygen supply pressure range	280 to 600 kPa	
Backup oxygen supply flow range	V <sub>max</sub> 120 L/min	
Backup oxygen supply inlet	NIST	
<b>O<sub>2</sub> Control</b>		
O <sub>2</sub> supply failure alarm	≤220.6 kPa ± 34.2kPa	
O <sub>2</sub> flush	25 to 75 L/min	
<b>Flowmeter</b>		
Flowmeters	Air range	0 to 15 L/min
	O <sub>2</sub> range	0 to 15 L/min
	N <sub>2</sub> O range	0 to 10 L/min
	Accuracy	Between -10% and +10% of the indicated value (under 20°C and 101.3 kPa, for flow between 10% and 100% of full scale)
Auxiliary O <sub>2</sub> supply	Gas supply	O <sub>2</sub> in the system
	Flow	0 to 15 L/min
	Accuracy	±0.25 L/min or ±10% of the indicated value, whichever is greater
<b>O<sub>2</sub>-N<sub>2</sub>O Link System</b>		
Type	Mechanical proportion control device	

Range	O <sub>2</sub> concentration not lower than 25%
<b>O<sub>2</sub>-N<sub>2</sub>O Cutoff Device</b>	
O <sub>2</sub> -N <sub>2</sub> O cutoff device	The O <sub>2</sub> supply pressure shall be less than 100 kPa when N <sub>2</sub> O supply is cut off.
<b>Gas Hose</b>	
Max pressure	1.4 MPa at 21 °C

## B.6 Breathing System Specifications

<b>System Leakage &amp; System Compliance &amp; System Volume</b>			
System leakage		≤ 75 mL/min at 3 kPa	
System compliance		Manual mode	≤4 mL/hPa (87~105ml@30hPa)
		Mechanical mode	Automatic compliance compensation (compensates for the loss of volume caused by CO <sub>2</sub> absorbent canister assembly and bellows assembly)
System volume	Without Pre-Pak	Manual mode: 1800 mL	Mechanical mode: 2600 mL
		Absorber canister: 1500 mL	
	With Pre-Pak	Manual mode: 1800 mL	Mechanical mode: 2850 mL
		Absorber canister: 1500 mL	
<b>Water Collection Cup</b>			
Type		Can be disassembled independently	
Volume		Approximately 6 mL	
<b>Interface and Connector</b>			
Expiration end		Coaxial 22 mm/15 mm conical connector	
Inspiration end		Coaxial 22 mm/15 mm conical connector	
Bag end		Coaxial 22 mm/15 mm conical connector	
Exhaust port		30 mm conical outlet	
<b>Airway pressure gauge</b>			
Range		-20 to +100 cmH <sub>2</sub> O	
Accuracy:		± (2% of the full scale reading + 4% of the actual reading)	
<b>APL valve</b>			
Range		1 to 75 cmH <sub>2</sub> O	
Tactility indication		Above 30 cmH <sub>2</sub> O	
Accuracy		±10 cmH <sub>2</sub> O or ±15% of the set value, whichever is greater	

**Pressure flow data (APL valve completely open)**

Flow (L/min)	APL pressure (cmH <sub>2</sub> O, dry)	APL pressure (cmH <sub>2</sub> O, moist)
3	0.22	0.22
10	0.27	0.28
20	0.32	0.33
30	0.39	0.39
40	0.49	0.50
50	0.61	0.62
60	0.78	0.80
70	0.94	0.96

**Minimum pressure to open the APL valve**

Dry	0.2 kPa
Moist	0.2 kPa

**Expiratory resistance\***

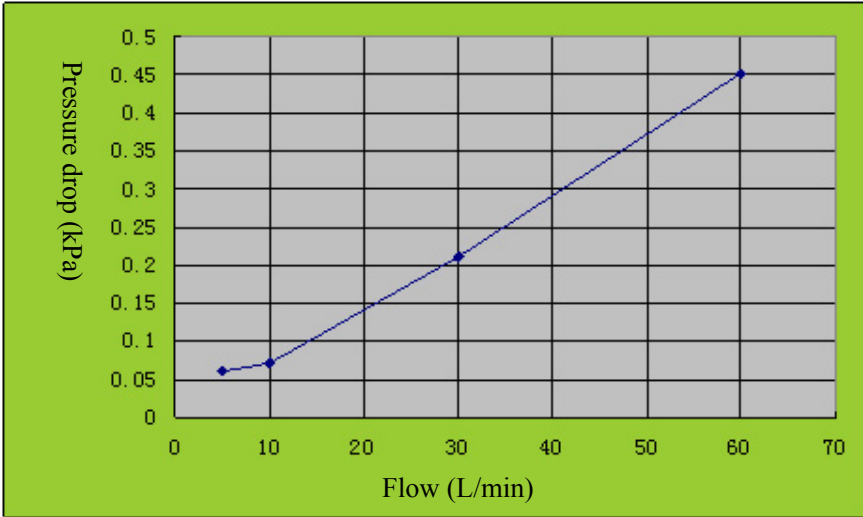

### Inspiratory resistance\*

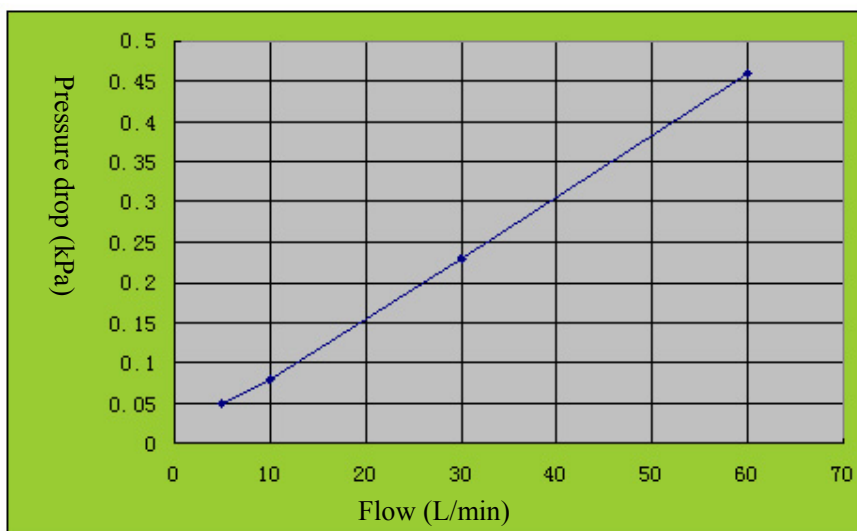

\* Adopt Medisorb™ absorbent to test breathing system flow resistance and compliance.

## B.7 Ventilator Specifications

Ventilator parameters		
Parameter	Range	Step
Plimit	10 to 100 cmH <sub>2</sub> O	1 cmH <sub>2</sub> O
Pinsp	5 to 60 cmH <sub>2</sub> O	1 cmH <sub>2</sub> O
Δ Psupp	3 to 60 cmH <sub>2</sub> O	1 cmH <sub>2</sub> O
PEEP	OFF, 3 to 30 cmH <sub>2</sub> O	1 cmH <sub>2</sub> O
Vt	For PCV-VG and SIMV-VG modes: 5mL to 1500mL; Other modes: 20 to 1500 mL	For PCV-VG and SIMV-VG modes: 1 mL (5 to 20 mL) 5 mL (20 to 100 mL) 10 mL (100 to 300 mL) 25 mL (300 to 1500 mL) Other modes: 5 mL (20 to 100 mL) 10 mL (100 to 300 mL) 25 mL (300 to 1500 mL)
Min Rate	2 to 60 bpm	1 bpm
Tslope	0 to 2 s	0.1 s
Rate	4 to 100 bpm	1 bpm
I:E	4:1 to 1:8	0.5

Tpause		OFF, 5 to 60 % of Tinsp	5%
Apnea I:E		4:1 ~ 1:8	0.5
Trig Window		5 to 90 %	5%
Tinsp		0.2 to 5 s	0.1 s
Trigger	P-Trig	-20 cmH <sub>2</sub> O to -1 cmH <sub>2</sub> O	1 cmH <sub>2</sub> O
	F-Trig	0.5 to 15 L/min	0.5 L/min
Exp %		5 to 60 %	5%
ΔP apnea		3~60 cmH <sub>2</sub> O	1 cmH <sub>2</sub> O
<b>Ventilator performance</b>			
Drive pressure		280 to 600 kPa	
Peak flow of inspiration valve		≥120 L/min	
Maximum MV		≥18 L/min	
<b>Ventilator monitored parameters</b>			
MV		0 to 100 L/min	
Vt		0 to 2500 mL	
Vt (PCV)		5 mL ~ 1500 mL	
Paw		-20 to 120 cmH <sub>2</sub> O	
Rate		0 to 120 bpm	
I:E		8:1 to 1:10	
Raw		0 to 600 cmH <sub>2</sub> O / (L/s)	
Compl		0 to 300 mL/ cmH <sub>2</sub> O	
PEEP		0 to 70 cmH <sub>2</sub> O	
O <sub>2</sub> concentration		18 % to 100 %	

## B.8 Ventilator Accuracy

Control accuracy	
Vt	<75 mL: $\pm 15$ mL; $\geq 75$ mL: $\pm 15$ mL or $\pm 10$ % of the set value, whichever is greater.
P <sub>insp</sub>	$\pm 3.0$ cmH <sub>2</sub> O or $\pm 8$ % of the set value, whichever is greater.
$\Delta$ P <sub>supp</sub>	$\pm 3.0$ cmH <sub>2</sub> O or $\pm 8$ % of the set value, whichever is greater.
$\Delta$ P <sub>apnea</sub>	$\pm 3.0$ cmH <sub>2</sub> O or $\pm 8$ % of the set value, whichever is greater.
P <sub>limit</sub>	$\pm 3.0$ cmH <sub>2</sub> O or $\pm 8$ % of the set value, whichever is greater.
PEEP	OFF: $\leq 4.0$ cmH <sub>2</sub> O; 3 to 30 cmH <sub>2</sub> O: $\pm 2.0$ cmH <sub>2</sub> O, or $\pm 8$ % of the set value, whichever is greater
Rate	$\pm 1$ bpm or $\pm 5$ % of the set value, whichever is greater.
Min Rate	$\pm 1$ bpm or $\pm 5$ % of the set value, whichever is greater.
I:E	2:1 to 1:4: $\pm 10$ % of the set value; Other range: $\pm 25$ % of the set value.
Apnea I:E	2:1 to 1:4: $\pm 10$ % of the set value; Other range: $\pm 25$ % of the set value.
T <sub>pause</sub>	20% to 60%: $\pm 15$ % of the set value; Other range: $\pm 25$ % of the set value.
T <sub>insp</sub>	$\pm 0.2$ s
Monitoring accuracy	
Vt	<75 mL: $\pm 15$ mL; $\geq 75$ mL: $\pm 15$ mL or $\pm 10$ % of the displayed value, whichever is greater.
P <sub>aw</sub>	$\pm 2.0$ cmH <sub>2</sub> O
PEEP	$\pm 2.0$ cmH <sub>2</sub> O or $\pm 10$ % of the displayed value, whichever is greater
Rate	$\pm 1$ bpm or $\pm 5$ % of the displayed value, whichever is greater.
I:E	2:1 to 1:4: $\pm 10$ % of the displayed value; Other range: $\pm 25$ % of the displayed value.
MV	$\pm 15$ % of the displayed value.
Raw	0 to 20 cmH <sub>2</sub> O/(L/s): $\pm 10$ cmH <sub>2</sub> O/(L/s); 20 to 600 cmH <sub>2</sub> O/ (L/s): $\pm 50$ % of the displayed value.
Compl	$\pm (10$ mL/ cmH <sub>2</sub> O or $+20$ % of the displayed value)
O <sub>2</sub> concentration	$\pm (2.5$ % of volume percentage + $2.5$ % of gas concentration)

<b>Alarm settings</b>			
<b>Parameter</b>		<b>Setting range</b>	<b>Remark</b>
FiO <sub>2</sub>	High Limit	OFF, 20 to 100 %	The specified high limit shall be 2% greater than the low limit.
	Low Limit	18 to 98 %	
V <sub>t</sub>	High Limit	5 to 1600 mL	The specified high limit shall be 5 mL greater than the low limit.
	Low Limit	0 to 1595 mL	
MV	High Limit	0.2 to 100 L/min	When the alarm setting range is 0 to 15 L/min, the specified high limit shall be 0.2 L/min greater than the low limit.
	Low Limit	0 to 99 L/min	When the alarm setting range is 15 to 100 L/min, the specified high limit shall be 1 L/min greater than the low limit.
Rate	High Limit	4 to 100 bpm	The specified high limit shall be 2 bpm greater than the low limit.
	Low Limit	2 to 98 bpm	
Paw	High Limit	2 to 100 cmH <sub>2</sub> O	The specified high limit shall be 2 cmH <sub>2</sub> O greater than the low limit.
	Low Limit	0 to 98 cmH <sub>2</sub> O	



## B.9 Anesthetic Vaporizer

Anesthetic vaporizer (for details, refer to the vaporizer Instructions for Use)	
Type	Penlon Sigma Delta anesthetic vaporizers. Four types of vaporizers with anesthetic agents Halothane, Enflurane, Isoflurane, and Sevoflurane are available. Mindray V60 vaporizer. Four types of anesthetic agents are available, which are Halothane, Enflurane, Isofluane, and Sevoflurane.
Selectatec® vaporizer manifold	
Vaporizer position	Single or double vaporizer positions (optional)
Mounting mode	Selectatec®, with interlocking function (Selectatec® is registered trademark of Datex-Ohmeda Inc.)
Plug-in® vaporizer manifold (optional)	
Vaporizer position	Double vaporizer positions
Mounting mode	Plug-in ®, with interlocking function

## B.10 Breathing System Temperature Controller

In the range of  $10^{\circ} \text{C} \leq T_{\text{ambient}} \leq 20^{\circ} \text{C}$ , the temperature at the middle plate test point near the inspiratory check valve shall be a minimum  $\Delta T$  of  $11^{\circ} \text{C}$  above the ambient temperature.

In the range of  $20^{\circ} \text{C} \leq T_{\text{ambient}} \leq 40^{\circ} \text{C}$ , the temperature at the middle plate test point near the inspiratory check valve shall be a minimum of  $31^{\circ} \text{C}$ .

In the range of  $10^{\circ} \text{C} \leq T_{\text{ambient}} \leq 40^{\circ} \text{C}$ , the temperature at the Y-piece animal connection test point shall be a maximum absolute value of  $\Delta T$  of  $2^{\circ} \text{C}$  above the ambient temperature and the temperature at the Y-piece animal connection test point shall be a maximum of  $41^{\circ} \text{C}$ .

Under the single fault condition, the temperature at the Y-piece animal connection test point shall be a maximum of  $41^{\circ} \text{C}$ .

---

## B.11 AGSS Transfer and Receiving System

### Specifications

#### Active AGSS

AGSS transfer and receiving system	
Size	430 mm × 132 mm × 114 mm (height x width x depth)
Type of disposal system	High-flow disposal system
Pump rate	75 to 105 L/min

AGSS transfer and receiving system	
Size	430 mm × 132 mm × 114 mm (height x width x depth)
Type of disposal system	Low-flow disposal system
Pump rate	25 to 50 L/min

AGSS transfer hose assembly	
Length	0.3 m

AGSS active drain tube assembly	
Length	4 m

#### Passive AGSS

AGSS passive drain tube assembly	
Length	4.7 m

## B.12 Negative Pressure Suction Device Specifications

Venturi Negative Pressure Suction Device	
Gas source	Air, from system gas source
Pipeline pressure range	280 to 600 kPa
Pipeline inlet	DISS
Maximum vacuum	≥50 kPa at supply gas pressure of 280 kPa
Minimum Flow	20 L/min (pressure gauge max)
Accuracy	± 5 % of full range
Noise	Less than 60dB

## B.13 O<sub>2</sub> Sensor Specifications

<b>O<sub>2</sub> sensor</b>	
Range	18 % to 100 %
Accuracy	±(2.5 % of volume percentage + 2.5 % of concentration)
Response time (21 % air to 100 % O <sub>2</sub> )	< 20 s
Measurement accuracy drift	Meets accuracy requirements within 6 h
Operating temperature range	-20°C to +50°C
Temperature compensation	±2 % of fluctuation at 0-40°C
Pressure range	50 to 200 kPa
Related humidity	0 to 99 %
Linearity	Linear 0-100 % O <sub>2</sub>
Expected Operating Life	1.5 x 10 <sup>6</sup> % O <sub>2</sub> hours at 20°C 0.8 x 10 <sup>6</sup> % O <sub>2</sub> hours at 40°C
Service life	Not more than 13 months after unpacked (in compliance with the service conditions specified by the manufacturer)
<b>Effect of interfering gas</b>	
<b>Gas under test</b>	<b>Error (% O<sub>2</sub>)</b>
50% He/ 50% O <sub>2</sub>	<1 %
80% N <sub>2</sub> O/ 20% O <sub>2</sub>	1 to 1.5 %
4% Halothane/ 28.8% O <sub>2</sub> / 67.2% N <sub>2</sub> O	1.5 % to 2 %
5% Sevoflurane/ 28.5% O <sub>2</sub> / 66.5% N <sub>2</sub> O	1 to 1.5 %
5% Enflurane/ 28.5% O <sub>2</sub> / 66.5% N <sub>2</sub> O	1.2 to 1.8 %
5% Isoflurane/ 28.5% O <sub>2</sub> / 66.5% N <sub>2</sub> O	1.2 to 1.8 %
5% CO <sub>2</sub> / 28.5% O <sub>2</sub> / 66.5% N <sub>2</sub> O	<1%
<b>Theory of Operation</b>	
O <sub>2</sub> sensor can monitor the animal's FiO <sub>2</sub> . O <sub>2</sub> sensor is of the self-powered, diffusion limited, metal-air battery type comprising an anode, electrolyte, diffusion barrier and air cathode as shown below:	

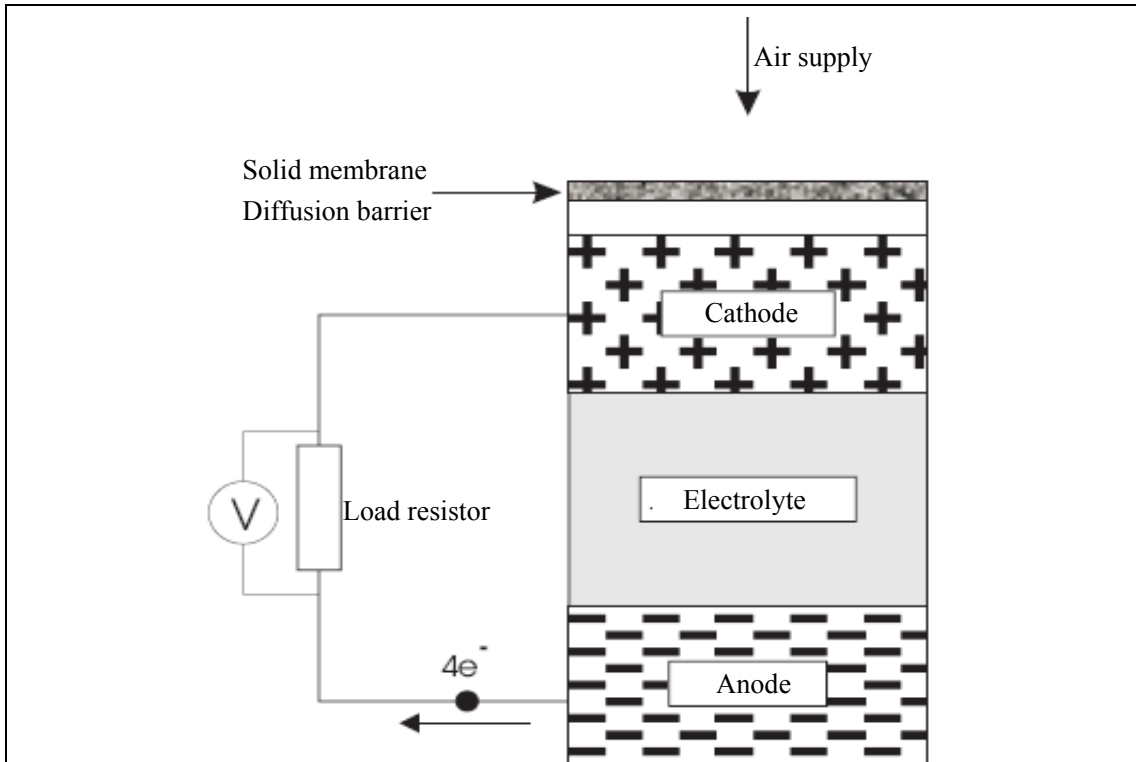

At the cathode oxygen is reduced to hydroxyl ions according to the equation:

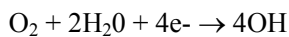

The hydroxyl ions in turn oxidize the metal anode as follows:



Overall the cell reaction may be represented as:

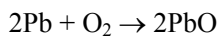

$\text{O}_2$  sensor is current generator, and the current is proportional to the rate of oxygen consumption (Faraday's Law). This current can be measured by connecting a resistor across the output terminals to produce a voltage signal. If the passage of oxygen into the sensor is purely diffusion limited, by the solid membrane diffusion barrier, then this signal is a measure of the oxygen partial pressure.

#### Signal Stability

$\text{O}_2$  sensor has highly stable outputs over their operating lives. Typical sensor drift rates are less than 1% per month when  $\text{O}_2$  sensor is exposed to gas in typical applications. Thus a sensor with a starting signal of 12 mV in 210 mBar oxygen will typically still be showing a signal greater than 10 mV as it approaches the end of its life.

#### Humidity Effects

Under conditions where liquid condensation may occur, care is needed to ensure the gas access holes do not become blocked. If liquids form in the region of the gas access hole, the flow of gas to the sensor will be restricted. With gas access restricted, a low signal will result. If a sensor shows signs of being affected by condensation, normal operation may be restored by drying the sensor with a soft tissue. Under no circumstances should these sensors be heated to dry them out. Changes in humidity levels which affect the  $\text{O}_2$  partial pressure will correspondingly alter the output signal of the sensor.

### Pressure Effects

Since the sensor measures O<sub>2</sub> partial pressure, the output will rise and fall due to pressure changes which affect the O<sub>2</sub> partial pressure. Thus an increase in pressure of 10 % at the sensor inlet will produce a 10 % increase in signal output. Nitrous oxide is highly soluble in neutral and alkaline solutions. Where the sensor is exposed to high levels of nitrous oxide, the solubility of this gas can in fact cause the internal pressure to increase to the point where the seals fail. O<sub>2</sub> sensor incorporates a patented pressure relief system in the rear of the sensor, limiting the internal pressure build up due to N<sub>2</sub>O dissolving in the electrolyte to a value well within the capacity of the sealing system. Test data shows that sensors are unaffected by months of operation in 100% N<sub>2</sub>O. Cross-interference tests with 10 % CO<sub>2</sub> (balance O<sub>2</sub>) show virtually no interference from CO<sub>2</sub>.

### Temperature Dependence

The rugged design of O<sub>2</sub> sensor means they are resistant to damage from extremes of high or low temperature. Even so, the sensor must never be exposed to temperatures at which the electrolyte will freeze (approx. -25°C), or temperatures which will harm the components of the sensor, i.e. the plastic or seals (>70°C). Sensor lifetime is governed by the mass of lead available to react with oxygen and its rate of consumption. High oxygen partial pressures and high temperatures will increase the sensor output current, thus shortening the operating life.

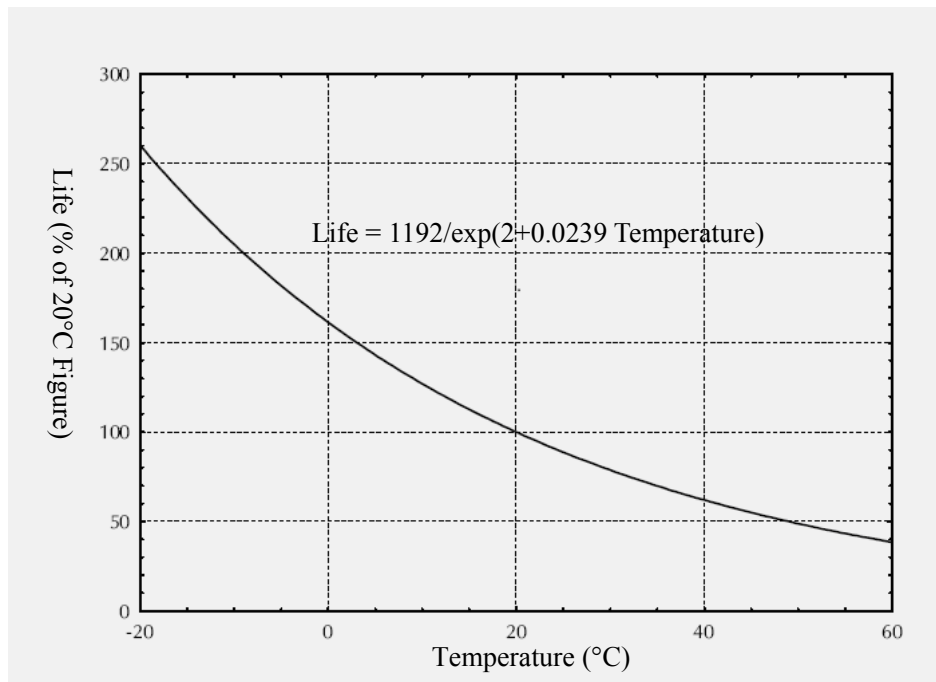

## B.14 CO<sub>2</sub> Module Specifications

### Mainstream CO<sub>2</sub> Module Specifications

Mainstream CO <sub>2</sub> module		
Type	single slot	
Range	0 mmHg to 150 mmHg	
Measurement range and accuracy	0 to 40 mmHg	±0.2% (±2 mmHg)
	41 to 70 mmHg	±5% of the reading
	71 to 100 mmHg	±8% of the reading
	101 to 150 mmHg	±10% of the reading
Resolution	1 mmHg	
Stability	Meets accuracy requirements within 6 h	
Rise time	<60 ms	
Response time	<2 s	
Rate	Range	0 bpm to 150 bpm
	Resolution	1 bpm
	Accuracy	±1 bpm
Mainstream CO <sub>2</sub> module alarm specifications		
CO <sub>2</sub> alarm limits	Range (mmHg)	Step (mmHg)
EtCO <sub>2</sub> High Limit	OFF, 2 to 150	1
EtCO <sub>2</sub> Low Limit	OFF, 0 to (high limit – 2)	
FiCO <sub>2</sub> High Limit	OFF, 1 to 150	

### Microstream CO<sub>2</sub> Module Specifications

Microstream CO <sub>2</sub> module		
Measurement mode	MiniMedi microstream CO <sub>2</sub> module: single slot	
Range	0 mmHg to 99 mmHg	
Measurement range and accuracy	0 to 38 mmHg	±2 mmHg
	39 to 99 mmHg	±(5 % of the reading + 0.08 % of (the reading minus 38))
Measurement accuracy drift	Meets accuracy requirements within 6 h	
Resolution	1 mmHg	
Pump rate	50 mL/min (accuracy: -7.5 mL/min to +15 mL/min)	

Initialization time	30 s (typical)	
Rise time	< 190 ms (10 to 90 %)	
Delay time	≤ 2.7 s	
System total response time	≤ 2.9 s (including rise time and delay time)	
Rate	Range	0 bpm ~ 150 bpm
	Resolution	1 bpm
	Accuracy	0 bpm ~ 70 bpm: ±1 bpm 71 bpm ~ 120 bpm: ±2 bpm 121 bpm ~ 150 bpm: ±3 bpm
<b>Microstream CO<sub>2</sub> module alarm specifications</b>		
<b>CO<sub>2</sub> alarm limits</b>	<b>Range (mmHg)</b>	<b>Step (mmHg)</b>
EtCO <sub>2</sub> High Limit	OFF, 2 to 99	1
EtCO <sub>2</sub> Low Limit	OFF, 0 to (high limit – 2)	
FiCO <sub>2</sub> High Limit	OFF, 1 to 99	

### Sidestream CO<sub>2</sub> Module Specifications

<b>Sidestream CO<sub>2</sub> module</b>		
Type	single slot or double slot	
Range	0 mmHg to 99 mmHg	
Measurement range and accuracy	0 to 40 mmHg	±2 mmHg
	41 to 76 mmHg (excluding 41 mmHg)	±5 % of the reading
	77 to 152 mmHg (excluding 77 mmHg)	±10 % of the reading
Resolution	1 mmHg	
Measurement accuracy drift	Meets accuracy requirements within 6 h	
Rate	Range	0 bpm to 120 bpm
	Resolution	1 bpm
	Accuracy	±2 bpm
Rise time	<330 ms@100 mL/min <300 ms@120 mL/min Measured by using neonatal watertrap and 2.5 m neonatal sampling line.	

	<300 ms@120 mL/min <240 ms@150 mL/min Measured by using adult watertrap and 2.5 m adult sampling line.	
Delay time	<4 s@100 mL/min <4 s@120 mL/min Measured by using neonatal watertrap and 2.5 m neonatal sampling line.	
	<5 s@120 mL/min <4.5 s@150 mL/min Measured by using adult watertrap and 2.5 m adult sampling line.	
System total response time	<4.5 s@100 mL/min <4.5 s@120 mL/min Measured by using neonatal watertrap and 2.5 m neonatal sampling line.	
	<5.5 s@120 mL/min <5 s@150 mL/min Measured by using adult watertrap and 2.5 m adult sampling line.	
Pump rate	Neonatal: 100 mL/min and 120 mL/min optional Adult/children: 120 mL/min and 150 mL/min optional	
Pump rate accuracy	±15% of the set value or ±15 mL/min, whichever is greater	
Warm-up time	<1 min, enter the ISO accuracy mode After 1 min, enters the full accuracy mode,	
Cleaning time of water trap <sup>2</sup>	neonatal	≥24h@100ml/min <sup>3</sup> ≥22h@110ml/min ≥20h@120ml/min
	adult/pediatric	≥19h@150ml/min ≥18h@180ml/min ≥17h@200ml/min
<b>Sidestream CO<sub>2</sub> alarm limits</b>	<b>Range</b>	<b>Step</b>
EtCO <sub>2</sub> High Limit	OFF, (low limit + 2) to 99 mmHg	1 mmHg
EtCO <sub>2</sub> Low Limit	OFF, 0 to (high limit – 2) mmHg	
FiCO <sub>2</sub> High Limit	OFF, 1 to 99 mmHg	

<sup>2</sup>Experiment condition: temperature of sampled gas is 37°C, ambient temperature is 23°C, relative humidity of sampled gas is 100%.

<sup>3</sup> Cleaning time of water trap ≥24h means that the liquid level will not exceed the MAX line within 24 hours.



Effect of interfering gas on CO <sub>2</sub> measured value		
Gas	Concentration (%)	Accuracy (% <sub>ABS</sub> )
N <sub>2</sub> O	≤60	0.1
Hal	≤4	
Sev	≤5	
Iso	≤5	
Enf	≤5	
*Additional error caused by gas interference when measured at 0 to 40 mmHg		

\*Typical accuracy measurement conditions are:

1. Measurement starts when the module warm-up state ends.
2. Ambient pressure: 750 to 760 mmHg; room temperature: 22 to 28°C.
3. The gas under test is dry gas and the balance gas is N<sub>2</sub>.
4. Pump rate: 100 mL/min; breath rate: not greater than 50 bpm; fluctuation of breath rate: less than ±3 bpm; I:E: 1:2.

Operating temperature (approximate to the module detector): 15 to 25°C or 50 to 55°C.

Measurement accuracy: ±4 mmHg (0 to 40 mmHg) or ±12% of the reading (41 to 99 mmHg) when the breath rate is greater than 50 bpm.

## B.15 AG Module Specifications

AG Module		
Type	Two-slot or three-slot module	
Measurement mode	Sidestream	
Warm-up time	ISO accuracy mode	<45 s
	Full accuracy mode	<10 min
Resolution	CO <sub>2</sub>	1 mmHg
Pump rate	Neonatal:	100/110/120 mL/min optional
	Adult:	150/180/200 mL/min optional
	Accuracy:	±10 mL/min or ±10%, whichever is greater
Range	CO <sub>2</sub>	0 to 10 %
	O <sub>2</sub> (optional)	0 to 100 %
	N <sub>2</sub> O	0 to 100 %
	Des	0 to 18 %
	Sev	0 to 8 %
	Enf, Iso, Hal	0 to 5 %

Accuracy (ISO accuracy mode)	CO <sub>2</sub>	±0.3%ABS		
	N <sub>2</sub> O	± (8%REL+2%ABS)		
	Other anesthetic agent	8%REL		
Accuracy (Full accuracy mode)	Gas	Range (%REL)	Accuracy (%ABS)	
	CO <sub>2</sub>	0 to 1	±0.1	
		1 to 5	±0.2	
		5 to 7	±0.3	
		7 to 10	±0.5	
	N <sub>2</sub> O	0 to 20	±2	
		20 to 100	±3	
	O <sub>2</sub>	0 to 25	±1	
		25 to 80	±2	
		80 to 100	±3	
	Des	0 to 1	±0.15	
		1 to 5	±0.2	
		5 to 10	±0.4	
		10 to 15	±0.6	
		15 to 18	±1	
	Sev	0 to 1	±0.15	
		1 to 5	±0.2	
		5 to 8	±0.4	
	Enf, Iso, Hal	0 to 1	±0.15	
		1 to 5	±0.2	
	Measurement accuracy drift	Meets accuracy requirements within 6 h		
	Update time	1 s		
	Rise time* (10% to 90%)	Gas	Measured by using DRYLINE™ adult/children watertrap and 2.5 m adult sampling line	Measured by using DRYLINE™ neonatal watertrap and 2.5 m neonatal sampling line
		CO <sub>2</sub>	≤250 ms@150 mL/min	≤250 ms@100 mL/min
≤250 ms@180 mL/min			≤250 ms@110 mL/min	
≤250 ms@200 mL/min			≤250 ms@120 mL/min	
N <sub>2</sub> O		≤250 ms@150 mL/min	≤250 ms@100 mL/min	
		≤250 ms@180 mL/min	≤250 ms@110 mL/min	
	≤250 ms@200 mL/min	≤250 ms@120 mL/min		

	O <sub>2</sub>	15% to 21%	≤500 ms@150 mL/min ≤500 ms@180 mL/min ≤500 ms@200 mL/min	≤600 ms@100 mL/min ≤600 ms@110 mL/min ≤600 ms@120 mL/min
		21% to 60%	≤700 ms@150 mL/min ≤700 ms@180 mL/min ≤700 ms@200 mL/min	≤800 ms@100 mL/min ≤800 ms@110 mL/min ≤800 ms@120 mL/min
	Enf		≤350 ms@150 mL/min ≤350 ms@180 mL/min ≤350 ms@200 mL/min	≤350 ms@100 mL/min ≤350 ms@110 mL/min ≤350 ms@120 mL/min
	Des, Sev, Iso, Hal		≤300 ms@150 mL/min ≤300 ms@180 mL/min ≤300 ms@200 mL/min	≤300 ms@100 mL/min ≤300 ms@110 mL/min ≤300 ms@120 mL/min
Delay time	<4 s			
System total response time	Gas		Measured by using DRYLINE™ adult/children watertrap and 2.5 m adult sampling line	Measured by using DRYLINE™ neonatal watertrap and 2.5 m neonatal sampling line
	CO <sub>2</sub>		<5 s@150 mL/min <5 s@180 mL/min <5 s@200 mL/min	<6s@100 mL/min <6s@110 mL/min <6s@120 mL/min
	N <sub>2</sub> O		<5 s@150 mL/min <5 s@180 mL/min <5 s@200 mL/min	<6s@100 mL/min <6s@110 mL/min <6s@120 mL/min
	O <sub>2</sub>		<5 s@150 mL/min <5 s@180 mL/min <5 s@200 mL/min	<6s@100 mL/min <6s@110 mL/min <6s@120 mL/min
	Hal, Iso, Enf, Sev, Des		<5 s@150 mL/min <5 s@180 mL/min <5 s@200 mL/min	<6s@100 mL/min <6s@110 mL/min <6s@120 mL/min
Rate	Range		2 bpm ~ 100 bpm	
	Resolution		1 bpm	
	Accuracy		2 bpm ~ 60 bpm: ±1 bpm 61 bpm ~ 100 bpm: ±2 bpm	
Cleaning time of water trap <sup>4</sup>	neonatal		≥24 h @100 mL/min <sup>5</sup> ≥22 h @110 mL/min	

<sup>4</sup> Experiment condition: temperature of sampled gas is 37°C, ambient temperature is 23°C, relative humidity of sampled gas is 100%.

<sup>5</sup> Cleaning time of water trap ≥24 h means that the liquid level will not exceed the MAX line within 24 h.

		≥20 h @120 mL/min
	adult/pediatric	≥19 h @150 mL/min ≥18 h @180 mL/min ≥17 h @200 ml/min
Primary agent ID threshold	Full accuracy mode	0.15 %
	ISO accuracy mode	0.4 %
Secondary agent ID threshold	primary agent ≤10%	Full accuracy mode: 0.3 % ISO accuracy mode: 0.5 %
	primary agent >10%	5% REL (10% REL for Isoflurane) of primary agent

AG alarm limits	Range	Step	Unit
EtCO <sub>2</sub> High Limit	OFF, (low limit + 2) to 99	1	mmHg
EtCO <sub>2</sub> Low Limit	OFF, 0 to (high limit - 2)		
FiCO <sub>2</sub> High Limit	OFF, 1 to 99		
EtN <sub>2</sub> O High Limit	OFF, (low limit + 2) to 100	1	%
EtN <sub>2</sub> O Low Limit	OFF, 0 to (high limit - 2)		
FiN <sub>2</sub> O High Limit	OFF, (low limit + 2) to 100		
FiN <sub>2</sub> O Low Limit	OFF, 0 to (high limit - 2)		
EtHal High Limit	OFF, (low limit + 0.2) to 5.0	0.1	%
EtHal Low Limit	OFF, 0.0 to (high limit - 0.2)		
FiHal High Limit	OFF, (low limit + 0.2) to 5.0		
FiHal Low Limit	OFF, 0.0 to (high limit - 0.2)		
EtEnf High Limit	OFF, (low limit + 0.2) to 5.0	0.1	%
EtEnf Low Limit	OFF, 0.0 to (high limit - 0.2)		
FiEnf High Limit	OFF, (low limit + 0.2) to 5.0		
FiEnf Low Limit	OFF, 0.0 to (high limit - 0.2)		
EtIso High Limit	OFF, (low limit + 0.2) to 5.0	0.1	%
EtIso Low Limit	OFF, 0.0 to (high limit - 0.2)		
FiIso High Limit	OFF, (low limit + 0.2) to 5.0		
FiIso Low Limit	OFF, 0.0 to (high limit - 0.2)		
EtSev High Limit	OFF, (low limit + 0.2) to 8.0	0.1	%
EtSev Low Limit	OFF, 0.0 to (high limit - 0.2)		
FiSev High Limit	OFF, (low limit + 0.2) to 8.0		
FiSev Low Limit	OFF, 0.0 to (high limit - 0.2)		
EtDes High Limit	OFF, (low limit + 0.2) to 18.0	0.1	%

EtDes Low Limit	OFF, 0.0 to (high limit – 0.2)		
FiDes High Limit	OFF, (low limit + 0.2) to 18.0		
FiDes Low Limit	OFF, 0.0 to (high limit – 0.2)		

Effect of interfering gas on AG measured value									
Gas	Concentration (%)	Quantitative effect (% <sub>ABS</sub> ) <sup>2)</sup>							
		CO <sub>2</sub>	N <sub>2</sub> O	Hal	Sev	Iso	Enf	Des	O <sub>2</sub>
CO <sub>2</sub>	≤10	/	0.1	0.1	0.1	0.1	0.1	0.1	0.1
N <sub>2</sub> O	≤60	0.1	/	0.1	0.1	0.1	0.1	0.1	0.1
Hal <sup>1)</sup>	≤4	0	0.1	/	0.1 <sup>3)</sup>	0.1 <sup>3)</sup>	0.1 <sup>3)</sup>	0.1	0.1
Sev <sup>1)</sup>	≤5	0	0.1	0.1 <sup>3)</sup>	/	0.1 <sup>3)</sup>	0.1 <sup>3)</sup>	0.1	0.1
Iso <sup>1)</sup>	≤5	0	0.1	0.1 <sup>3)</sup>	0.1 <sup>3)</sup>	/	0.1 <sup>3)</sup>	0.1	0.1
Enf <sup>1)</sup>	≤5	0	0.1	0.1 <sup>3)</sup>	0.1 <sup>3)</sup>	0.1 <sup>3)</sup>	/	0.1	0.1
Des <sup>1)</sup>	≤15	0	0.1	0.1 <sup>3)</sup>	0.1 <sup>3)</sup>	0.1 <sup>3)</sup>	0.1 <sup>3)</sup>	/	0.1
Xenon	<100%	0.1	0	0	0	0	0	0	0.5
Helium	<50%	0.1	0	0	0	0	0	0	0.5
Ethanol	<0.1%	0	0	0	0	0	0	0	0.5
Acetone	<1%	0.1	0.1	0	0	0	0	0	0.5
Methane	<1%	0.1	0.1	0	0	0	0	0	0.5

1) Multiple agent interference on CO<sub>2</sub>, N<sub>2</sub>O and O<sub>2</sub> is typically the same as single agent interference.

2) Maximum quantitative effect of each gas at concentrations within specified accuracy ranges for each gas. The total effect of all interferences shall not exceed 5% REL of gas concentration.

3) Applicable to AION 03 AG module only, equivalent to the interference of secondary AG to primary AG.

---

**FOR YOUR NOTES**

# C EMC

---

---

This equipment meets the requirements of IEC 60601-1-2: 2014.

The essential performance verified during the immunity testing comprised of Vt control accuracy, Vt monitoring accuracy, monitoring accuracy of the airway pressure, CO<sub>2</sub> accuracy and O<sub>2</sub> accuracy.

## NOTE

---

- **The anesthesia machine needs special precautions regarding EMC and needs to be installed and put into service according to the EMC information provided below.**
  - **Use of portable or mobile communications devices will degrade the performance of the equipment.**
  - **This equipment is intended for use in professional healthcare facility environment, If it is used in special environment, such as magnetic resonance imaging environment, the equipment may be disrupted by the operation of nearby equipment.**
- 

## **WARNING**

---

- **Use of accessories, transducers and cables other than those specified or provided by the manufacturer of this device could result in increased electromagnetic emissions or decreased electromagnetic immunity of this device and result in improper operation.**
  - **Use of this device adjacent to or stacked with other device should be avoided because it could result in improper operation. If such use is necessary, this device and the other device should be observed to verify that they are operating normally.**
  - **Portable RF communications equipment (including peripherals such as antenna cables and external antennas) should be used no closer than 30 cm (12 inches) to any part of the this device, including cables specified by the manufacturer. Otherwise, degradation of the performance of this device could result.**
  - **Other devices may interfere with this equipment even though they meet the requirements of CISPR.**
  - **When the input signal is below the minimum amplitude provided in technical specifications, erroneous measurements could result.**
- 
-

<b>Guidance and Declaration - Electromagnetic Emissions</b>		
This equipment is intended for use in the specified electromagnetic environment. The customer or the user of this equipment should assure that it is used in such an environment as described below.		
<b>Emissions test</b>	<b>Compliance</b>	<b>Electromagnetic environment-guidance</b>
Radio frequency (RF) emissions CISPR 11	Group 1	This equipment uses RF energy only for its internal function. Therefore, its RF emissions are very low and are not likely to cause any interference in nearby electronic equipment.
Radio frequency (RF) emissions CISPR 11	Class B	This equipment is suitable for use in all establishments, including domestic establishments and those directly connected to the public low-voltage power supply network that supplies buildings used for domestic purposes.
Harmonic emissions IEC 61000-3-2	Class A	
Voltage fluctuations/flicker emissions IEC 61000-3-3	Complies	



<b>Guidance and Declaration - Electromagnetic Immunity</b>			
This equipment is intended for use in the specified electromagnetic environment. The customer or the user of This equipment should assure that it is used in such an environment as described below.			
<b>Immunity test</b>	<b>IEC60601 test level</b>	<b>Compliance level</b>	<b>Electromagnetic environment - guidance</b>
Electrostatic discharge (ESD) IEC 61000-4-2	±8 kV contact ±15kV air	±8 kV contact ±15kV air	Floors should be wood, concrete or ceramic tile. If floors are covered with synthetic material, the relative humidity should be at least 30%.
Electrical fast transient/burst IEC 61000-4-4	±2 kV for power supply lines ±1 kV for input/output lines (length greater than 3 m)	±2 kV for power supply lines ±1 kV for input/output lines (length greater than 3 m)	Mains power quality should be that of a typical commercial or hospital environment.
Surge IEC 61000-4-5	±1 kV line(s) to line(s) ±2 kV line(s) to earth	±1 kV line(s) to line(s) ±2 kV line(s) to earth	
Voltage dips and Voltage interruptions IEC 61000-4-11	0 % $U_T$ for 0,5 cycle  0 % $U_T$ for 1 cycle and 70 % $U_T$ for 25/30 cycles  0 % $U_T$ for 250/300 cycle	0 % $U_T$ for 0,5 cycle  0 % $U_T$ for 1 cycle and 70 % $U_T$ for 25/30 cycles  0 % $U_T$ for 250/300 cycle	Mains power quality should be that of a typical commercial or hospital environment. If the user of our product requires continued operation during power mains interruptions, it is recommended that our product be powered from an uninterruptible power supply or a battery.
RATED power frequency magnetic fields IEC 61000-4-8	30 A/m	30 A/m	Power frequency magnetic fields should be at levels characteristic of a typical location in a typical commercial or hospital environment.
Note 1: $U_T$ is the AC mains voltage prior to application of the test level.			

### Guidance and Declaration - Electromagnetic Immunity

This equipment is suitable for use in the electromagnetic environment specified below. The customer or the user of the equipment should assure that it is used in such an environment.

Immunity test	IEC 60601 Test level	Compliance level	Electromagnetic environment - guidance
Conducted RF IEC 61000-4-6	3 Vrms 150k to 80 MHz	3 Vrms (V1)	Portable and mobile RF communications equipment should be used no closer to any part of the device, including cables, than the recommended separation distance calculated from the equation applicable to the frequency of the transmitter. Recommended separation distance:
	6 Vrms in ISM bands and amateur radio bands <sup>a</sup> between 0,15 MHz and 80 MHz	6 Vrms (V2)	
Radiated RF EM fields IEC 61000-4-3	3V/m (for RGM) 80 MHz to 2.7 GHz	3 V/m (E1)	$d = \left[ \frac{3.5}{V1} \right] \sqrt{P}$ 150kHz to 80 MHz  $d = \left[ \frac{3.5}{E1} \right] \sqrt{P}$ 80 MHz to 800 MHz
	10V/m(for anesthesia machine) 80 MHz to 2.7GHz	10 V/m	
Proximity fields from RF wireless communications equipment IEC61000-4-3	27 V/m 380 MHz to 390 MHz	27 V/m	$d = \left[ \frac{7}{E1} \right] \sqrt{P}$ 800 MHz to 2.7 GHz  where P is the maximum output power rating of the transmitter in watts (W) according to the transmitter manufacturer and d is the recommended separation distance in meters (m) <sup>b</sup> . Field strengths from fixed RF transmitters, as determined by an electromagnetic site survey <sup>c</sup> , should be less than the compliance level in each frequency range <sup>d</sup> Interference may occur in the vicinity of equipment marked with the following symbol: 
	28 V/m 430 MHz to 470 MHz, 800 MHz to 960 MHz, 1700 MHz to 1990 MHz, 2400 MHz to 2570 MHz	28 V/m	
	9 V/m 704 MHz to 787 MHz, 5100 MHz to 5800 MHz	9 V/m	

Note 1: At 80 MHz and 800 MHz, the higher frequency range applies.

Note 2: These guidelines may not apply in all situations. Electromagnetic propagation is affected by absorption and reflection from structures, objects and people.

- 
- a. The ISM (industrial, scientific, and medical) bands between 150 kHz and 80 MHz are 6.765 MHz to 6.795 MHz; 13.553 MHz to 13.567 MHz; 26.957 MHz to 27.283 MHz; and 40.66 MHz to 40.70 MHz. The amateur radio bands between 0.15 MHz and 80 MHz are 1.8 MHz to 2.0 MHz, 3.5 MHz to 4.0 MHz, 5.3 MHz to 5.4 MHz, 7 MHz to 7.3 MHz, 10.1 MHz to 10.15 MHz, 14 MHz to 14.2 MHz, 18.07 MHz to 18.17 MHz, 21.0 MHz to 21.4 MHz, 24.89 MHz to 24.99 MHz, 28.0 MHz to 29.7 MHz and 50.0 MHz to 54.0 MHz.
- b Compliance level in the ISM frequency bands between 150 kHz to 80 MHz and in the frequency range 80 MHz to 2.7 GHz are intended to decrease the likelihood that portable/ mobile communication equipment could cause interference if it is inadvertently brought into animal areas. For this reason, an additional factor of 10/3 is used in calculating the recommended separation distance for transmitters in these frequency ranges.
- c Field strengths from fixed transmitters, such as base stations for radio (cellular/cordless) telephones and land mobile radios, amateur radio, AM and FM radio broadcast and TV broadcast cannot be predicted theoretically with accuracy. To assess the electromagnetic environment due to fixed RF transmitters, an electromagnetic site survey should be considered. If the measured field strength in the location in which the device is used exceeds the applicable RF compliance level above, the device should be observed to verify normal operation. If abnormal performance is observed, additional measures may be necessary, such as reorienting or relocating the device.
- d Over the frequency ranges 150 kHz to 80 MHz, field strengths should be less than 3V/m.

<b>Recommended Separation Distances between Portable and Mobile RF, Communications Equipment and This Equipment</b>			
This equipment is intended for use in an electromagnetic environment in which radiated RF disturbance are controlled. The customer or the user of the equipment can help prevent electromagnetic interference by maintaining a minimum distance between portable and mobile RF communications equipment (transmitters) and the equipment as recommended below, according to the maximum output power of the communication equipment.			
<b>Rated Maximum Output power of Transmitter Watts (W)</b>	<b>Separation Distance According to Frequency of Transmitter (m)</b>		
	150 kHz to 80 MHz $d = \left[ \frac{3.5}{V1} \right] \sqrt{P}$	80 MHz to 800 MHz $d = \left[ \frac{3.5}{E1} \right] \sqrt{P}$	800 MHz to 2.7 GHz $d = \left[ \frac{7}{E1} \right] \sqrt{P}$
0.01	0.12	0.12	0.23
0.1	0.38	0.38	0.73
1	1.20	1.20	2.30
10	3.80	3.80	7.30
100	12.00	12.00	23.00
For transmitters at a maximum output power not listed above, the recommended separation distanced in meters (m) can be determined using the equation applicable to the frequency of the transmitter, where P is the maximum output power rating of the transmitter in watts (W) according to the transmitter manufacturer.			
Note 1: At 80 MHz and 800 MHz, the higher frequency range applies.			
Note 2: These guidelines may not apply in all situations. Electromagnetic propagation is affected by absorption and reflection from structures, objects and people.			

# D Alarm and Prompt Messages

---

---

This chapter lists physiological and technical alarm messages, and prompt message.

For each alarm message, corresponding actions are given instructing you to troubleshoot problems. If the problem persists, contact your service personnel.

## D.1 Physiological Alarm Messages

### NOTE

---

- The Disable in Manual and Cardiac Bypass mode column indicates how this alarm is controlled by the alarm on/off button and the cardiac bypass mode button in manual mode.
  - The Disable in Standby mode column indicates which physiological alarms will be disabled automatically in Standby mode.
- 

### D.1.1 VCM Physiological Alarm List

Message	Alarm Priority	Cause	Disabled when Alarm is off	Disabled in Standby mode
Apnea	Medium	Two triggering conditions are met simultaneously: 1. Paw < (PEEP+3) cmH <sub>2</sub> O for more than 20 s. 2. Vt < 10 mL for more than 20 s.	Yes	N/A
Volume Apnea >2 min	High	No breath has been detected within the last 120 s.	Yes	N/A
Paw Too High	High	Paw ≥ high alarm limit setting.	No	N/A
Paw Too Low	High	Paw ≤ low alarm limit setting for 20 s.	Yes	N/A
Pressure Limiting	Low	Paw ≥ Plimit.	N/A	N/A
FiO <sub>2</sub> Too High	Medium	FiO <sub>2</sub> > high alarm limit setting.	No	N/A
FiO <sub>2</sub> Too Low	High	FiO <sub>2</sub> < low alarm limit setting.	No	N/A
Vt Too High	Medium	Vt > high alarm limit setting.	Yes	N/A

Vt Too Low	Medium	Vt < low alarm limit setting.	Yes	N/A
MV Too High	Medium	MV > high alarm limit setting.	Yes	N/A
MV Too Low	Medium	MV < low alarm limit setting.	Yes	N/A
Rate Too High	Low	Rate > high alarm limit setting.	Yes	N/A
Rate Too Low	Low	Rate < low alarm limit setting.	Yes	N/A
Continuous Airway Pressure	High	Paw in the breathing circuit > sustained airway pressure alarm limit for 15 s.	No	N/A
Negative Pressure	High	Paw < -10 cmH <sub>2</sub> O for 1 second.	No	N/A

### D.1.2 AG Physiological Alarm List

Message	Alarm Priority	Cause	Disabled when Alarm is off	Disabled in Standby mode
EtCO <sub>2</sub> Too High	Medium	EtCO <sub>2</sub> > high alarm limit setting.	No	Yes
EtCO <sub>2</sub> Too Low	Medium	EtCO <sub>2</sub> < low alarm limit setting.	No	Yes
FiCO <sub>2</sub> Too High	Medium	FiCO <sub>2</sub> > high alarm limit setting.	No	Yes
EtN <sub>2</sub> O Too High	Medium	EtN <sub>2</sub> O > high alarm limit setting.	No	Yes
EtN <sub>2</sub> O Too Low	Medium	EtN <sub>2</sub> O < low alarm limit setting.	No	Yes
FiN <sub>2</sub> O Too Low	Medium	FiN <sub>2</sub> O > high alarm limit setting.	No	Yes
EtHal Too High	Medium	EtHAL > high alarm limit setting.	No	Yes
EtHal Too Low	Medium	EtHAL < low alarm limit setting.	No	Yes
FiHal Too High	Medium	FiHAL > high alarm limit setting.	No	Yes
FiHal Too Low	Medium	FiHAL < low alarm limit setting.	No	Yes
EtEnf Too High	Medium	EtENF > high alarm limit setting.	No	Yes
EtEnf Too Low	Medium	EtENF < low alarm limit setting.	No	Yes
FiEnf Too High	Medium	FiENF > high alarm limit setting.	No	Yes
FiEnf Too Low	Medium	FiENF < low alarm limit setting.	No	Yes
EtIso Too High	Medium	EtISO > high alarm limit setting.	No	Yes
EtIso Too Low	Medium	EtISO < low alarm limit setting.	No	Yes
FiIso Too High	Medium	FiIso > high alarm limit setting.	No	Yes
FiIso Too Low	Medium	FiIso < low alarm limit setting.	No	Yes
EtSev Too High	Medium	EtSev > high alarm limit setting.	No	Yes
EtSev Too Low	Medium	EtSev < low alarm limit setting.	No	Yes
FiSev Too High	Medium	FiSev > high alarm limit setting.	No	Yes

---

FiSev Too Low	Medium	FiSev < low alarm limit setting.	No	Yes
EtDes Too High	Medium	EtDes > high alarm limit setting.	No	Yes
EtDes Too Low	Medium	EtDes < low alarm limit setting.	No	Yes
FiDes Too High	Medium	FiDes > high alarm limit setting.	No	Yes
FiDes Too Low	Medium	FiDes < low alarm limit setting.	No	Yes
EtO <sub>2</sub> Too High	Medium	EtO <sub>2</sub> > high alarm limit setting.	No	Yes
EtO <sub>2</sub> Too Low	Medium	EtO <sub>2</sub> < low alarm limit setting.	No	Yes
FiO <sub>2</sub> Too High	Medium	FiO <sub>2</sub> > high alarm limit setting.	No	Yes
FiO <sub>2</sub> Too Low	Medium	FiO <sub>2</sub> < low alarm limit setting.	No	Yes
Apnea CO <sub>2</sub>	High	No breath is detected and Apnea time $\geq$ Apnea alarm time.	No	Yes

### D.1.3 CO<sub>2</sub> Physiological Alarm List

Message	Alarm Priority	Cause	Disable when Alarm is off	Disabled in Standby mode
EtCO <sub>2</sub> Too High	Medium	EtCO <sub>2</sub> > high alarm limit setting.	No	Yes
EtCO <sub>2</sub> Too Low	Medium	EtCO <sub>2</sub> < low alarm limit setting.	No	Yes
FiCO <sub>2</sub> Too High	Medium	FiCO <sub>2</sub> > high alarm limit setting.	No	Yes
Apnea CO <sub>2</sub>	High	No breath is detected and Apnea time $\geq$ Apnea alarm time.	No	Yes

## D.2 Technical Alarm Messages

### D.2.1 Startup Alarm List

#### NOTE

- Startup alarms will not trigger the alarm sound and alarm light.
- Startup alarms priority is only used to display in the alarm logbook.
- Startup Result if Fail column indicates the result when this startup phase alarm is triggered, which may be ALL, only manual, and Non- Functional.
- “All” indicates that all Automatic Ventilation, Manual Ventilation, and Cardiac Bypass modes are enabled.  
 “Manual Only” indicates that only Manual Ventilation and Cardiac Bypass modes are enabled.  
 “Non-Functional” indicates that the Anesthesia System cannot be used.

Message	Alarm Priority	Cause	Machine mode when checked	Startup result if fail	Remark
Bundle Version Error	High	Incompatible firmware version is installed.	Startup	Non-Functional	CPU Board
Bundle Version: Time out	High	Self-test result cannot be obtained due to an internal communication error.	Startup	Non-Functional	CPU Board
Aux Control Module Self Test Error	High	1. CPU, Flash or WTD error. 2. After power on, CPU board can't communicate with the Aux Control board.	Startup	Non-Functional	Aux Vent Control Board
Aux Control Module Self Test: Time out	High	Self-test result cannot be obtained due to an internal communication error.	Startup	Non-Functional	Aux Vent Control Board
Ventilator Self Test Error	High	1. CPU, TIMER, RAM, WTD, EEPROM or AD error 2. After power on, CPU board cannot communicate with the ventilator board.	Startup	Non-Functional	Ventilator Control Board
Ventilator Self Test: Time out	High	Self-test result cannot be obtained due to an internal communication error.	Startup	Non-Functional	Ventilator Control Board
Ventilator	High	5 V or 12 V voltage error.	Startup	Manual	Ventilator



Voltage Error				Only	Control Board
PEEP Valve Failure	Medium	1. PEEP valve voltage error. 2. PEEP valve pressure error.	Startup	Manual Only	Ventilator Control Board
Insp Valve Failure	Medium	1. Inspiratory valve voltage error. 2. Inspiratory valve flow error.	Startup	Manual Only	Ventilator Control Board
Safety Valve Failure	Medium	PEEP safety valve voltage error.	Startup	Manual Only	Ventilator Control Board
Flow Sensor Failure	Low	Ventilator flow is out of range.	Startup	Manual Only	Ventilator Control Board
Calibrate Flow Sensor and Insp Valve	Low	1. Calibration table isn't found in EEPROM. 2. Checksum of Calibration table does not match.	Startup	Manual Only	Ventilator Control Board
Calibrate Pressure Sensor and PEEP Valve	Low	1. Calibration table isn't found in EEPROM. 2. Checksum of Calibration table does not match.	Startup	Manual Only	Ventilator Control Board
Calibrate O <sub>2</sub> Sensor	Low	1. Calibration table isn't found in EEPROM. 2. Checksum of Calibration table does not match.	Startup	All	Ventilator Control Board
Ventilator Initialization Error	High	After power on, CPU board cannot send the parameter settings to the ventilator board.	Startup	Non-Functional	CPU Board
Ventilator Initialization: Time out	High	Self-test result cannot be obtained due to an internal communication error.	Startup	Non-Functional	CPU Board
Drive Gas Pressure Low	High	Drive Gas Pressure is low	Startup	All	Ventilator Control Board
Drive Gas Valve Self Test Error	Low	Drive Gas Valve Error	Startup	All	VPM Board
O <sub>2</sub> Supply Failure	High	O <sub>2</sub> Supply Failure.	Startup	All	Ventilator Control Board
Power Supply	High	3.3 V, 5 V, 12 V voltage error.	Startup	Manual	Power

Voltage Error				Only	Board
RT Clock Needs Battery	High	There is no button battery cell available in the system, or the button battery cell power is depleted.	Startup only	All	CPU Board
RT Clock Failure	High	RT chip malfunction.	Startup only	All	CPU Board
Keyboard Self Test Error	High	Keyboard Self Test Error.	Startup only	All	Keyboard
Keyboard Self Test: Time out	High	Keyboard Self Test result cannot be obtained due to communication error.	Startup only	Non-Functional	Keyboard
External AG Self Test Error	Low	If the module sends the ErrorMessage, except for data limit error and unspecified accuracy, "External AG Self Test Error" shall be triggered.	Startup only	All	AG Module
Internal AG Error 02	Low	If the module sends the ErrorMessage, except for data limit error and unspecified accuracy, "Internal AG Error 02" shall be triggered.	Startup only	All	AG Module
External AG: Time out	Low	External AG selftest result can not be obtained due to communication error.	Startup only	All	AG Module
Internal AG: Time out	Low	Internal AG selftest result can not be obtained due to communication error.	Startup only	All	AG Module
CO <sub>2</sub> Self Test Error	Low	CO <sub>2</sub> Self Test failure.	Startup only	All	CO <sub>2</sub> Module
CO <sub>2</sub> Self Test: Time out	Low	CO <sub>2</sub> Self Test result can not be obtained due to communication error.	Startup only	All	CO <sub>2</sub> Module

## D.2.2 CPU Board Runtime Alarm

Message	Alarm Priority	Cause	Machine mode when checked	Startup result if fail	Remark
IP Address Conflict	Medium	The IP address of the machine is the same as the IP address of another device in the local network.	Startup	Runtime	No
Fan Failure	Medium	Speed of the fan $\leq$ 20% of normal speed	Startup	Runtime	No
Fan Failure 02	Medium	Speed of Module Rack fan < 3640	Startup	Runtime	No

## D.2.3 Power Board Runtime Alarm

Message	Alarm Priority	Cause	Machine mode when checked	Startup result if fail	Remark
Power System Comm Stop	High	Lost communication with CPU board for 10 s.	Runtime	No	No
Power Supply Voltage Error	High	3.3 V, 5 V, 12 V voltage error.	Runtime	No	No
Low Battery Voltage!	High	Battery voltage is less than 10.6 V for 5 s.	Runtime	No	Yes
System going DOWN, Battery depleted!	High	Battery voltage is less than 10.2 V.	Runtime	No	Yes
Battery Undetected	Medium	Battery undetected.	Runtime	No	No
Battery in Use	Low	AC power fail.	Runtime	No	No
Power Board High Temp	High	Power board temperature is greater than 95 °C.	Runtime	No	No
Heating Module Failure	Low	1. Both resistance temperatures are greater than 105 °C or less than 0 °C for 20 s. 2. One of the resistance temperatures is greater than 110 °C for 15 s.	Runtime	No	No
Breathing Circuit Not Mounted	High	Breathing Circuit is not mounted.	Runtime	No	No

## D.2.4 Ventilator Control Board Runtime Alarm

Message	Alarm Priority	Cause	Machine mode when checked	Disabled in Standby mode
Aux Control Module Comm Stop	High	Lost communication with CPU board for 10 s.	Runtime	No
Ventilator Voltage Error	High	5 V or 12 V voltage error	Runtime	No
PEEP Valve Failure	Medium	1. PEEP valve voltage error. 2. PEEP valve pressure error.	Runtime	No
Insp Valve Failure	Medium	1. Inspiratory valve voltage error. 2. Inspiratory valve flow error.	Runtime	No
Safety Valve Failure	Medium	PEEP safety valve voltage error.	Runtime	No
Flow Sensor Failure	Low	1. Inspiratory flow is out of range. 2. Expiratory flow is out of range.	Runtime	No
Check Flow Sensors	High	1. Inspiratory reverse flow. 2. Expiratory reverse flow.	Runtime	N/A
Pinsp Not Achieved	Low	Pinsp does not reach the Pinsp setting in pressure mode.	Runtime	N/A
Vt Not Achieved	Low	Vt does not reach the Vt setting in volume mode.	Runtime	N/A
ACGO 3-way Valve Failure	Medium	ACGO 3-way Valve status is error.	Runtime	No
Automatic Ventilation Disabled	Low	Power on self test failed, and the result is "Manual Only".	Runtime	No
Auto Ventilation Disabled-Leak Test Failed	Low	Automatic Circuit Leak Test failed, and the result is "Manual Only".	Runtime	No
Auto Ventilation is Non-Functional	High	System is in the Auto Ventilation Non-functional state.	Runtime	N/A
Pressure Monitoring Channel Failure	Medium	For VPM: Monitored value of PEEP sensor or Paw sensor is out of range.	Runtime	No
Aux Control Module Voltage	Low	VPM 1.3 V voltage error.	Runtime	No
Pressure Monitoring Channel Failure	Medium	For VCM: 1. Monitored value of PEEP sensor or Paw	Runtime	No

		<p>sensor is out of range.</p> <p>2. Zero of PEEP sensor or Paw sensor is abnormal.</p> <p>3. PEEP sensor is reversely connected.</p>		
Patient Circuit Leak	Medium	<p>1. Vte is less than Vti to the maximum of 200 mL and 50% for 30 s.</p> <p>2. Vti is less than Vt delivery in volume mode.</p> <p>3. Animal is not connected.</p>	Runtime	N/A
CO <sub>2</sub> Absorber Canister Not Locked	High	CO <sub>2</sub> Canister is not mounted.	Runtime	No
O <sub>2</sub> Sensor Disconnected	Low	O <sub>2</sub> Sensor is not connected.	Runtime	No
Replace O <sub>2</sub> sensor	Low	The O <sub>2</sub> value is less than 5 %.	Runtime	No
Calibrate O <sub>2</sub> Sensor	Low	The O <sub>2</sub> value is greater than 110% or between 5% and 15% for 3 s.	Runtime	No
Ventilator Comm Stop	High	Lost communication with the CPU board for 10 s.	Runtime	No
Drive Gas Pressure Low	High	Drive Gas Pressure is low.	Runtime	No
O <sub>2</sub> Supply Failure	High	O <sub>2</sub> Supply Failure.	Runtime	No
Fresh Gas Flow Too High	Low	In VCV and SIMV-VC modes, the fresh gas flow is greater than or equal to the desired flow.	Runtime	N/A

## D.2.5 Key Board

Message	Alarm Priority	Cause	Machine mode when checked	Disabled in Standby mode
Key Error	Medium	The duration of hard key press exceeds 35 s.	Runtime	No
Keyboard Comm Stop	Medium	The communication with CPU board has stopped for 10 s.	Runtime	No

## D.2.6 AG Module Alarm List

External AG Module alarm list:

Message	Alarm Priority	Cause	Machine mode when checked	Disabled when external AG is in Standby mode
AG Hardware Error	Medium	AG module Hardware Error.	Runtime	Yes
O <sub>2</sub> Sensor Error	Medium	Paramagnetic O <sub>2</sub> sensor error.	Runtime	Yes
External AG Self Test Error	Low	Module fault or communication failure between the module and anesthesia system.	Runtime	Yes
AG Hardware Malfunction	High	AG module hardware malfunction. The AG module enters Standby and measurement stops.	Runtime	Yes
AG Init Error	High	The AG module was installed improperly or malfunctioned.	Runtime	Yes
AG No Watertrap	Low	The AG module watertrap was installed improperly or not installed.	Runtime	Yes
AG Watertrap Type Wrong	Low	When the animal type doesn't match the watertrap type, this alarm will be triggered.	Runtime	Yes
AG Change Watertrap	Medium	The AG watertrap was changed.	Runtime	Yes
AG Comm Stop	High	AG module malfunction or communication failure.	Runtime	No
AG Airway Occluded	High	Pump rate is lower than 20 mL/min for 1 s.	Runtime	Yes
AG Zero Failed	Low	Gas measurements may have bad accuracy during zeroing.	Runtime	Yes
Mixed Agent	Low	MAC < 3	Runtime	Yes
Mixed Agent	Medium	When there is an invalid MAC value and mixed agent at the same time, system shall trigger this alarm.	Runtime	Yes
Mixed Agent and MAC ≥ 3	Medium	MAC ≥ 3	Runtime	Yes
CO <sub>2</sub> Over Range	Low	The monitoring value exceeds the measurable range.	Runtime	Yes
N <sub>2</sub> O Over Range	Low		Runtime	Yes
HAL Over Range	Low		Runtime	Yes
ENF Over Range	Low		Runtime	Yes

---

ISO Over Range	Low		Runtime	Yes
SEV Over Range	Low		Runtime	Yes
O <sub>2</sub> Over Range	Low		Runtime	Yes
Rate Over Range	Low		The monitoring value of Rate (AG) exceeds the module accuracy	Runtime

Internal AG Module alarm list:

<b>Message</b>	<b>Alarm Priority</b>	<b>Cause</b>	<b>Machine mode when checked</b>	<b>Disabled when internal AG is in Standby mode</b>
Internal AG Error 01	Low	Internal AG Hardware Error	Runtime	Yes
Internal AG Error 02	Low	Internal AG Selftest Error.	Runtime	Yes
Internal AG Error 03	Low	Internal AG Hardware Malfunction	Runtime	Yes
Internal AG Error 04	Low	Internal AG Init Error	Runtime	Yes
Internal AG Error 05	Low	Internal AG Comm Stop	Runtime	Yes
Internal AG Error 07	Low	Internal AG Zero Failed	Runtime	Yes
Internal AG Error 09	Low	Internal AG No Watertrap	Runtime	Yes
Internal AG Error 10	Low	Internal AG Airway Occluded	Runtime	Yes
Internal AG Error 11	Low	Internal AG Change Watertrap	Runtime	Yes

## D.2.7 CO<sub>2</sub> Module Alarm Messages

Sidestream CO<sub>2</sub> module:

Message	Alarm Priority	Cause	Machine mode when checked	Disabled when CO <sub>2</sub> is in Standby mode
CO <sub>2</sub> Comm Stop	High	CO <sub>2</sub> module error or Comm error	Runtime	No
CO <sub>2</sub> Sensor High Temp	Low	CO <sub>2</sub> Sensor Temp too high (greater than 63 °C)	Runtime	Yes
CO <sub>2</sub> Sensor Low Temp	Low	CO <sub>2</sub> Sensor Temp too low (lower than 5 °C)	Runtime	Yes
CO <sub>2</sub> High Airway Press.	Low	Airway Press too high (greater than 790mmHg)	Runtime	Yes
CO <sub>2</sub> Low Airway Press.	Low	Airway Press too low (lower than 428mmHg)	Runtime	Yes
CO <sub>2</sub> High Barometric	Low	Barometric is greater than 790 mmHg	Runtime	Yes
CO <sub>2</sub> Low Barometric	Low	Barometric is lower than 790 mmHg	Runtime	Yes
CO <sub>2</sub> Hardware Error	High	1.External AD 2.5 V Error 2.12 V Voltage Error 3.Internal AD 2.5 V Error 4.Air pump Error 5.3-Way Valve Error	Runtime	Yes
CO <sub>2</sub> Sampleline Occluded	Low	Sampleline Occluded	Runtime	Yes
CO <sub>2</sub> System Error	Low	Multi-System error	Runtime	Yes
CO <sub>2</sub> No Watertrap	Low	CO <sub>2</sub> No Watertrap or Watertrap disconnected	Runtime	Yes
EtCO <sub>2</sub> Overrange	Low	The monitoring value exceeds the measurable range.	Runtime	Yes
FiCO <sub>2</sub> Overrange	Low		Runtime	Yes
CO <sub>2</sub> Zero Failed	Low	Mindray CO <sub>2</sub> module Error	Runtime	Yes
CO <sub>2</sub> Init Error	High	CO <sub>2</sub> Init Error	Runtime	Yes
Incompatible CO <sub>2</sub> Software Version	High	The CO <sub>2</sub> module detected is not compatible.	Runtime	No



Mainstream CO<sub>2</sub> module:

Message	Alarm Priority	Cause	Machine mode when checked	Disabled when CO <sub>2</sub> is in Standby mode
EtCO <sub>2</sub> Over range	Low	The monitoring value exceeds the measurable range.	Runtime	No
FiCO <sub>2</sub> Over range	Low		Runtime	Yes
CO <sub>2</sub> Zero Failed	Low	Mindray CO <sub>2</sub> module error.	Runtime	Yes
CO <sub>2</sub> Init Error	High	CO <sub>2</sub> Init Error.	Runtime	Yes
CO <sub>2</sub> Sensor Error	Low	Main CO <sub>2</sub> module sensor error.	Runtime	Yes
CO <sub>2</sub> No Sensor	Low	Main CO <sub>2</sub> module sensor is disconnected or Main CO <sub>2</sub> module sensor Comm error.	Runtime	Yes

Microstream CO<sub>2</sub> module:

Message	Alarm Priority	Cause	Machine mode when checked	Disabled when CO <sub>2</sub> is in Standby mode
CO <sub>2</sub> Comm Stop	High	CO <sub>2</sub> module error or Comm error	Runtime	No
CO <sub>2</sub> Sampleline Occluded	Low	Sampleline Occluded	Runtime	Yes
EtCO <sub>2</sub> Over range	Low	The monitoring value exceeds the measurable range.	Runtime	No
FiCO <sub>2</sub> Over range	Low		Runtime	Yes
CO <sub>2</sub> Check Airway	Low	MiniMedi CO <sub>2</sub> module Error	Runtime	Yes
CO <sub>2</sub> No Sampleline	Low	MiniMedi CO <sub>2</sub> sampleline disconnected	Runtime	Yes
CO <sub>2</sub> Main Board Error	High	MiniMedi CO <sub>2</sub> module Error	Runtime	Yes
CO <sub>2</sub> Check Sensor or Main Board	Low	MiniMedi CO <sub>2</sub> module Error	Runtime	Yes
CO <sub>2</sub> Replace Scrubber&Pump	Low	MiniMedi CO <sub>2</sub> module Error	Runtime	Yes
CO <sub>2</sub> Replace Sensor	Low	MiniMedi CO <sub>2</sub> module Error	Runtime	Yes
CO <sub>2</sub> 15V Overrange	High	MiniMedi CO <sub>2</sub> module Error	Runtime	Yes
CO <sub>2</sub> Init Error	High	CO <sub>2</sub> Init Error	Runtime	Yes
CO <sub>2</sub> Temp Overrange	Low	CO <sub>2</sub> Temperature Overrange	Runtime	Yes
CO <sub>2</sub> Overrange	Low	MiniMedi CO <sub>2</sub> module Overrange	Runtime	Yes
CO <sub>2</sub> Check Cal.	Low	MiniMedi CO <sub>2</sub> module Error	Runtime	Yes

---

## D.3 Prompt Messages

### D.3.1 Prompt Messages Displayed in Alarm Area

Message	Remark
Volume and Apnea Alarms are OFF	This message appears when the current mode is not Auto mode and [Alarms] button in the [Manual] mode tab is set to OFF.
CO <sub>2</sub> and CO <sub>2</sub> Apnea Alarms are OFF	This message appears when the current mode is not Auto mode and the [CO <sub>2</sub> Alarms] button in the [Manual] mode tab is set to OFF.
Load Configuration Failure	This message appears when load user or latest configuration failed.
DEMO Mode - Not for Clinical Use	This message appears when the system is set to Demo mode from the [Service] tab.
Service Mode - Not for Clinical Use	This message appears when the machine is worked in Service mode.
Apnea Ventilation	This message will appear when the Mini Rate is triggered in PS mode.
Calibrate O <sub>2</sub> sensor for 21%	If more than 72 h have elapsed since the last successful calibration, the prompt message "Calibrate O <sub>2</sub> sensor for 21%" is displayed.
Calibrate O <sub>2</sub> sensor for 100%	This message appears when the 100% calibration data couldn't be revised correctly after 21% O <sub>2</sub> sensor calibrate successfully.
Auto-zero in process	This message appears when auto-zeroing of the pressure sensors is in process.
New functions activated, please restart!	This message appears when function activation is completed successfully.
Restart to Activate New Flowmeter Standard	This message appears when flowmeter standard is changed
Could not locate time server	This message appears when the Interval of SNTP Protocol is not Off and the time server is unavailable for 5 intervals.
Drive Gas Switch to AIR	This message appears when the set drive gas is O <sub>2</sub> , and then drive gas switch to Air.
Drive Gas Switch to O <sub>2</sub>	This message appears when the set drive gas is Air, and then drive gas switch to O <sub>2</sub> .
Drive Gas Switched Back to O <sub>2</sub>	This message appears when the drive gas is turned back to O <sub>2</sub> supply.
Drive Gas Switched Back to AIR	This message appears when the drive gas is turned back to Air supply.
External AG Loaded Successfully	External AG Loaded Successfully.
External AG Unloaded Successfully	External AG Unloaded Successfully.

External AG Startup	External AG module is starting up.
External AG Warmup	External AG module is warming up.
External AG Zeroing	The external AG module is being zeroed.
CO <sub>2</sub> Warmup	CO <sub>2</sub> module is working in warmup status.
CO <sub>2</sub> Startup	CO <sub>2</sub> module is starting up.
CO <sub>2</sub> Zero Running	CO <sub>2</sub> Zero is Running.
CO <sub>2</sub> Loaded Successfully	CO <sub>2</sub> module is loaded successfully.
CO <sub>2</sub> Unloaded Successfully	CO <sub>2</sub> module is unloaded successfully.
CO <sub>2</sub> Purging	MiniMedi CO <sub>2</sub> module, detected Sampleline Occluded, shall start purging.
CO <sub>2</sub> in Self-Maintenance	CO <sub>2</sub> module is in Self-Maintenance status.
CO <sub>2</sub> Sensor Warmup	Capnostat CO <sub>2</sub> module is in warmup status.
CO <sub>2</sub> Zero Required	CO <sub>2</sub> Zero is required.
CO <sub>2</sub> Check Adapter	Capnostat CO <sub>2</sub> module adapter error.

### D.3.2 Prompt Messages Displayed in Pop-up Area

Message	Remark
Out of Range	This message appears when entered value is outside the allowable range.
Invalid Password	This message appears when entered password is wrong.
Saving User Configuration has failed.	This message appears when the [ <b>Saving User Configuration</b> ] process has failed.
New password input is inconsistent.	This message appears when the new password and the confirmed new password do not match.
Fresh gas flow detected! Adjust all flowmeters to zero	This message appears in the first "Manual Circuit Leak Test" or "Automatic Circuit Leak Test & Compliance Test" or Standby screen when fresh gas flow is detected.
Access to System settings only available in Standby	This message appears when the current mode is in non-standby and the user tries to enter the  key → [ <b>System</b> ] tab.
Set Auto/Manual switch to Manual position and adjust all flowmeters to zero	This message appears in the first "Manual Circuit Leak Test" screen when pressing the disabled [ <b>Continue</b> ] button.
Set Auto/Manual switch to Auto position and adjust all flowmeters to zero	This message appears in the first "Automatic Circuit Leak Test & Compliance Test" or Standby screen when pressing the disabled [ <b>Continue</b> ] button.
Invalid Age! Please check DOB or current system time.	This message appears when input DOB is valid but the animal calculation age is bigger than 150 or smaller than 0 years.
Warning: Do not remove USB	This message appears when the defaults are exporting / importing via USB

---

mass storage device until data transfer has completed!	mass storage device.
The event cannot be found in the Event Log!	This message appears when the event bubble is clicked in the [ <b>Graphic Trends</b> ] tab, but the corresponding event log entry is not found.

# E Symbols and Abbreviations

---

---

## E.1 Symbols

Symbol	Description
-	Minus
%	Percent
/	per; divide; or
~	To
^	Power
+	Plus
=	equal to
<	less than
>	greater than
≤	less than or equal to
≥	greater than or equal to
±	plus or minus
×	Multiply
©	Copyright
≈	approximately
™	trademark
®	registered trademark

## E.2 Units of Measure

Unit of measure	Description
A	ampere
Ah	ampere hour
bpm	breaths per minute
°C	degree Celsius
Cc	cubic centimeter
Cm	centimeter
cmH <sub>2</sub> O	centimeter of water

---

dB	decibel
°F	Fahrenheit
g	gram
h	hour
Hz	hertz
hPa	hectopascal
Inch	inch
k	kilo
kg	kilogram
kPa	kilopascal
L	litre
Lb	pound
nm	nanometer
m	meter
mAh	microampere hour
mbar	millibar
mg	milligrams
min	minute
mL	milliliter
mm	millimeters
mmHg	millimeters of mercury
ms	millisecond
mV	millivolt
mW	milliwatt
ppm	part per million
s	second
V	volt
VA	volt ampere
Ω	ohm
μA	microampere
μV	microvolt
W	watt

---

## E.3 Abbreviations

Abbreviation	Description
AA	Anaesthetic Agent
AG	anesthetic Gas
AGSS	Anesthesia Gas Scavenging System
ACGO	Auxiliary Common Gas Outlet
APL	airway Pressure Limit
BTPS	Body Temperature and Pressure, Saturated
Compl	Compliance (Cdyn)
CO <sub>2</sub>	Carbon Dioxide
Enf	Enflurane
Et	End-tidal
EtAA	End-tidal Anesthetic Agent
EtCO <sub>2</sub>	End-tidal Carbon Dioxide
EtENF	End-tidal Enflurane Concentration at Expiration
EtHAL	End-tidal Halothane Concentration at Expiration
EtISO	End-tidal Isoflurane Concentration at Expiration
EtN <sub>2</sub> O	End-tidal Nitrous Oxide concentration at Expiration
EtO <sub>2</sub>	End-tidal Oxygen Concentration at Expiration
EtSEV	End-tidal Sevoflurane Concentration at Expiration
F <sub>insp</sub>	Flow of Inspiration
F <sub>i</sub>	Fractional Concentration
F <sub>i</sub> AA	Fractional Concentration of Anesthetic Agent in Inspired Gas
F <sub>i</sub> CO <sub>2</sub>	Fraction of Inspired Carbon Dioxide
F <sub>i</sub> ENF	Fractional Concentration of Enflurane in Inspired Gas
F <sub>i</sub> HAL	Fractional Concentration of Halothane in Inspired Gas
F <sub>i</sub> ISO	Fractional Concentration of Isoflurane in Inspired Gas
F <sub>i</sub> O <sub>2</sub>	Fractional Concentration of O <sub>2</sub> in Inspired Gas
F <sub>i</sub> SEV	Fractional Concentration of Sevoflurane in Inspired Gas
Flow	Flow
Hal	Halothane
I:E	Inspiratory Time : Expiratory Time Ratio
Iso	Isoflurane

---

MAC	Minimum Alveolar Concentration
Manual	Manual Ventilation
MEAN	Mean Pressure
Min Rate	Minimum Breath Rate
MV	Minute Volume
N <sub>2</sub> O	Nitrous Oxide
O <sub>2</sub>	Oxygen
Paw	Airway Pressure
PCV	Pressure Control Ventilation
PEEP	Positive End-expiratory Pressure
Pinsp	Pressure Control Level of Inspiration
Plimit	Pressure Limit Level
PEAK	Peak Pressure
PLAT	Plateau Pressure
PS	Pressure Support
ΔPsupp	Pressure Support Level
Δpapnea	Apnea Pressure
Raw	Resistance
Rate	Breath Rate
Sev	Sevoflurane
SIMV-PC	Synchronized Intermittent Mandatory Ventilation - Pressure Control
SIMV-VC	Synchronized Intermittent Mandatory Ventilation - Volume Control
Tinsp	Time of Inspiration
Tpause	Percentage of Inspiratory Plateau Time in Inspiratory Time
Tslope	Time for the Pressure to Rise to Target Pressure
Vt Exp	Expired Tidal Volume
Vt Insp	Inspired Tidal Volume
Vt	Tidal Volume
VCV	Volume Control Ventilation
VG	Volume Guarantee Control
Volume	Gas Volume



# F Factory Defaults

---

This chapter lists the most important factory default settings which are not user-adjustable. When necessary, you can restore the factory default settings.

## F.1 Main Screen

OBJECT	PARAMETER	FACTORY DEFAULT
Waveforms/ SpirometryTab	/	Waveforms
Spirometry Tab	Loop Type	P-V Loop
	Save Loop	Reference Loop
	Show Reference	Off
	Screen Layout	Spirometry-Waveform split screen
Review Loops menu	Loop Type	Pressure

## F.2 Alarm Menu

PARAMETER	Unit	FACTORY DEFAULT
FiO <sub>2</sub> High Limit	%	100
FiO <sub>2</sub> Low Limit	%	21
EtO <sub>2</sub> High Limit	%	100
EtO <sub>2</sub> Low Limit	%	18
Vt High Limit	mL	1000
Vt Low Limit	mL	5
MV High Limit	L/min	Adu 10 L/min, Ped 6 L/min, Inf 6 L/min
MV Low Limit	L/min	Adu 2 L/min, Ped 1 L/min, Inf 0.2 L/min
Rate High Limit	bpm	40
Rate Low Limit	bpm	2
Paw High Limit	cmH <sub>2</sub> O	Adu 40 cmH <sub>2</sub> O, Ped 40 cmH <sub>2</sub> O, Inf 40 cmH <sub>2</sub> O

Paw Low Limit	cmH <sub>2</sub> O	Adu 4 cmH <sub>2</sub> O, Ped 4 cmH <sub>2</sub> O Inf 4 cmH <sub>2</sub> O
FiCO <sub>2</sub> High	mmHg	4
EtCO <sub>2</sub> High	mmHg	Adu/Ped 50 mmHg Inf 45 mmHg
EtCO <sub>2</sub> Low	mmHg	Adu/Ped 25 mmHg Inf 30 mmHg
EtO <sub>2</sub> High	%	100
EtO <sub>2</sub> Low	%	18

### F.2.1 Agent Alarm limits

PARAMETER	Unit	FACTORY DEFAULT
EtN <sub>2</sub> O High Limit	%	55
EtN <sub>2</sub> O Low Limit	%	0
FiN <sub>2</sub> O High Limit	%	53
FiN <sub>2</sub> O Low Limit	%	0
EtHal High Limit	%	3.0
EtHal Low Limit	%	0.0
FiHal High Limit	%	2.0
FiHal Low Limit	%	0.0
EtEnf High Limit	%	3.0
EtEnf Low Limit	%	0.0
FiEnf High Limit	%	2.0
FiEnf Low Limit	%	0.0
EtIso High Limit	%	3.0
EtIso Low Limit	%	0.0
FiIso High Limit	%	2.0
FiIso Low Limit	%	0.0
EtSev High Limit	%	6.0
EtSev Low Limit	%	0.0
FiSev High Limit	%	5.0
FiSev Low Limit	%	0.0
EtDes High Limit	%	8.0
EtDes Low Limit	%	0.0
FiDes High Limit	%	6.0

FiDes Low Limit	%	0.0
-----------------	---	-----

## F.2.2 Alarm Volume

PARAMETER	FACTORY DEFAULT
Alarms	3
System Alerts	3

## F.3 Main Menu

### F.3.1 General Tab

PARAMETER		FACTORY DEFAULT	
AG Setup tab	Flow Rate	High	
	Operating Mode	Measure	
/	Breathing System	Warmer On	
CO <sub>2</sub> Setup tab	Mainstream	Operating Mode	Measure
		Max Hold	10 s
		Barometric Pressure	760 mmHg
		O <sub>2</sub> Compensation	100%
		AG Compensation	0%
		Balance Gas	Air
	Microstream	Operating Mode	Measure
		Max Hold	20 s
		Humidity Compen.	Off
	Sidestream	Operating Mode	Measure
		Flow Rate	High
		Humidity Compen.	Off
		O <sub>2</sub> Compen.	100%
		N <sub>2</sub> O Compen.	0%

### F.3.2 Display Tab

PARAMETER	FACTORY DEFAULT
Pressure Display	PLAT
Screen Brightness	5
Key Click Volume	3

Plimit Line		On
CO <sub>2</sub> Placement		Top
Waveform Display		Flow
Gas Scales	CO <sub>2</sub> Scale	0-60 mmHg
	O <sub>2</sub> Scale	0-100 %
	N <sub>2</sub> O Scale	0-100 %
	AA Scale	0-9.0 %
	Sev Scale	0-4.0 %
	Iso Scale	0-2.5 %
	Hal Scale	0-2.5 %
	Enf Scale	0-2.5 %

### F.3.3 History Tab

PARAMETER		FACTORY DEFAULT
List Trends	Display Interval	1 min
	Display Group	All
Graphic Trends	Zoom	5 Min
	Display Group	All
Event Log	Filter	All

### F.3.4 System Tab

OBJECT	PARAMETER	FACTORY DEFAULT
/	Change Password	1234
/	Language	English
/	O <sub>2</sub> Cell Monitoring	On
/	Standby Settings	On
/	Clear History	Off
Calibration	External AG Module Calibration	CO <sub>2</sub>
	External AG Module Calibration	N <sub>2</sub> O
	External AG Module Calibration	O <sub>2</sub>
	External AG Module Calibration	Agent
	Internal AG Module	Agent

		Calibration		
		Sidestream CO <sub>2</sub> Module		CO <sub>2</sub>
		Microstream CO <sub>2</sub> Module		CO <sub>2</sub>
Time Settings	Time Zone	+/-		-
		hrs		5
		min		0
	Daylight Savings			Manual
	DST Start	Week of the Month		First
		Day of the Week		Sunday
		Month		Apr
		On/After Day		1
		Time		2:00 AM
	DST End	Week of the Month		Last
		Day of the Week		Sunday
		Month		Oct
		On/After Day		1
		Time		3:00 AM
Network	This Machine	Configure Ethernet	IP Address (Ethernet configuration)	192.168.23.250
			Subnet	255.255.255.0
			Default Gateway	Empty
		Configure Serial	Protocol	None
			Interval	1 Min
			Baud Rate	115200
			Parity	None
			Data Bits	8
			Stop Bits	1
	Network Protocol	HL7		Off
		Interval		1 Min
		Destination IP		192.168.23.200
		Port		1550
	SNTP Protocol	Interval		Off
Primary Server IP		132.163.4.103		
Secondary Server IP		210.72.145.44		
Units		Pressure		cmH <sub>2</sub> O

---

	CO <sub>2</sub>	mmHg
--	-----------------	------

## F.4 Date/Time

PARAMETER	FACTORY DEFAULT
Day	1
Month	1
Year	2009
Hour	00 (24h)
Minute	12 AM (12h)
AM/PM	0
12/24hour	AM
Date format	12
Daylight Saving Time	YYYY-MM-DD

## F.5 Ventilation Modes

OBJECT	FACTORY DEFAULT
Ventilation Mode Tab	VCV

### F.5.1 VCV

PARAMETER	FACTORY DEFAULT
Vt	Adu: 500 mL, Ped: 120 mL, Inf: 20 mL
Rate	Adu: 12 bpm, Ped: 15 bpm, Inf: 20 bpm
I:E	1:2
Tpause	Off
Plimit	Adu: 30 cmH <sub>2</sub> O, Ped: 30 cmH <sub>2</sub> O, Inf: 20 cmH <sub>2</sub> O
PEEP	Off

---

## F.5.2 SIMV-VC

PARAMETER	FACTORY DEFAULT
Vt	Adu: 500 mL, Ped: 120 mL, Inf: 20 mL
Rate	Adu: 12 bpm, Ped: 15 bpm, Inf: 20 bpm
Tinsp	Adu: 1.5 s, Ped: 1.0 s, Inf: 1.0 s
Tpause	Off
Plimit	Adu: 30 cmH <sub>2</sub> O, Ped: 30 cmH <sub>2</sub> O, Inf: 20 cmH <sub>2</sub> O
PEEP	Off
$\Delta$ Psupp	Adu: 15 cmH <sub>2</sub> O, Ped: 5 cmH <sub>2</sub> O, Inf: 5 cmH <sub>2</sub> O
F-Trig	Adu: 3 L/min, Ped: 2 L/min, Inf: 2 L/min
Tslope	0.5 s
Exp%	25 %
Trig Window	25 %

## F.5.3 PCV

PARAMETER	FACTORY DEFAULT
Pinsp	Adu: 15 cmH <sub>2</sub> O, Ped: 10 cmH <sub>2</sub> O, Inf: 10 cmH <sub>2</sub> O
Rate	Adu: 8 bpm, Ped: 15 bpm, Inf: 20 bpm
I:E	1:2
Tslope	0.2 s
PEEP	Off

---

## F.5.4 SIMV-PC

PARAMETER	FACTORY DEFAULT
Pinsp	Adu: 15 cmH <sub>2</sub> O, Ped: 10 cmH <sub>2</sub> O, Inf: 10 cmH <sub>2</sub> O
Rate	Adu: 12 bpm, Ped: 15 bpm, Inf: 20 bpm
Tinsp	Adu: 1.5 s, Ped: 1.0 s, Inf: 1.0 s
$\Delta$ Psupp	Adu: 15 cmH <sub>2</sub> O, Ped: 5 cmH <sub>2</sub> O, Inf: 5 cmH <sub>2</sub> O
PEEP	Off
F-Trig	Adu: 3 L/min, Ped: 2 L/min, Inf: 2 L/min
Tslope	0.5 s
Exp%	25 %
Trig Window	25 %



---

## F.5.5 PS

PARAMETER	FACTORY DEFAULT
Min Rate	Adu: 4 bpm, Ped: 6 bpm, Inf: 12 bpm
PEEP	Off
$\Delta$ Psupp	Adu: 15 cmH <sub>2</sub> O, Ped: 5 cmH <sub>2</sub> O, Inf: 5 cmH <sub>2</sub> O
F-Trig	Adu: 3L/min, Ped: 2L/min, Inf: 2 L/min
Tslope	0.5 s
Apnea I:E	1:2
$\Delta$ Papnea	Adu: 15 cmH <sub>2</sub> O, Ped: 10 cmH <sub>2</sub> O, Inf: 10 cmH <sub>2</sub> O
Exp%	25 %

## F.5.6 Manual

PARAMETER	FACTORY DEFAULT
Alarms	On
Bypass	Off
Monitor	Off
CO <sub>2</sub> Alarms	On

## F.5.7 Standby

OBJECT	PARAMETER	FACTORY DEFAULT
Standby Dialog	Restore default settings	Off

## F.6 Ventilation Parameter Relationships

VENTILATION MODE	PARAMETER	PARAMETER RELATIONSHIP EQUATION(S)
VCV	Rate	$Rate \leq 300 \times \frac{I : E}{1 + I : E}$ $Rate \leq 150 \times \frac{1}{1 + I : E}$ $4 \leq Rate \leq 100$
	Vt	$Vt \leq 1833 \times \frac{60 \times \left( \frac{I : E}{1 + I : E} \right)^* (1 - TP)}{Rate}$ $Vt \geq 20 \times \frac{60 \times \left( \frac{I : E}{1 + I : E} \right) (1 - TP)}{Rate}$ $20 \leq Vt \leq 1500$
	Plimit	$Plimit \geq PEEP + 5$ $10 \leq Plimit \leq 100$
SIMV-VC	Rate	$Rate \leq \frac{60}{T_{insp} + 0.4}$ $4 \leq Rate \leq 100$
	Vt	$20 \times T_{insp} (1 - TP) \leq Vt \leq 1833 \times T_{insp} (1 - TP)$ $20 \leq Vt \leq 1500$
	$\Delta P_{supp}$ (in VCV mode)	$\Delta P_{supp} \leq Plimit - PEEP$ $3 \leq \Delta P_{supp} \leq 60$
	Plimit	$Plimit \geq PEEP + 5$ $Plimit \geq \Delta P_{supp} + PEEP$ $10 \leq Plimit \leq 100$
PCV	Rate	$Rate \leq 300 \times \frac{I : E}{1 + I : E}$ $Rate \leq 150 \times \frac{1}{1 + I : E}$ $4 \leq Rate \leq 100$
	P <sub>insp</sub>	$P_{insp} \geq PEEP + 5$ $5 \leq P_{insp} \leq 60$

SIMV-PC	Rate	$Rate \leq \frac{60}{T_{insp} + 0.4}$ $4 \leq Rate \leq 100$
	$\Delta P_{supp}$	$3 \leq \Delta P_{supp} \leq 60$
	P <sub>insp</sub>	$P_{insp} \geq PEEP+5$ $5 \leq P_{insp} \leq 60$
PS	Min Rate	$0.2 \leq \frac{60}{MinRate} \times \frac{Apnea\ I : E}{1 + Apnea\ I : E} \leq \frac{60}{Min\ Rate} - 0.5$
	Apnea I:E	$\frac{60}{MinRate} \times \frac{Apnea\ I : E}{1 + Apnea\ I : E} \leq 10$

---

**FOR YOUR NOTES**



